

# Loop Cards (VIG-LPC-EN and COMPACT-LPC-EN)

The Loop Cards (VIG-LPC-EN and COMPACT-LPC-EN) are for use in Vigilon and Vigilon Compact panels. The Cards can be identified by the 'SEC-GEN LOOP CARD' marking along the long edge on the component side of the PCB. There should also be a firmware version number label on the PCB, ensure the version requirements are met.

## Selection

How to select a Loop card, MCC/MCB Card and PSU for typical device mix found on sites:

- Choose a selection method.
- Use the information below to find a solution for a site.

Loop card, MCC/MCB and PSU combinations

**1** Post March 2014 <sup>①</sup> and Post June 2017 <sup>②</sup> build of EN Compact Loop card (COMPACT-LPC-EN)

MCB

① ≥V4.52 in a COMPACT-24-N panel  
② ≥V4.54 in a COMPACT-PLUS panel

① ≥V4.48 in a COMPACT-24-N panel  
② ≥V4.49 in a COMPACT-PLUS panel

**2** Post March 2014 build of EN Vigilon Loop card (VIG-LPC-EN)

MCC

① ≥V4.52 in VIG1-24/72 panels  
② ≥V4.54 in VIGPLUS24/72 panels

① ≥V4.48 in VIG1-24/72 panels  
② ≥V4.49 in VIGPLUS24/72 panels

Pre or Post July 2013 Vigilon PSU (VS-PSU-24) or (VS-PSU-72)

**A** or **B** these options require Post Oct 13 PSU

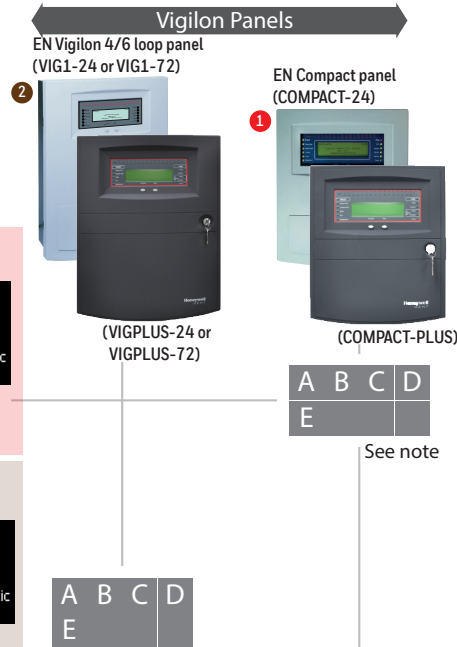

Current scenario	Legacy scenarios				
A	B	C	D	E	F
Up to 2Km loop	Up to 2Km loop	Up to 1Km loop	Up to 1Km loop	Up to 1Km loop	Up to 1km loop
S4 range of products Part 23 compliant	S4 range of products	S4 range of products	34000 range of products	S4 and 34000 of products	34000 and 3400 range of products
S4 with VAD Pt23 compliant + S4 sensor sounders and S4 sensors	S4	S4	S3 mark 1	S4	S4
S3 mark 3 VAD Pt23 compliant	S3 mark 1/2	S3 mark 1/2	S3 mark 1	S3 mark 1/2	S3 mark 1
S4 Interfaces	S4 Interfaces	S4 Interfaces	34000 Interfaces	S4 Interfaces	34000 Interfaces
① ②	① ②	① ②	① ②	① ②	

Typical loop device mix found on sites

VAD is a 'Visual Alarm Device'.

The Loop card (VIG-LPC-EN or COMPACT-LPC-EN) must never be used in a Vigilon panel based System having device mix with 3400 sensors **F**.

Typically the Compact panel based systems use devices shown in site scenarios **A**, **B** and **C**.

A 1Km or 2km loop length is the sum the length of cable used on the main loop and spur circuits off the main loop, on which system devices are connected.

### Selection Method 1

- Select a panel
- Select applicable cards and PSU build
- Determine which site device mix will work, eg: **A** or **B** ---- **D** etc.

For example:

If we have an EN Vigilon 4/6 loop panel (VIG-24) having Cards shown in **2** then it will work with site device mix **A**, **B**, **C**, **D** or **E**.

### Selection Method 2

- Select a site device mix, eg **A** or **B** ---- **D** etc.
- Note the number in circle.
- Match the number in circle with cards and panels.

For example:

If a site has device mix **B** is installed on a 2Km loop and you want to an EN Vigilon Compact panel (COMPACT-24) then Cards shown in **1** must be built into the panel

### Selection Method 3

- Match the number in circle.

For example:

Panel **1** will work with Cards **1** when used in site with Device mix **1**.

## Loop Cards

### Post March 2014 Loop Cards

Post March 2014 Loop Cards are:

- VIG-LPC-EN (for use in Vigilon 4-6 loop panels only)
- COMPACT-LPC-EN (for use in Vigilon Compact panel only)

### Condition of use



**The Loop Cards (VIG-LPC-EN and COMPACT-LPC-EN) must never be fitted as a replacement card in a Vigilon panel where 3400 devices are installed on its loop circuits**

**The Loop Cards (VIG-LPC-EN and COMPACT-LPC-EN) will support some legacy 34000 devices, however will NOT support the 34450 loop powered 4 channel Interface.**

The post March 2014 Loop card (VIG-LPC-EN or COMPACT-LPC-EN) can only be used as a replacement card for Older Build Loop card (VIG-LPC or COMPACT-LPC) where S4 and S3 Mark 1/2 devices or some 34000 devices are installed on a loop circuit, see caution above.

- Up to 2Km loop length is possible with 1.5mm<sup>2</sup> cable with S4 and S3 Mark 1/2 devices installed on a loop circuit. In this case a rough method for calculating the loop load and loop cable length is shown in part 2 of this document. Both parts 1 and 2 of this document can be downloaded by registered user of Gent Expert forum. For precise loop load and battery standby calculation use the 'Battery Standby and Loop load calculator' tool.
- Up to 1Km loop length is possible with 1.5mm<sup>2</sup> cable where 34000 devices or a mix of 34000, S4 and S3 Mark 1/2 devices are installed on a loop circuit. For a precise loop load and battery standby calculation use the 'Battery Standby and Loop load calculator' tool.

### Battery Standby and Loop load calculator tool

The 'Battery standby and loop load calculator' tool can be downloaded from [www.gentexpert.co.uk](http://www.gentexpert.co.uk) website by registered users.

### Vigilon Loop Diagnostic tool

The Vigilon Loop Diagnostic Tool must only be used to diagnose loop circuits driven by Post March 2014 Loop Cards (VIG-LPC-EN or COMPACT-LPC-EN) fitted in a Vigilon panel.



**The Loop Diagnostic Tool cannot be used to diagnose Vigilon panel fitted with Loop Cards (VIG-LPC or COMPACT-LPC).**

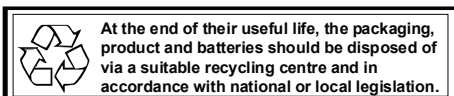

At the end of their useful life, the packaging, product and batteries should be disposed of via a suitable recycling centre and in accordance with national or local legislation.

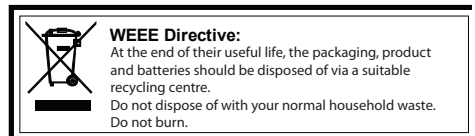

**WEEE Directive:**  
At the end of their useful life, the packaging, product and batteries should be disposed of via a suitable recycling centre.  
Do not dispose of with your normal household waste. Do not burn.

Honeywell Gent reserves the right to revise this publication from time to time and make changes to the content hereof without obligation to notify any person of such revisions of changes.

<b>Honeywell</b> GENT	Hamilton Industrial Park, Waterside Road, Leicester LE5 1TN, UK.		Website: <a href="http://www.gent.co.uk">www.gent.co.uk</a>
	Telephone: +44 (0) 116 246 2000	Tech. Support <a href="http://www.gentexpert.co.uk">www.gentexpert.co.uk</a>	Fax (UK) +44 (0) 116 246 2300

# Loop loading

## (VIG-LPC-EN and COMPACT-LPC-EN)

This document shows how to determine the loop load and loop cable length for a Post March 2014 Loop Card fitted in a Vigilon panel:

- VIG-LPC-EN (for use in Vigilon 4-6 loop panels only)
- COMPACT-LPC-EN (for use in Vigilon Compact panel only)



**A precise battery standby calculation result is obtained using the 'Battery standby and loop load calculator' tool. The tool can be downloaded from [www.gentexpert.co.uk](http://www.gentexpert.co.uk) website, accessible to registered users.**

### Distributed alarm device load

This is where the alarm load is distributed along the entire length of the loop and when using:

- 1.5mm<sup>2</sup> cable, the loop length can be up to 2Km with up to 200 devices and up to 400mA alarm current for standard mode of loop card operation / 800mA alarm load for enhanced mode of loop card operation.
- 2.5mm<sup>2</sup> cable, the loop length can be up to 2.5Km with up to 200 devices and up to 400mA alarm current for standard mode of loop card operation / 800mA alarm load for enhanced mode of loop card operation.

Use table 1 to calculate the loop alarm load.

Always use the 'Battery Standby and loop load calculator tool' to determine loop load and panel battery standby.

### Lumped alarm devices load

If the alarm devices are lumped together on a loop circuit then there is a trade off between the number of alarm devices and loop cable length possible, which must be calculated.

Use the 'Battery Standby and loop load calculator tool' to determine the precise loop length, loop load and panel standby. In the absence of the tool a rough method to determine **loop length and loading only** is shown here. Use table 1 to determine alarm load and respective table 2, 3, 4 or 5 to determine loop length and loop load.

#### What are Lumped and Distributed alarm device loads?

Example of Lumped alarm device load

Where 35% of the alarm devices are lumped together in 1/4 segment (A), (B), (C) or (D) of a loop.

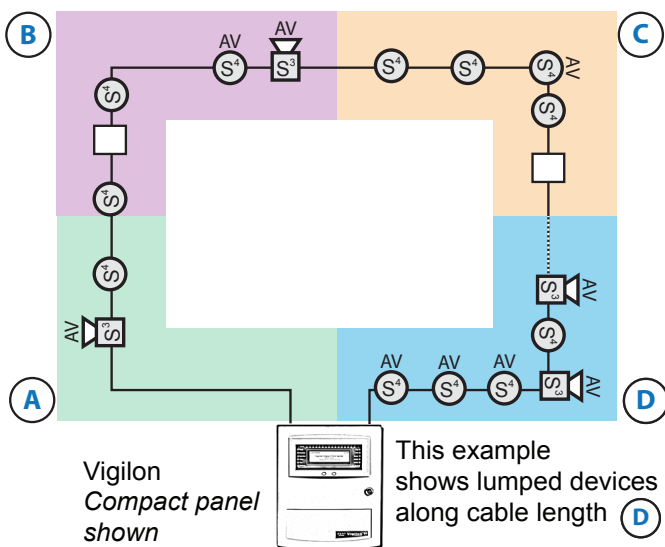

Vigilon Compact panel shown

This example shows lumped devices along cable length (D)

Example of Distributed alarm device load

Distributed alarm devices are evenly spaced along the entire length of the loop cable from end to end.

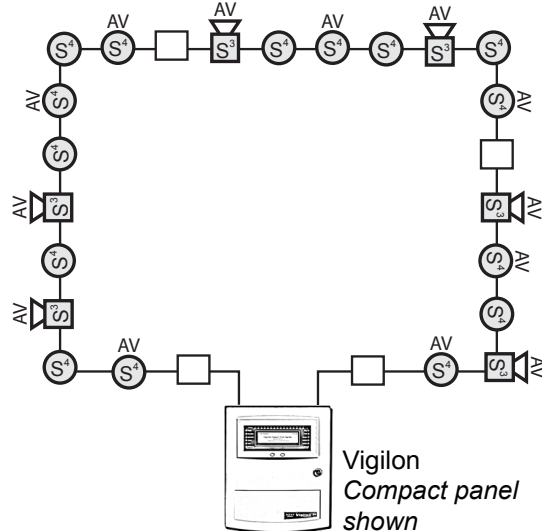

Vigilon Compact panel shown

key: - Audio Visual S4 and S3 devices    - S4 Sensor only devices    - Other system devices



**System with VAD only devices, S4 Sensors and S4 Sensor Sounders is capable of up to 0.8A alarm load.**

**Loop Cable length**

The loop cable length is defined as the sum of the length of cable used on the main loop plus that used on all the spur circuits off the main loop having system devices.

**Loop device load and length calculations for 2Km loop card**

The loop device load can be up to 200 devices and the Loop Cable length can be up to 2Km when using Loop Card (VIG-LPC-EN or COMPACT-LPC-EN), where both device count and cable length are dictated by the number of alarm devices on the loop and how they are positioned, distributed or lumped together.

**Calculations to determine the Total alarm current**

To determine the loop cable length and the number of devices that can be connected on up to 2Km loop the alarm current taken by each device is required. So first calculate the **total alarm current** using **Table 1**. Then use **Table 2** or **3 / 4** or **5** to trade between the loop cable length and device count for lumped alarm device load.

■ To calculate the 'Total Alarm Current':

1. Enter in Table 1 column ① the total number of each device type on a loop.
2. Multiply columns ① x ② to determine the alarm current for each device type.
3. Sum up all device type's alarm current to find out the **total alarm current** **A**.

**Table 1 - Total Alarm Current**



**Note some of the values in the table below may not be exactly the same as those in the Battery Standby and Loop Load Calculator tool. The values are being used here as a rough guide to determine the total alarm current.**

Device part number	Description	VAD POWER	Maximum limit per loop	① No. of Devices on loop	② Alarm current (mA) per device	Alarm current ① x ②
VIG-RPT-72	Repeat panel		4	_____ x	1.20	
VIG-MIM-A3	A3 Zonal/Mimic panel		4	_____ x	1.20	
S4-715	Optical Sensor		200	_____ x	0.20	
S4-720	Heat Sensor		200	_____ x	0.20	
S4-710	Optical Heat Sensor		200	_____ x	0.20	
S4-711	Dual Optical Heat Sensor		200	_____ x	0.20	
S4-770-S	Optical Heat Turbo Sounder		177	_____ x	4.5	
	Optical Heat Non Turbo Sounder		200	_____ x	2	
S4-771-S	Dual Optical Heat Turbo Sounder		177	_____ x	4.5	
	Dual Optical Heat Non Turbo Sounder		200	_____ x	2	
S4-780-S	Heat Turbo Sounder		177	_____ x	4.5	
	Heat Non Turbo Sounder		200	_____ x	2	
S4-711-V-VAD-HPW	Dual Optical Heat Turbo Voice & White VAD	L	76	_____ x	10.5	
		M	50	_____ x	15.8	
		H	39	_____ x	20.25	
	Dual Optical Heat Non Turbo Voice & White VAD	L	100	_____ x	8	
		M	60	_____ x	13.3	
		H	45	_____ x	17.75	
S4-711-V-VAD-HPR	Dual Optical Heat Turbo Voice & Red VAD	L	76	_____ x	10.5	
		M	50	_____ x	15.8	
		H	39	_____ x	20.25	
	Dual Optical Heat non Turbo Voice & Red VAD	L	100	_____ x	8	
		M	60	_____ x	13.3	
		H	45	_____ x	17.75	
S4-711-V	Dual Optical Heat Turbo Voice		177	_____ x	4.5	
	Dual Optical Heat non Turbo Voice		200	_____ x	2	

**Key**

X - Signify colour: R - Red & W - White of product body and strobe light

x - Signify multiply by

~ - A maximum of up to 100 input channels are allowed per loop.

\* - Applicable when sounder is operating in turbo mode or with a bell tone.

# - 8 maximum if outputs are sectored

LV - Low voltage  
MV - Medium voltage

L - Low power Visual Alarm

M - Medium power Visual Alarm

H - High power Visual Alarm

S - Standard power Visual Alarm

## Loop Loading

Device part number	Description	VAD POWER	Maximum limit per loop	① No. of Devices on loop	② Alarm current (mA) per device	Alarm current ① x ②
S4-711-VAD-HPW	Dual Optical Heat & White VAD	L	133	_____ x	6	
		M	70	_____ x	11.3	
		H	50	_____ x	15.75	
S4-711-V-VAD-LPW	Dual Optical Heat Voice & White VAD	S	133	_____ x	6	
S4-711-VAD-HPR	Dual Optical Heat & Red VAD	L	133	_____ x	6	
		M	70	_____ x	11.3	
		H	50	_____ x	15.75	
S4-720-V-VAD-HPW	Heat Turbo Voice & White VAD	L	76	_____ x	10.5	
		M	50	_____ x	15.8	
		H	39	_____ x	20.25	
	Heat Non Turbo Voice & White VAD	L	100	_____ x	8	
		M	60	_____ x	13.3	
		H	45	_____ x	17.75	
S4-720-V-VAD-HPR	Heat Turbo Voice & Red VAD	L	76	_____ x	10.5	
		M	50	_____ x	15.8	
		H	39	_____ x	20.25	
	Heat Non Turbo Voice & Red VAD	L	100	_____ x	8	
		M	60	_____ x	13.3	
		H	45	_____ x	17.75	
S4-911-V-VAD-HPW	Dual Optical Heat CO Turbo Voice & White VAD	L	76	_____ x	10.5	
		M	50	_____ x	15.8	
		H	39	_____ x	20.25	
	Dual Optical Heat CO Non Turbo Voice & White VAD	L	100	_____ x	8	
		M	60	_____ x	13.3	
		H	45	_____ x	17.75	
S4-911-V-VAD-HPR	Dual Optical Heat CO Turbo Voice & Red VAD	L	76	_____ x	10.5	
		M	50	_____ x	15.8	
		H	39	_____ x	20.28	
	Dual Optical Heat CO Non Turbo Voice & Red VAD	L	100	_____ x	8	
		M	60	_____ x	13.3	
		H	45	_____ x	17.75	
S4-911 replaced with S4-901	Dual Optical Heat Sensor & CO		200	_____ x	0.20	
S4-34760	Venturi-Air Duct Kit		200	_____ x	0.20	
S4-34740	Beam sensor pair		16 pair	_____ x	1.00 / pair	
34701	Tee breaker		200	_____ x	0.16	
S4-34800 S4-34805	MCP - glass MCP -resettable		200	_____ x	1.50	
S4-34411 or S4-34415	1 - MV output interface		200	_____ x	0.55	
S4-34440	Mains powered I/F		32 (8 #) ~	_____ x	0.40	
S4-34404 or S4-34401	Mains switching interface		200 (8 #)	_____ x	1.10	
S4-34418	Keyswitch interface		170	_____ x	1.50	
S4-34800 S4-34805	MCP - glass MCP -resettable		200	_____ x	1.50	
S4-34807	Keyswitch - MCP		200	_____ x	1.50	
S4-34410	Switch I/P (inc. zone)		32	_____ x	9.40	
	Switch I/P (exc. zone)		100	_____ x	0.40	
S4-34420	1- I/O interface		170	_____ x	0.43	
S4-34450	1-4 I/O (inc. zone)		32	_____ x	10.99	
	1-4 I/O (exc. zone)		32	_____ x	1.99	

continued on next page....

	Device part number	Description	VAD POWER	Maximum limit per loop	① No. of Devices on loop	② Alarm current (mA) per device	Alarm current ① x ②
* Selection of any one of these devices reverts Loop card to Standard Mode of operation.	S2IP-ST-XR	Strobe Red		100	_____ x	4.00	
	S2IP-ST-XW	Strobe White		40	_____ x	10.0	
	S3-SN-X	Sounder		200	_____ x	2.00	
	S3IP-SN-X S2IP-SN-X inc. suffix -V2			88*	_____ x	4.50*	
	S3-VP-X S3IP-VP-X	Sounder with Speech		55	_____ x	7.00	
	S3-VP-ST-XR S3IP-VP-ST-XR	Sounder Speech with red strobe		40	_____ x	10.0	
	S3-SN-ST-XR S3IP-SN-ST-XR inc. suffix -V2	Sounder with red Strobe		65	_____ x	6.10	
				45*	_____ x	8.6*	
	S3IP-SN-ST-XW inc. suffix -V2	Sounder with white Strobe		35	_____ x	11.4	
				28*	_____ x	13.9*	
	S4-780	Heat Sensor, Sounder & Speech		120	_____ x	3.30	
				65*	_____ x	6.10	
	S4-720-ST-VO	Heat Sensor, Speech & Strobe		55	_____ x	7.00	
				40*	_____ x	10.0	
	S4-770	Optical Heat Sensor & Sounder		150	_____ x	2.60	
				75*	_____ x	5.30	
S4-711-VO	Dual Optical + Heat Sensor & Speech		120	_____ x	3.30		
			65*	_____ x	6.10		
S4-711-ST	Dual Optical Heat Sensor & Strobe		100	_____ x	4.00		
S4-771	Dual Optical Heat Sensor & Sounder		150	_____ x	2.60		
			75*	_____ x	5.30		
S4-711-ST-VO	Dual Optical Heat Sensor, Speech & Strobe		55	_____ x	7.00		
			40*	_____ x	10.0		
S4-911-ST-VO	Dual Optical Heat Sensor & CO Strobe Sounder Speech		55	_____ x	7.00		
			40	_____ x	10.0		
<b>A</b> Total Alarm Current							

**Distributed Alarm load**

Ensure the Total Alarm Current value calculated does not exceed the maximum total alarm current value shown below to achieve 2Km loop length when using 1.5mm<sup>2</sup> cable or 2.5Km loop length when using 2.5mm<sup>2</sup> cable, in both cases a maximum of 200 devices are allowed on a loop:

- ❑ Maximum total alarm current of 400mA (standard mode) with non VAD and can have VAD devices too on the loop
- ❑ Maximum total alarm current of 800mA (enhanced mode) with VAD only devices on the loop

**Lumped Alarm Load**

The Total Alarm Current value calculated above which must not exceed 400mA for Standard mode / 800mA for Enhanced mode and the respective tables on the following pages must be used to determine allowable loop devices and loop cable length possible for lumped alarm load.

Use the rounded up **total alarm current** value from **Table 1** in **Table 2 or 3 / 4 or 5** to trade between the loop cable length **B** and device count **C** for lumped alarm device load, see sections:

- ❑ ‘Loop length and quantities for Standard mode with non VAD devices’ (400mA maximum alarm current).
- ❑ and ‘Loop length and quantities for Enhance mode with VAD only devices’ (800mA maximum alarm current)

## Loop Loading

### Loop length and quantities for Standard mode with non VAD devices

Use either Table 2 or Table 3 to determine the maximum number of devices on a loop and loop cable length possible for lumped alarm load. The examples 1 and 2 below show how to use the tables to determine loading and loop cable length.

**Table 2 Lumped load using 1.5mm<sup>2</sup> loop cable**

Assuming S-Quad with older sounder including strobe and S-Cube Mark 1/2 devices, ie non compliant Part 23 devices.

A Total Alarm Current	B Loop cable length in Km including spurs using 1.5mm <sup>2</sup> cable													
	0.7	0.8	0.9	1.0	1.1	1.2	1.3	1.4	1.5	1.6	1.7	1.8	1.9	2.0
225 mA														
250 mA												190	160	130
275 mA										190	150	130	100	70
300 mA									170	130	100	70	n/a	n/a
325 mA							180	150	120	90	n/a	n/a	n/a	n/a
350 mA						170	140	110	70	n/a	n/a	n/a	n/a	n/a
375 mA					160	130	100	70	n/a	n/a	n/a	n/a	n/a	n/a
400 mA				170	140	110	70	n/a	n/a	n/a	n/a	n/a	n/a	n/a

**C** Maximum allowed devices of any type on a loop for a Lumped alarm load only.

□ blank cell = 200 devices  
n/a = not applicable (condition not allowed)

**Table 3 Lumped load using 2.5mm<sup>2</sup> loop cable**

Assuming S-Quad with sounder including strobe and S-Cube Mk 1/2 devices, ie non compliant Part 23 devices.

A Total Alarm Current	B Loop cable length in Km including spurs using 2.5mm <sup>2</sup> cable																				
	0.7	0.8	0.9	1.0	1.1	1.2	1.3	1.4	1.5	1.6	1.7	1.8	1.9	2.0	2.1	2.2	2.3	2.4	2.5		
200 mA																					
275 mA																					
300 mA																	190	170	150		
325 mA															180	170	150	120	100		
350 mA														180	150	120	110	100	80	60	
375 mA													190	170	150	120	100	80	60	n/a	n/a
400 mA										190	170	150	130	110	90	70	n/a	n/a	n/a	n/a	

**C** Maximum allowed devices of any type on a loop for a Lumped alarm load only.

□ blank cell = 200 devices  
n/a = not applicable (condition not allowed)

#### Example 1

##### Devices allowed on a known loop cable length for Lumped alarm load

If the loop cable length is known then you can determine the maximum number of devices that can be connected to a loop where there is lumped alarm devices.

- First calculate the **total alarm current** value **A**, use **Table 1**.
- Use the calculated **total alarm current** **A** and the known loop cable length **B** to look up in **Table 2** or **3** the maximum number of devices **C** that can be connected to the loop.

For example if the **total alarm current** **A** is 350mA when using 1.5mm<sup>2</sup> loop cable that is **B** 1.5Km in length, then **Table 2** tells you for **lumped alarm devices** the maximum number of devices allowed on the loop must be limited to **C** 70 devices.

#### Example 2

##### Loop cable length allowed for known Lumped alarm device load

If the number of devices on a loop is known then you can determine the maximum cable length that can be used on the loop circuit.

- First calculate the **total alarm current** value **A**, use **Table 1**.
- Use the **total alarm current** **A** and the known number of devices on the loop to look up in **Table 2** or **3** and work out the maximum length of loop cable allowed **B** for the connection lumped alarm devices.

For example if the **total alarm current** **A** is 225mA and if 200 devices **C** are required on the loop, then **Table 2** tells you the maximum loop cable length **B** can be 2Km for lumped alarm load, when using 1.5mm<sup>2</sup> loop cable. However **Table 2** tells you if 2.5mm<sup>2</sup> loop cable is used then the cable length can be up to 2.5Km.

## Loop length and quantities for Enhance mode with VAD only devices

Use either Table 4 or Table 5 to determine the maximum number of devices on a loop and loop cable length possible for lumped alarm load. The examples 1 and 2 below show how to use the tables to determine loading and loop cable length.

**Table 4 Lumped load using 1.5mm<sup>2</sup> loop cable**

Assuming VAD only devices on loop, ie S-Quad with VAD which are compliant to EN54 Part 23.

A Total Alarm Current	Loop cable length in Km including spurs using 1.5mm <sup>2</sup> cable B													
	0.7	0.8	0.9	1.0	1.1	1.2	1.3	1.4	1.5	1.6	1.7	1.8	1.9	2.0
100 mA														
200 mA														
300 mA														
400 mA												190	180	170
500 mA							180	160	140	130	110	90	80	
600 mA			190	170	150	140	120	100	80	60	n/a	n/a	n/a	
700 mA	190	170	150	120	110	90	70	n/a	n/a	n/a	n/a	n/a	n/a	
800 mA	180	150	130	110	90	n/a	n/a	n/a	n/a	n/a	n/a	n/a	n/a	

**C** Maximum allowed devices of any type on a loop for a Lumped alarm load only

□ blank cell = 200 devices  
n/a = not applicable (condition not allowed)

**Table 5 Lumped load using 2.5mm<sup>2</sup> loop cable**

Assuming VAD only devices on loop, ie S-Quad with VAD which are compliant to EN54 Part 23.

A Total Alarm Current	Loop cable length in Km including spurs using 2.5mm <sup>2</sup> cable B																			
	0.7	0.8	0.9	1.0	1.1	1.2	1.3	1.4	1.5	1.6	1.7	1.8	1.9	2.0	2.1	2.2	2.3	2.4	2.5	
200 mA																				
300 mA																				
400 mA																				
500 mA														190	170	160	150	140		
600 mA									190	180	170	150	140	100	90	80	60	n/a		
700 mA						190	170	160	150	130	120	110	100	60	n/a	n/a	n/a	n/a		
800 mA			190	180	160	150	130	120	110	100	80	70	60	n/a	n/a	n/a	n/a	n/a		

**C** Maximum allowed devices of any type on a loop for a Lumped alarm load only

□ blank cell = 200 devices  
n/a = not applicable (condition not allowed)

### Example 1

#### Devices allowed on a known loop cable length for Lumped alarm load

If the loop cable length is known then you can determine the maximum number of devices that can be connected to a loop where there is lumped alarm devices.

- First calculate the **total alarm current** value **A**, use **Table 1**.
- Use the calculated **total alarm current** **A** and the known loop cable length **B** to look up in **Table 4** or **5** the maximum number of devices **C** that can be connected to the loop.

For example if the **total alarm current** **A** is 600mA when using 1.5mm<sup>2</sup> loop cable that is **B** 1.6Km in length, then **Table 4** tells you for **lumped alarm devices** the maximum number of devices allowed on the loop must be limited to **C** 60 devices.

### Example 2

#### Loop cable length allowed for known Lumped alarm device load

If the number of devices on a loop is known then you can determine the maximum cable length that can be used on the loop circuit.

- First calculate the **total alarm current** value **A**, use **Table 1**.
- Use the **total alarm current** **A** and the known number of devices on the loop to look up in **Table 4** or **5** and work out the maximum length of loop cable allowed **B** for the connection lumped alarm devices.

For example if the **total alarm current** **A** is 300mA and if 200 devices **C** are required on the loop, then **Table 4** tells you the maximum loop cable length **B** can be 2Km for lumped alarm load, when using 1.5mm<sup>2</sup> loop cable. However **Table 5** tells you if 2.5mm<sup>2</sup> loop cable is used then the cable length can be up to 2.5Km.

## Loop Loading

### Panel messages associated with Loop cards V4.48 and possible actions

Message..	Indications given..	associated with..	meaning..	possible action
Loop n: High resistance on negative line	FAULT LED - On Buzzer - On	LPC (2Km Loop Processor Card)	High resistance on 0v lines.	Use the Loop Diagnostic Tool to diagnose the cause of high resistance on the negative line and rectify it.
Loop n: High resistance	FAULT LED - On Buzzer - On	LPC (2Km Loop Processor Card)	High resistance on both lines.	Use the Loop Diagnostic Tool to diagnose the cause of high resistance on the loop and rectify it.
Earth Fault at Card n Loop n: 0v resistance is xxR, L is y Loop n: Earth is aaa, bbb (99)		LPC (2Km Loop Processor Card)	There is an earth fault present before allocation. Note: An Earth fault post allocation is indicated as Earth fault.	Use the Loop Diagnostic Tool to diagnose the earth fault condition and rectify it.

### Technical Data - Loop Cards (VIG-LPC-EN and COMPACT-LPC-EN)

Dimensions	VIG-LPC-EN 130mm x 100mm x 15mm COMPACT-LPC-EN 120mm x 100mm x 15mm
Weight	74g approximately
Devices	200 device / loop circuit
Voltage and Current	46.4V in alarm @ 0.8A maximum load #
Terminations and cables	The wiring terminals are located on the Iconic panel Baseboard, each can accept up to 2.5mm <sup>2</sup> cable  Cables: Use only the EMC compliant 2-core fire cables recommended in the panel Installation manual.
Loop cable length can be:	up to 1.5Km with 1.5mm <sup>2</sup> cable # up to 2.5Km with 2.5mm <sup>2</sup> cable #
Operating temperature	0°C to +45°C
Storage temperature	-10°C to +55°C
Relative humidity (non condensing)	up to 90%

# - refer to battery standby and loop load calculator to determine the loop cable length.

# Loop Loading

## Difference between new and old Vigilon 4/6 loop panel hardware

To enable the new loop card to supply the full alarm load in a system having Vigilon 4/6 loop panel we need the new power supply, backplane and loop card. The following photos show where to look to identify old and new parts.

Post July 2013 build of Vigilon Backplane

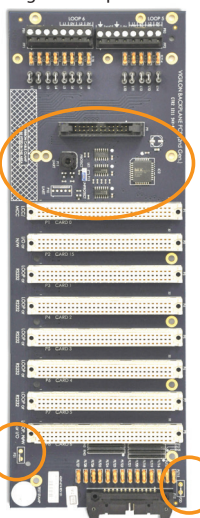

Older build of Vigilon Backplane



(VS-PSU-24) or (VS-PSU-72)  
Post July 2013 build of Vigilon PSU



Older build of Vigilon PSU



(VIG-LPC-EN)  
Post March 2014 build of Vigilon LPC

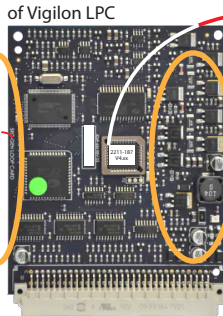

Labels with Software version and part numbers

SEC-GEN LOOP CARD

(VIG-LPC)  
Older build of build of Vigilon LPC

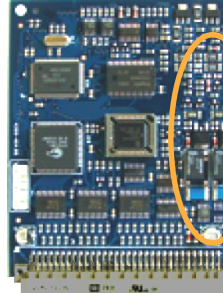

**How to check which Loop Processor Card is fitted in the Vigilon panel**

- Find the loop card status under the Info menu.
- Observe if the loop card is (1) or (2).

```

[Info]
  [Status]
    [Card]
      LPC can be Card 1 to 6 {Params 0-15} [E] [C] [Q]
  
```

```

Card 1: Fault 0: Disable 0: Warning 0
Loop card (2) Version 4.48 23\9\2013
Loop Started, loop Complete
z Devices: 0 Feebreakers
0V resistance is xxR, L is y
  
```

(1) VIG-LPC build (Old loop card)  
(2) VIG-LPC-EN build (New loop card)

Older loop card will not display resistance and L values

 At the end of their useful life, the packaging, product and batteries should be disposed of via a suitable recycling centre and in accordance with national or local legislation.

 **WEEE Directive:**  
At the end of their useful life, the packaging, product and batteries should be disposed of via a suitable recycling centre.  
Do not dispose of with your normal household waste. Do not burn.

Honeywell Gent reserves the right to revise this publication from time to time and make changes to the content hereof without obligation to notify any person of such revisions of changes.

<b>Honeywell</b> GENT	Hamilton Industrial Park, Waterside Road, Leicester LE5 1TN, UK.	Website: <a href="http://www.gent.co.uk">www.gent.co.uk</a>
	Telephone: +44 (0) 116 246 2000	Tech. Support <a href="http://www.gentexpert.co.uk">www.gentexpert.co.uk</a>