

S-Cubed Mark 3 - Type A Data and Installation



These instructions cover the installation of wall mounted S-Cubed Mark 3 Type A devices. They are suitable for use in compatible GENT Vigilon fire alarm systems.

Sounder & Voice Sounder Type A (IP21)	
S3-S-R	S3 Sounder/Red Body
S3-V-R	S3 Voice Sounder/Red Body
S3-S-W	S3 Sounder/White Body
S3-V-W	S3 Voice Sounder/White Body
Visual Alarm (VAD) Type A (IP21)	
S3-VAD-HPW-R	S3 VAD/High Perf. White VAD/Red body
S3-VAD-HPR-R	S3 High Perf. Red VAD/Red Body
Sounder and Visual Alarm (VAD) Type A (IP21)	
S3-S-VAD-HPW-R	S3 Sounder/High Perf. White VAD/Red Body
S3-S-VAD-HPR-R	S3 Sounder/High Perf. Red VAD/Red Body
S3-S-VAD-HPW-W	S3 Sounder/High Perf. White VAD/White Body
S3-S-VAD-HPR-W	S3 Sounder/High Perf. Red VAD/White Body
S3-S-VAD-LPR-R	S3 Sounder/Standard Perf. Red VAD/Red Body
S3-S-VAD-LPW-R	S3 Sounder/Standard Perf. White VAD/Red Body
Voice Sounder and Visual Alarm (VAD) Type A (IP21)	
S3-V-VAD-HPW-R	S3 Voice Sounder/High Perf. White VAD/Red Body
S3-V-VAD-HPR-R	S3 Voice Sounder/High Perf. Red VAD/Red Body
Shallow Base options for Type A (IP21) products	
S3-BASE-SR	Shallow Base / Red Body (5 pack)
S3-BASE-SW	Shallow Base / White Body (5 pack)

The S-Cubed product range incorporates innovative design features protected by Patents GB2388994, GB2388995 and GB2388916.

The S-Cubed Mark 3 devices are configured during commissioning to operate to site specific requirement. These devices are designed for internal applications and should be mounted on the internal walls of a building.

Do's

- Follow the recommendations that relate to alarm sounders, see Section 16 of BS5839 : Part 1 : 2013
- Locate Visual Alarm Devices in accordance with Loss Prevention Council Code of Practice CoP 0001. <http://www.redbooklive.com/lps.jsp>
- Check and ensure the S-Cubed Mark 3 devices are compatible with the system control panel software, see technical data
- Use correct methods to open and close a device
- Mount the device with the marking 'TOP' uppermost, to allow Visual Alarm and the remote control operation
- Ensure the PCB cover is in place over the PCB to protect external cables and components on PCB
- Ensure the earth continuity strap is fitted in the optional deep base
- Install a Visual Alarm horizontally using a levelling method or tool
- Clean any dust off the lens of a Visual Alarm using a lint free cloth

Don'ts

- Don't scratch the lens on a Visual Alarm
- Don't flush mount the Base
- Don't have excessive incoming cable slack
- Don't locate a device such that the audible and visual outputs are obstructed
- Don't mount the device above obstructions, such as shelves that prevent IR remote control operation
- Don't paint the device enclosure
- Don't mount a 'Type A' device onto an external wall surface.

Installation

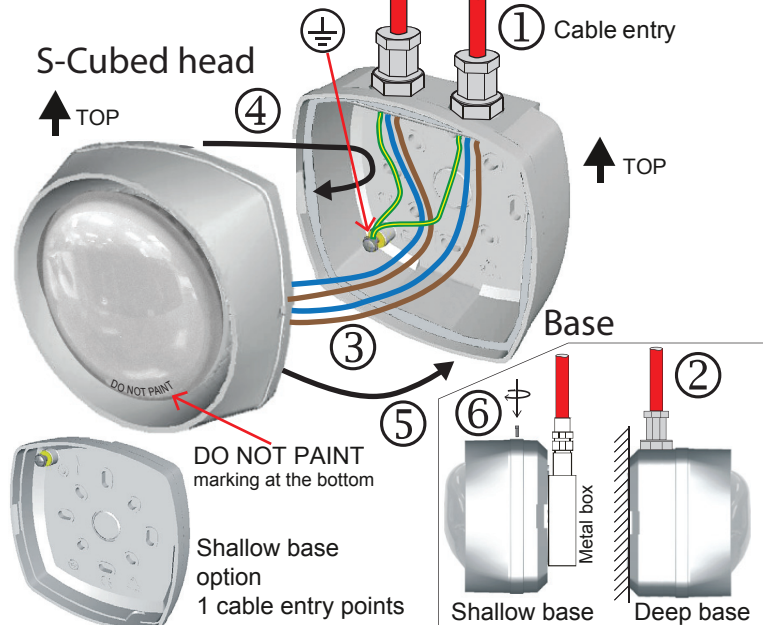

- Knock out or drill # the cable entry points ① on the Base and route the cable through the centre hole. **Where knockout is not possible use the centre indent to drill out the required entry points..**
- The Base must be mounted onto a flat wall or metal box at least 10 cm below ceiling to allow access to the locking screw on shallow base only.
- Route the cables through the cable entry hole and then secure the Base to the Wall / Metal box ② whilst ensuring the Top of the Base is in correct orientation with arrow pointing upwards.
- Ensure there is no more than 10cm (4") tail wire length ③.

Wiring

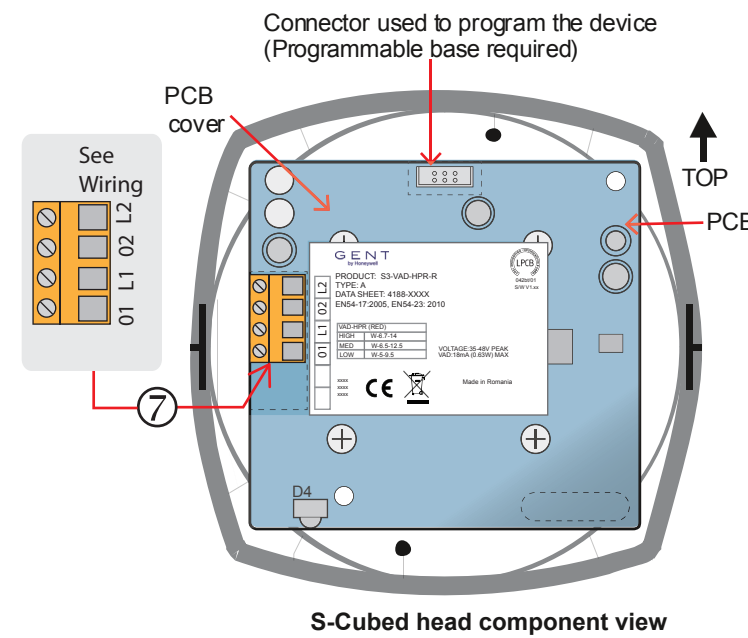
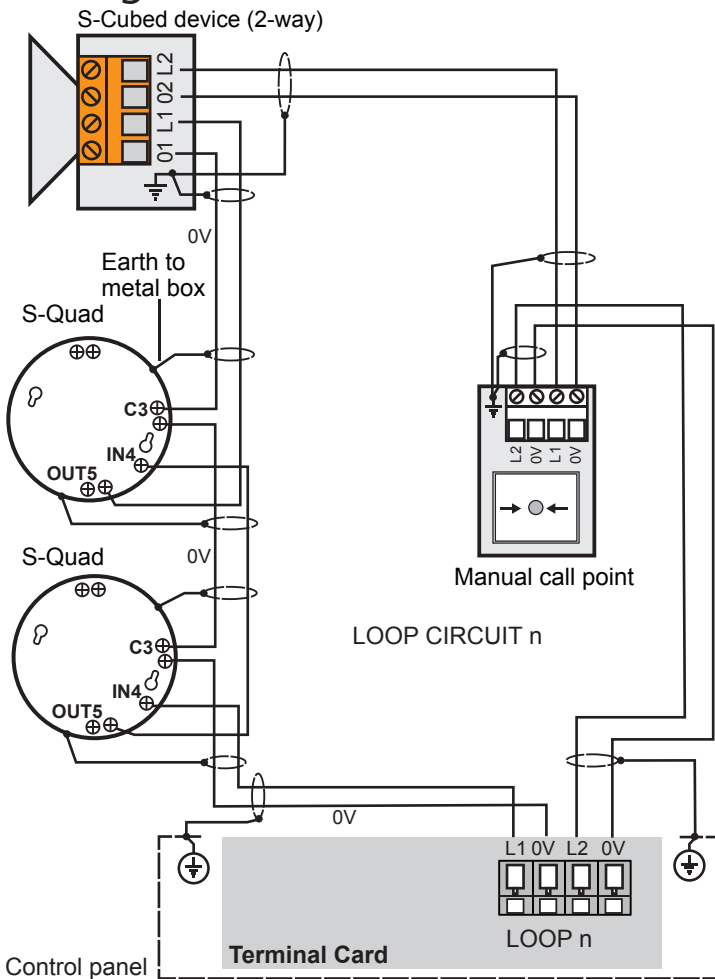

- Ensure the PCB cover is in place over the PCB. Connect the wires to the terminal block ⑦, see also Wiring.
- Align the S-Cubed head with the left clip on the Base ④ and then close the head against the Base until a click is heard ⑤. Ensure the two parts are locked together. For the shallow base use a self tapping screw supplied to secure the assemblies ⑥.

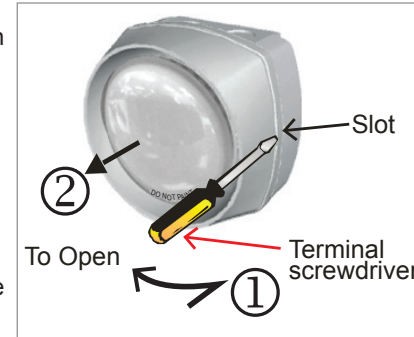

Technical data

Standards

Sounder - EN54-3 : 2001, A1:2002, A2:2006
Visual Alarm Device (VAD) - EN54-23 : 2010
Short-circuit isolator - EN54-17 : 2005

Sound level - for Sounder only
103dB(A) +/-3dB 90° at 1m

VAD flash rate
pulsed output every 2s

Weight of S-Cubed VAD + base
293g deep base
271g with optional shallow base

Compatibility
see section headed Compatibility

Ambient operating temperature
-10°C to +50°C

Relative Humidity
95% non condensing
(+5°C to +45°C)

Storage Temperature
-20°C to +70°C

Operating voltage
35V - 48V

IP Ratings IP 21

Material - body and lens Polycarbonate
base - ABS

Colour
Red body RAL 3020
White body RAL 9010

Flammability V2 Rated

IR remote - volume control
Operating range up to 3m

EN54-17 data - short circuit isolator
Vmax 48V ICmax 0.8A
Vnom 40V ISmax 1.25A
Vmin 24V ILmax 50µA
VSOmax 16V ZCmax 0.13Ω
VSOmin 8V

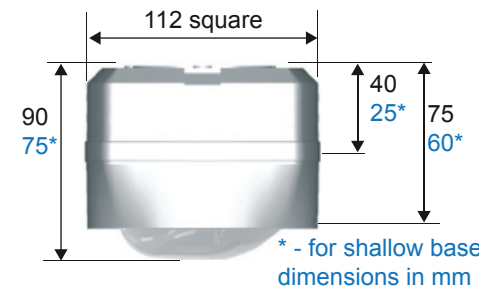

Tones and Messages

Tones

Signal 1* Intermittent tone 970Hz ±10% @ 1Hz
Signal 2* Alternating tone 730Hz ±10% / 970Hz ±10% @ 2Hz
Signal 3* High Tone (Continuous 970Hz ±10%)
The Signals marked with an * are LPCB approved.

Speech messages

Message 1

Bell tone

Message 2 (with Signal 3)

Attention please this is an emergency please leave the building by the nearest available exit. (female voice)

Message 3 # (with Signal 1)

An incident has been reported in this building please await further instructions. (female voice)

Message 4

This is a test message no action is required. (female voice)

Message 5 # (with Signal 2)

This is a fire alarm please leave the building immediately by the nearest available exit. (male voice)

Approved to EN54-3 Annex C.

Message and attention Tone

Programmable period normally set at 10 seconds can be configured up to 30 seconds. The default period is 10 seconds. This may be altered (using the commissioning tool) to suit custom messages or use of non standard tones

Flash memory can hold up to 20 seconds of audio and bell tone.

Volume control

Wall S-Cubed

The volume of a Sounder S-Cubed can be adjusted by the Commissioning tool or by a remote control with panel in Test mode. Save the new volume at the panel after adjustment.

The sound levels in the areas should be tested in accordance with the British Standard requirements and to meet the site specific needs as agreed with the customer.

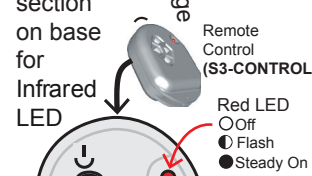

Trouble shooting
If the remote control fails to operate in close proximity to the thinned section of the S-Cubed device, then a possible cause may be the battery. Replace the battery.

- Perform a short press on the Power button to turn On the remote control. The Red LED will flash x1 every 2 seconds
- Press the f function button to toggle between: **Volume** function and note the Red LED flashes x1 every 2 seconds
Tone/Speech message function and note the Red LED flashes x2 every 2 seconds
- Press the + or - to increase or decrease **volume** or to select next or previous **tone/Speech**
Note: The light on the S-Cubed unit if fitted will flash rapidly when the volume is being adjusted using the remote control.
- Press and hold the Power button to save the settings. The Red LED will remain On whilst the button is held pressed. The data is saved to the unit when the tone/speech on the S-Cubed stops briefly. Release the button on the remote control and the Red LED will switch Off.

Visual Alarm Coverage data

A wall mounted Visual Alarm Device (VAD) covers a cuboid volume with a minimum effective illuminance of 0.4 Lux.

The coverage volume is stated as:

W-x-y

- where 'W' is the wall mounted category
- 'X' is the maximum mounting height in metres (minimum 2.4m)
- 'y' is the maximum length and width of cubic volume in metres.

This diagram shows how to relate to the cuboid when the device is mounted at height 'X'.

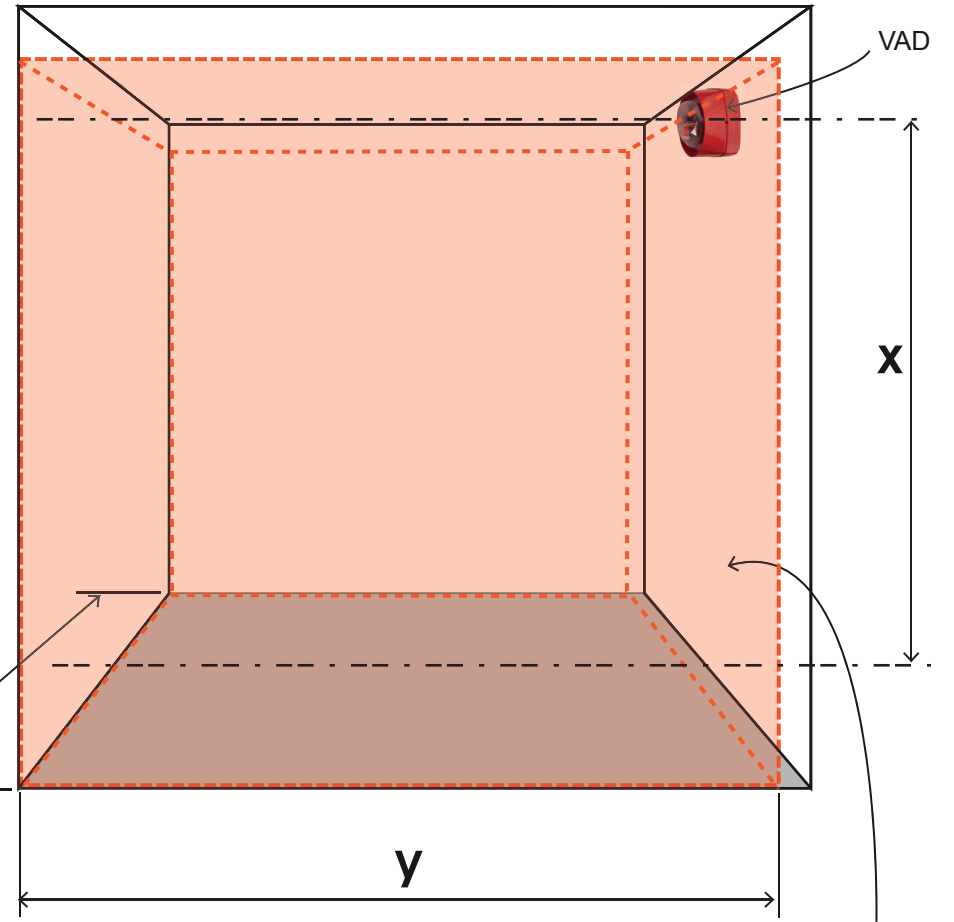

Cuboid surface with minimum illumination of 0.4Lm/m²

Performance data for S-Cubed Mark 3 Type A devices

Table 1 Shows the worst case performance data for S-Cubed White VAD (high perform. -HPW & standard perform. -LPW) and S-Cubed Red VAD (high perform. -HPR & standard perform. -LPR)

	Power setting	Maximum loop current and power for the VAD only	Maximum loop current and power for the sounder (minimum voltage)	Maximum total loop current and power for VAD and sounder	EN54-23 rating & coverage volume in cubic metres			
					WHITE VAD (high performance HPW)		RED VAD (high performance HPR)	
High Performance	High	18mA (630mW)	Turbo = 5mA (175mW)	23mA (805mW)	W - 5 - 12.5	781	W - 6.7 - 14	1313
			Non Turbo = 3mA (105mW)	21mA (735mW)				
	Medium	14mA (490mW)	Turbo = 5mA (175mW)	19mA (665mW)	W - 4.5 - 11.3	574	W - 6.5 - 12.5	1015
			Non Turbo = 3mA (105mW)	17mA (595mW)				
	Low	8mA (280mW)	Turbo = 5mA (175mW)	13mA (455mW)	W - 3 - 8.5	216	W - 5 - 9.5	451
			Non Turbo = 3mA (105mW)	11mA (385mW)				
Standard Performance		8mA (280mW)	Turbo = 5mA (175mW)	13mA (455mW)	W - 3 - 8.5	216	W - 3 - 8.5	216

CoP 0001 Coverage distance multiplication factors

The table below shows how the EN54-23 coverage specification will vary with the ambient light level and if the VAD can be viewed directly or indirectly i.e. if it relies on reflections to be viewed.

It is however advisable to site the VAD so that direct viewing is possible to maximize the VAD coverage.

Table 2

Ambient light level (Lux)	Wall mount direct viewing	Wall mount indirect viewing
<100	5.2	1.8
100-200	4.4	1.7
200-300	3.2	1.4
300-400	2.3	1.2
400-500	1.8	1.0
500-600	1.3	0.9
600-700	1.0	0.7*
700-800	0.7	0.6*

* Where ambient light levels may, at any time, exceed 600 lux, direct viewing is preferred.

Select the correction factor from Table 2 and multiply it with the cuboid dimensions. The coverage of the VAD will increase or decrease depending on the light level and line of sight.

TIP To survey and determine the ambient light levels a LUX meter that complies with BS667 should be used.

Symbols on Product

- Protective Earth connection terminal.
- The WEEE symbol. It indicates this product is to be recycled and not thrown away.
- The CE compliance logo. This product is in conformity with the relevant European Union harmonisation legislation.

RoHS The RoHS compliance logo. The RoHS directive restricts the use of certain hazardous substances commonly used in electronic and electronic equipment.

CE
2811

Gent by Honeywell (Novar Systems Limited)
Manufactured by: Honeywell Life Safety Systems,
Leicester, LE5 1TN, United Kingdom

DoP 083-CPR-2014 083-CPR-2014 084-CPR-2014 084-CPR-2014 085-CPR-2014 086-CPR-2014 087-CPR-2014 088-CPR-2014 087-CPR-2014 088-CPR-2014 089-CPR-2014 090-CPR-2014 105-CPR-2014 110-CPR-2014	Product No. S3-S-R S3-S-W S3-V-R S3-V-W S3-VAD-HPW-R S3-VAD-HPR-R S3-S-VAD-HPW-R S3-S-VAD-HPR-R S3-S-VAD-HPW-W S3-S-VAD-HPR-W S3-V-VAD-HPW-R S3-V-VAD-HPR-R S3-S-VAD-LPW-R S3-S-VAD-LPR-R
---	---

EN54-3:2001, A1:2002, A2:2006, EN54-17:2005, EN54-23:2010

S3-S-R (EN54-3,17) S3-S-W (EN54-3,17) S3-V-R (EN54-3,17) S3-V-W (EN54-3,17) S3-VAD-HPW-R (EN54-17,23) S3-VAD-HPR-R (EN54-17,23)	S3-S-VAD-HPW-R (EN54-3,17,23) S3-S-VAD-HPR-R (EN54-3,17,23) S3-S-VAD-HPW-W (EN54-3,17,23) S3-S-VAD-HPR-W (EN54-3,17,23) S3-V-VAD-HPW-R (EN54-3,17,23) S3-V-VAD-HPR-R (EN54-3,17,23) S3-S-VAD-LPW-R (EN54-3,17,23) S3-S-VAD-LPR-R (EN54-3,17,23)
--	--

Intended for use in fire detection and fire alarm systems
in and around buildings

Refer to DoP 083-CPR-2014 to DoP 090-CPR-2014,
DoP 105-CPR-2014 and DoP110-CPR-2014 for level or
class of performance declared, for details see website www.gent.co.uk

LPCB

042bj
042bs
042bt

For model reference associated with LPCB certificate see list below

Product No.	LPCB No.
S3-S-R	042bj/21
S3-S-W	042bj/23
S3-V-R	042bj/22
S3-V-W	042bj/24
S3-VAD-HPW-R	042bs/02
S3-VAD-HPR-R	042bt/01
S3-S-VAD-HPW-R	042bs/03
S3-S-VAD-HPR-R	042bs/01
S3-S-VAD-HPW-W	042bs/06
S3-S-VAD-HPR-W	042bs/02
S3-V-VAD-HPW-R	042bs/04
S3-V-VAD-HPR-R	042bs/05
S3-S-VAD-LPW-R	042bs/12
S3-S-VAD-LPR-R	042bs/11

Compatibility

Vigilon

The S-Cubed Mark 3 devices with VAD can be used in a Vigilon panel based system providing the software versions stated below are met.

All VAD devices can either operate in 'Compliant mode' to meet the requirements of EN54 Part 23 or as Visual Indicator Device (VID) that operate in 'Non Compliant mode', meaning they DO NOT meet EN54 Part 23.

i The system design may incorporate S-Cubed with VAD and S-Quad with VAD to achieve visual alarm coverage.

≥ means equal to or greater than	EN Vigilon Panels				
	Vigilon 4 loop	Vigilon Compact	Vigilon Compact VA	Vigilon 4-6 loop	All panels
Cards	MCC	MCB	MCB	MCC	LPC
All S-Cubed Mark 3 devices (VADs in 'Compliant mode')	≥ V4.52	≥ V4.52	-	≥ V4.52	≥ V4.48
# All S-Cubed Mark 3 devices (VADs operate as VID in 'Non compliant mode')	≥ V4.37	≥ V4.37	≥ V4.37	≥ V4.37	≥ V4.30

A Vigilon System is configured using Vigilon Commissioning Tool ≥ V1.30.

VAD data shown in Table 1 are not applicable with the panel software stated below.

≥ means equal to or greater than	BS Vigilon 4-loop Panel	
Cards	MCC	LPC
# All S-Cubed Mark 3 with VAD devices (VADs operate as VID in 'Non compliant mode')	≥ V3.90	≥ V3.90

A Vigilon System is configured with Vigilon Commissioning Tool V1.30.

Nano

Note: All S-Cubed with VAD can be installed in a GENT Nano fire alarm system with panel card software stated below. The VADs will only operate at a Low Power setting to meet EN54 Part 23.

≥ means equal to or greater than	Nano Panel	
Cards	MCB	LP
All S-Cubed Mark 3 with VAD devices	≥ V3.12	≥ V1.08

Nano system is configured using Nano Commissioning Tool ≥ V3.0.

i It is recommended that the 'Battery Standby and Loop load Calculator' is used for system design.

WEEE Directive:
At the end of their useful life, the packaging, product and batteries should be disposed of via a suitable recycling centre. Do not dispose of with your normal household waste. Do not burn.

At the end of their useful life, the packaging, product and batteries should be disposed of via a suitable recycling centre and in accordance with national or local legislation.

Honeywell Gent reserves the right to revise this publication from time to time and make changes to the content hereof without obligation to notify any person of such revisions of changes.

Hamilton Industrial Park, Waterside Road, Leicester LE5 1TN, UK
Website: www.gent.co.uk
Telephone +44 (0) 203 409 1779 Fax (UK): +44 (0)116 246 2300