

**S-Cubed Mark 3 - EP**  
**Data and Installation**



These instructions cover the installation of wall mounted S-Cubed Mark 3 devices. They can be installed in compatible GENT Vigilon fire alarm systems. They are Environmentally Protected 'EP' devices designed for outdoor use and in internal areas having harsh environments inside a building. (VAD - Visual Alarm Device)

Sounder Device (EP)	
S3EP-S-R	S3 Sounder/Red Body/EP
Visual Alarm Device (EP)	
S3EP-VAD-HPW-R	S3 VAD/High perform. White VAD/Red Body/EP
S3EP-VAD-HPR-R	S3 VAD/High perform. Red VAD/Red Body/EP
Voice Sounder and Visual Alarm Device (EP)	
S3EP-V-VAD-HPW-R	S3 Voice Sounder/High perform. White VAD/Red Body/EP
S3EP-V-VAD-HPR-R	S3 Voice Sounder/High perform. Red VAD/Red Body/EP

The S-Cubed Mark 3 devices are configured during commissioning to operate to site specific requirement.

The S-Cubed product range incorporates innovative design features protected by Patents GB2388994, GB2388995 and GB2388916.

**Do's**

- Follow the recommendations that relate to alarm sounders, see Section 16 of BS5839 : Part 1 : 2013.
- Locate Visual Alarm Devices in accordance with Loss Prevention Council Code of Practice CoP 0001. <http://www.redbooklive.com/lps.jsp>
- Check and ensure the S-Cubed Mark 3 devices are compatible with the system control panel software, see technical data
- Use correct methods to open and close a device
- Mount the device with the marking 'TOP' uppermost, to allow Visual Alarm and the remote control operation
- Ensure the PCB cover is in place over the PCB to protect external cables and components on PCB
- Ensure the earth continuity strap is fitted in the base if required
- Install a Visual Alarm Device horizontally using levelling tool
- Clean any dust off the lens of a Visual Alarm using a lint free cloth
- Mount unit on a flat external wall surface

**Don'ts**

- Don't scratch the lens on a Visual Alarm Device
- Don't flush mount the Base
- Don't have excessive incoming cable slack
- Don't locate a device such that the audible and visual outputs are obstructed
- Don't mount the device above obstructions, such as shelves that prevent IR remote control operation
- Don't paint the device enclosure

**Installation**

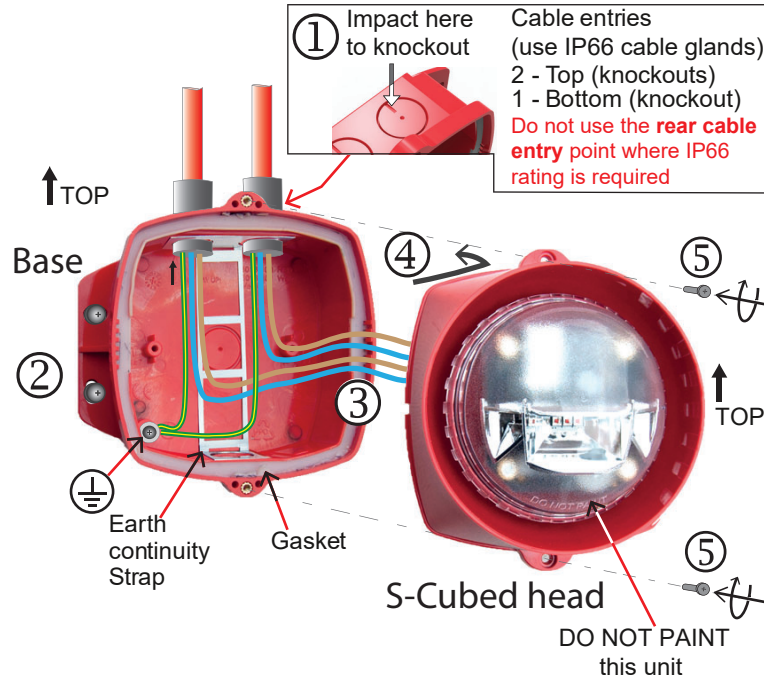

- a) Knock out the required cable entry points ① from the Base.
- b) Secure the Base to the wall whilst ensuring the Top of the Base is in correct orientation with marked arrow pointing upwards.
- c) Use suitable fixings to secure the Base to wall ②.
- d) Terminate the external cable at the entry points ③ using suitable glands leaving no more than 10cm (4") tail wire length ③.

**Wiring**

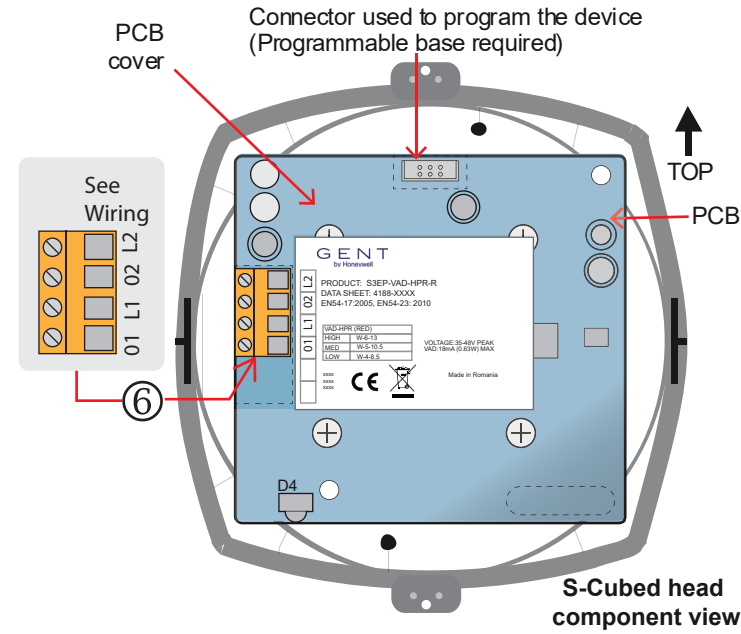
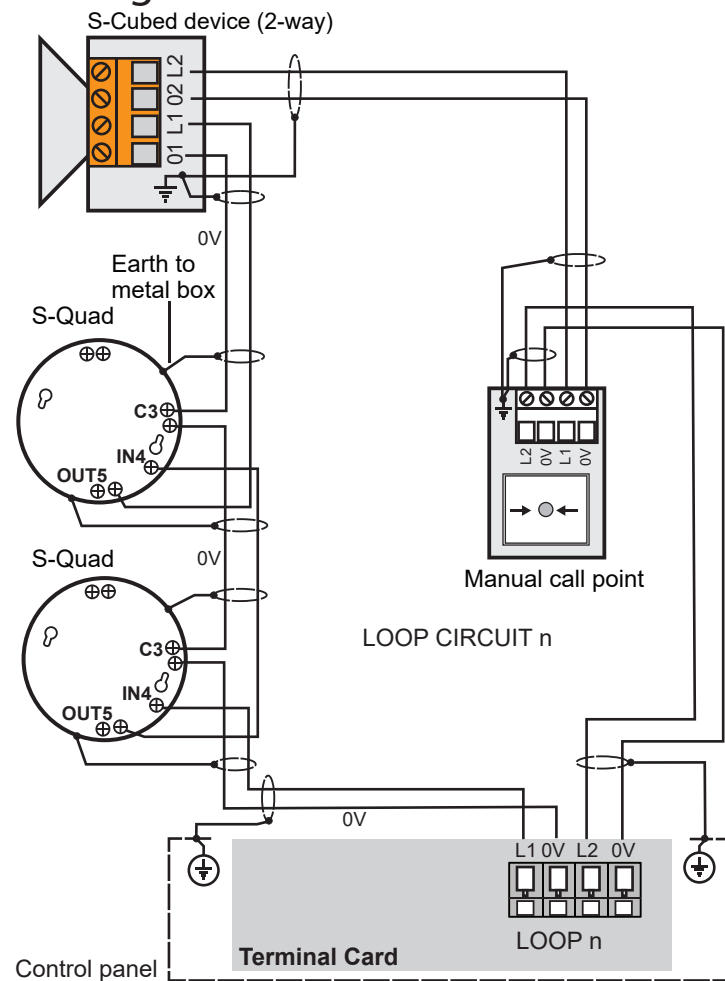

- e) Ensure the PCB cover is in place over the PCB. Connect the wires to the terminal block ⑥, see also Wiring.

- f) Align the S-Cubed head to the Base ④ and press the head against the Base until a click is heard. Ensure the two parts are locked together.

- g) Secure the assemblies using 2 - M3 x 10mm screws ⑤ supplied.

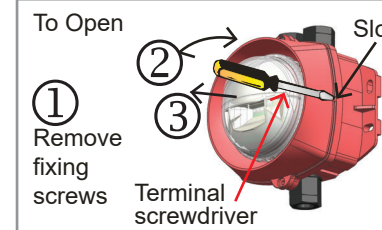

**Technical data**

**Designed to the requirements of Standards**

Sounder - EN54-3 : 2001, A1:2002, A2:2006  
Visual Alarm Device (VAD) - EN54-23 : 2010  
Short-circuit isolator - EN54-17 : 2005

**Sound level** - for Sounder only  
103dB(A) +/-3dB 90° at 1m

**VAD flash rate**  
pulsed output every 2s

**Weight**  
S-Cubed VAD + base 308g

**Compatibility**  
see section headed Compatibility

**Ambient operating temperature**  
-15°C to +55°C

**Storage temperature**  
-20°C to +60°C

**Relative Humidity**  
95% non condensing  
(+5°C to +45°C)

**Operating voltage**  
35V - 48V

**Material - body and lens**  
Polycarbonate

(\* - not LPCB approved)

**IP Ratings** - IP 33 (LPCB Approved)  
Independent testing performed to IP66\*

**Colour**  
Red body RAL 3020

**Flammability** - V2 Rated

**IR remote - volume control**  
Operating range up to 3m

**EN54-17 data - short circuit isolator**  
Vmax 48V ICmax 0.8A  
Vnom 40V ISmax 1.25A  
Vmin 24V ILmax 50µA  
VSOmax 16V ZCmax 0.13Ω  
VSOmin 8V

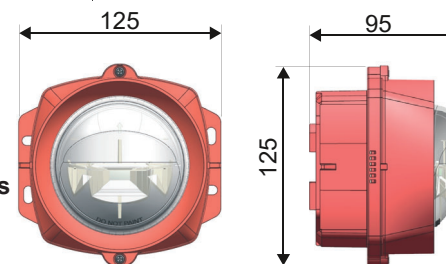

**Tones and Messages**

**Tones**

Signal 1 Intermittent tone 970Hz ±10% @ 1Hz  
Signal 2 Alternating tone 730Hz ±10% / 970Hz ±10% @ 2Hz  
Signal 3 High Tone (Continuous 970Hz ±10%)

**Speech messages**

**Message 1**

Bell tone

**Message 2 (with Signal 3)**

Attention please this is an emergency please leave the building by the nearest available exit. (female voice)

**Message 3# (with Signal 1)**

An incident has been reported in this building please await further instructions. (female voice)

**Message 4**

This is a test message no action is required. (female voice)

**Message 5 # (with Signal 2)**

This is a fire alarm please leave the building immediately by the nearest available exit. (male voice)

# Approved to EN54-3 Annex C.

**Message and attention Tone**

Programmable period normally set at 10 seconds can be configured up to 30 seconds.

The default period is 10 seconds. This may be altered (using the commissioning tool) to suit custom messages or use of non standard tones

Flash memory can hold up to 20 seconds of audio and bell tone.

**Volume control**

**Wall S-Cubed**

The volume of a Sounder S-Cubed can be adjusted by the Commissioning tool or by a remote control with panel in Test mode. Save the new volume at the panel after adjustment.

The sound levels in the areas should be tested in accordance with the British Standard requirements and to meet the site specific needs as agreed with the customer.

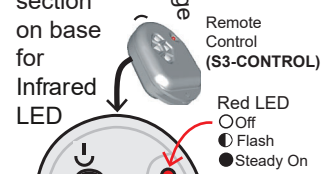

**Trouble shooting**  
If the remote control fails to operate in close proximity to the thinned section of the S-Cubed device, then a possible cause may be the battery. Replace the battery.

- ① Perform a short press on the Power button to turn On the remote control. The Red LED will flash x1 every 2 seconds
- ② Press the f function button to toggle between: **Volume** function and note the Red LED flashes x1 every 2 seconds  
**Tone/Speech message** function and note the Red LED flashes x2 every 2 seconds
- ③ Press the + or - to increase or decrease **volume** or to select next or previous **tone/Speech**  
**Note:** The light on the S-Cubed unit if fitted will flash rapidly when the volume is being adjusted using the remote control.
- ④ Press and hold the Power button to save the settings. The Red LED will remain On whilst the button is held pressed. The data is saved to the unit when the tone/speech on the S-Cubed stops briefly. Release the button on the remote control and the Red LED will switch Off.

# Visual Alarm Coverage data

A wall mounted Visual Alarm Device (VAD) covers a cuboid volume with a minimum effective illuminance of 0.4 Lux. The coverage volume is stated as:

- W-x-y**
- where 'W' is the wall mounted category
  - 'X' is the maximum mounting height in metres (minimum 2.4m)
  - 'y' is the maximum length and width of cubic volume in metres.

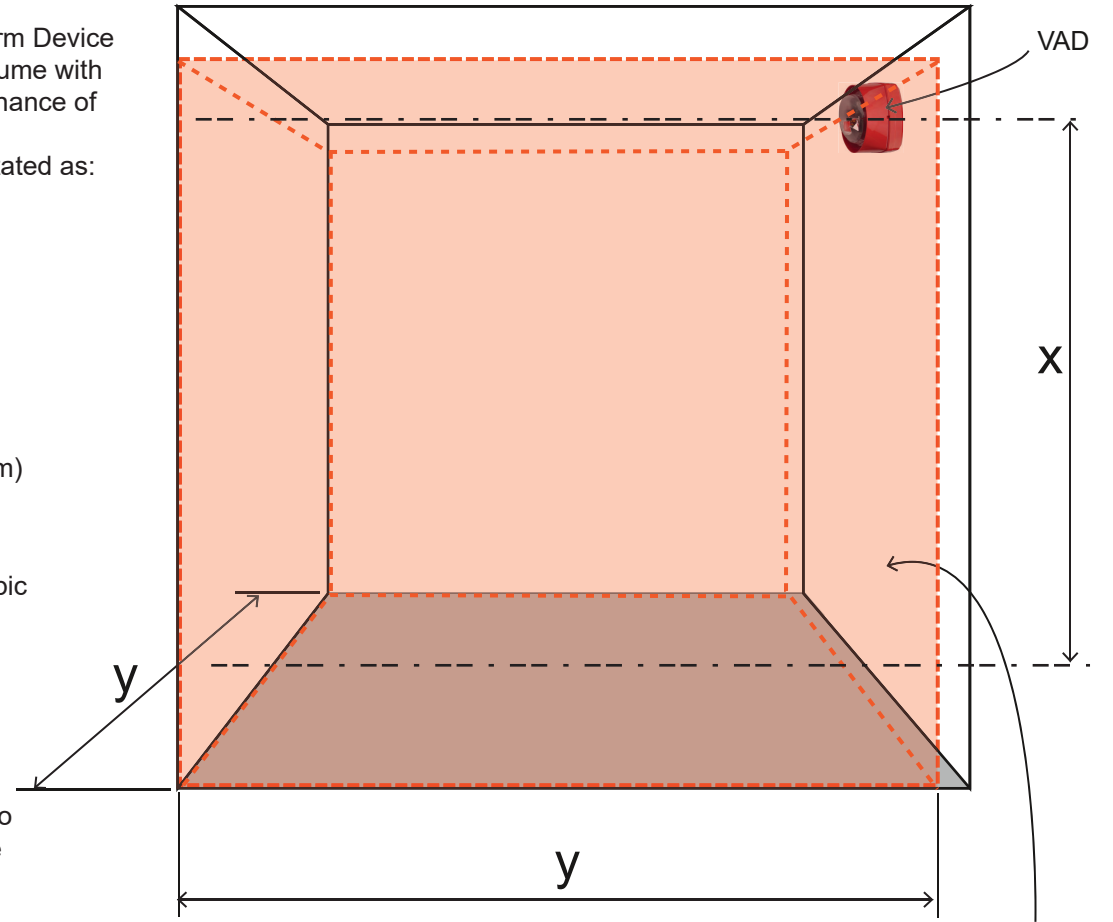

This diagram shows how to relate the cuboid when the device is mounted at height 'X'.

Cuboid surface with minimum illumination of 0.4Lm/m<sup>2</sup>

## Performance data for S-Cubed Mark 3 EP devices

**Table 1** Shows the worst case performance data for S-Cubed White VAD (high perform. -HPW) and S-Cubed Red VAD (high perform. -HPR)

Power setting	Maximum loop current and power for the VAD only	Maximum loop current and power for the sounder (minimum voltage)	Maximum total loop current and power for VAD and sounder	EN54-23 rating & coverage volume in cubic metres			
				WHITE VAD (high performance HPW)		RED VAD (high performance HPR)	
High	18mA (630mW)	Turbo = 5mA (175mW)	23mA (805mW)	W - 5 - 12.5	781 m <sup>3</sup>	W - 6.7 - 14	1313 m <sup>3</sup>
		Non Turbo = 3mA (105mW)	21mA (735mW)				
Medium	14mA (490mW)	Turbo = 5mA (175mW)	19mA (665mW)	W - 4.5 - 11.3	574 m <sup>3</sup>	W - 6.5 - 12.5	1015 m <sup>3</sup>
		Non Turbo = 3mA (105mW)	17mA (595mW)				
Low	8mA (280mW)	Turbo = 5mA (175mW)	13mA (455mW)	W - 3 - 8.5	216 m <sup>3</sup>	W - 5 - 9.5	451 m <sup>3</sup>
		Non Turbo = 3mA (105mW)	11mA (385mW)				

## CoP 0001 Coverage distance multiplication factors

The table below shows how the EN54-23 coverage specification will vary with the ambient light level and if the VAD can be viewed directly or indirectly i.e. if it relies on reflections to be viewed.

It is however advisable to site the VAD so that direct viewing is possible to maximize the VAD coverage.

**Table 2**

Ambient light level (Lux)	Wall mount direct viewing	Wall mount indirect viewing
<100	5.2	1.8
100-200	4.4	1.7
200-300	3.2	1.4
300-400	2.3	1.2
400-500	1.8	1.0
500-600	1.3	0.9
600-700	1.0	0.7*
700-800	0.7	0.6*

\* Where ambient light levels may, at any time, exceed 600 lux, direct viewing is preferred.

Select the correction factor from Table 2 and multiply it with the cuboid dimensions. The coverage of the VAD will increase or decrease depending on the light level and line of sight.

**TIP** To survey and determine the ambient light levels a LUX meter that complies with BS667 should be used.

## Symbols on Product

- Protective Earth connection terminal.
- The WEEE symbol. It indicates this product is to be recycled and not thrown away.
- The CE compliance logo. This product is in conformity with the relevant European Union harmonisation legislation.
- The RoHS compliance logo. The RoHS directive restricts the use of certain hazardous substances commonly used in electronic and electronic equipment.
- The UKCA (UK Conformity Assessed) marking is a new UK product marking that is used for goods being placed on the market in Great Britain (England, Wales and Scotland).

**UKCA** 0832 **CE** 2831

Gent by Honeywell  
 Manufactured by: Honeywell Life Safety Systems-Romania  
 Street: Str. Salcamilor 2 bis- Lugoj

15

DoP Product No.  
 091-CPR-2014 S3EP-S-R  
 092-CPR-2014 S3EP-VAD-HPW-R  
 093-CPR-2014 S3EP-VAD-HPR-R  
 094-CPR-2014 S3EP-V-VAD-HPW-R  
 095-CPR-2014 S3EP-V-VAD-HPR-R

EN54-3:2001, A1:2002, A2:2006, EN54-17:2005, EN54-23:2010

S3EP-S-R (EN54-3,17)  
 S3EP-VAD-HPW-R (EN54-17, 23)  
 S3EP-VAD-HPR-R (EN54-17, 23)  
 S3EP-V-VAD-HPW-R (EN54-3,17, 23)  
 S3EP-V-VAD-HPR-R (EN54-3-17,23)

Intended for use in fire detection and fire alarm systems in and around buildings

Refer to DoP 091-CPR-2014 to DoP 095-CPR-2014 for level or class of performance declared, for details see website www.gent.co.uk

**LPCB**

042bj  
 042bs  
 042bt

For model reference associated with LPCB certificate see list below

Product No. LPCB No.  
 S3EP-S-R 042bj/25  
 S3EP-VAD-HPW-R 042bt/03  
 S3EP-VAD-HPR-R 042bt/04  
 S3EP-V-VAD-HPW-R 042bs/07  
 S3EP-V-VAD-HPR-R 042bs/10

## Compatibility

### Vigilon

The S-Cubed Mark 3 devices with VAD can be used in a Vigilon panel based system providing the software versions stated below are met.

All VAD devices can either operate in 'Compliant mode' to meet the requirements of EN54 Part 23 or as Visual Indicator Device (VID) that operate in 'Non Compliant mode', meaning they DO NOT meet EN54 Part 23.

**i** The system design may incorporate S-Cubed with VAD and S-Quad with VAD to achieve visual alarm coverage.

≥ means equal to or greater than	EN Vigilon Panels				
	Vigilon 4 loop	Vigilon Compact	Vigilon Compact VA	Vigilon 4-6 loop	All panels
Cards	MCC	MCB	MCB	MCC	LPC
All S-Cubed Mark 3 devices (VADs in 'Compliant mode')	≥ V4.52	≥ V4.52	-	≥ V4.52	≥ V4.48
# All S-Cubed Mark 3 devices (VADs operate as VIDs in 'Non compliant mode')	≥ V4.37	≥ V4.37	≥ V4.37	≥ V4.37	≥ V4.30

A Vigilon System is configured using Vigilon Commissioning Tool ≥ V1.30.

# VAD data shown in Table 1 are not applicable with the panel software stated here.

≥ means equal to or greater than	BS Vigilon 4-loop Panel	
Cards	MCC	LPC
# All S-Cubed Mark 3 with VAD devices (VADs operate as VIDs in 'Non compliant mode')	≥ V3.90	≥ V3.90

A Vigilon System is configured with Vigilon Commissioning Tool V1.30.

### Nano

Note: All S-Cubed with VAD can be installed in a GENT Nano fire alarm system with panel card software stated below. The VADs will only operate at a Low Power setting to meet EN54 Part 23.

≥ means equal to or greater than	Nano Panel	
Cards	MCB	LP
All S-Cubed Mark 3 with VAD devices	≥ V3.12	≥ V1.08

Nano system is configured using Nano Commissioning Tool ≥ V3.0.

**i** It is recommended that the 'Battery Standby and Loop load Calculator' is used for system design.

**WEEE Directive:**  
 At the end of their useful life, the packaging, product and batteries should be disposed of via a suitable recycling centre. Do not dispose of with your normal household waste. Do not burn.

**At the end of their useful life, the packaging, product and batteries should be disposed of via a suitable recycling centre and in accordance with national or local legislation.**

Honeywell Gent reserves the right to revise this publication from time to time and make changes to the content hereof without obligation to notify any person of such revisions of changes.

Honeywell Building Technologies, Building 5 Carlton Park, King Edward Avenue, Narborough, Leicester, LE19 0AL  
 Website: www.gent.co.uk

Telephone: +44 (0)203 409 1779. Tech. Support www.gentexpert.co.uk