

# S4 ASD Interface

(S4-34440-ASD)



The S4 ASD interface unit (Part No: S4-34440-ASD) is designed to connect to a FFAST unit, Fire Alarm Aspiration Sensing Technology® .

The ASD Interface unit monitors the FFAST unit for fire and fault events and signals the Vigilon panel to take cause and effect actions.

The ASD Interface unit incorporates an EN54-4 compliant mains derived power supply that is battery backed to provide a standby supply. The auxiliary power output from the unit is used drive the FFAST unit.



The ASD Interface Unit is supplied bundled with FFAST:

- FL0111E-HS-VIG-INT (S4-34440-ASD + FL0111E-HS + EOL PCB)
- FL0112E-HS-VIG-INT (S4-34440-ASD + FL0112E-HS + EOL PCB)
- FL0122E-HS-VIG-INT (S4-34440-ASD + FL0122E-HS + EOL PCB)
- 8100-VIG-INT (S4-34440-ASD + 8100E + EOL PCB)
- 7100XE-VIG-INT (S4-34440-ASD + 7100XE + Spares Pack)
- 9400XE-VIG-INT (S4-34440-ASD + 9400XE + Spares pack)

### Technical Data

Standards - designed to meet	EN54:part 4:1997 + A1:2002 EN54:part 17:2005 EN54:part 18:2005
Overall dimensions	478mm x 322mm x 145mm
Assembled weight (approx.)	5.25Kg (excluding batteries and optional modules fitted)
Enclosure	Steel
Colour	Door: RAL 7024 Graphite Grey and Toucan C-Mix 2000 white 67W50 Backbox: RAL 7024 Graphite Grey

Storage temperature	-20°C to +70°C		
Ambient operating temperature	-10°C to +45°C		
Relative Humidity (Non condensing)	up to 95% Temperature +5°C to +45°C		
Ingress Protection	IP31(estimated)		
Mains voltage Rated current	230V -15% +10% 50Hz/60Hz 0.7A		
Zone Nominal voltage Quiescent current	16V or 22.5V (default) ±15% 20mA per zone (default)		
	Zone short circuit current limited to < 30mA. Refer to the commissioning information for details on how to configure the ASD interface for: - Single Port (1 Channel) or - Dual Port (2 Channels) application.		
Auxiliary Output	<b>Sector outputs:</b> 0.5A max. each at 24V ± 3V, electronically current limited to approximately 1A at 25°C  <b>Auxiliary power output:</b> 0 to 0.5A with 12V ±0.5V or 24V ±0.5V 0.5A to 0.65A max. with 12V ±2V or 24V ±2V  <b>Max. total output current: 1.5A</b>		
Batteries	2 x 12V 14Ahr (4.2Kg each)		
Compatibility	Vigilon : MCC ≥ V4.53 : LPC ≥ V4.49 Commissioning tool ≥ V1.31		
Operating Voltage	35V - 48V		
EN54-17 : 2005 (section 4.8) data:	Vmax 48V Vnom 40V Vmin 24V Vso max 16V Vso min 8V	Ic max 0.8A Is max 1.25A IL max 50µA ZC max 0.2Ω	
EN54-18 : 2005 data	Vmax 42V Vmin 24V		
EN54-4 : 1997data	I <sub>maxa</sub> 1.5A	I <sub>maxb</sub> 2.5A	R <sub>i</sub> max 1.3R
	I <sub>min</sub>	80µA	
	UVLo	18.5Vdc ±5%	
	V <sub>batt</sub> min (with no mains)	22.5Vdc ±5%	
Emission	BS EN 61000-6-3: 2007 + A1:2001 EMC for residential, commercial & light Industry.		
Immunity	BS EN 50130-4: 2001 for alarm systems		
Terminals	Terminals for spur circuit off main loop		

The ASD Interface unit has room to accommodate optional modules onto its DIN rails.

# Installation



It is recommended that a FFAST unit and an ASD interface unit are both installed with due consideration to the requirements for BS5839-1. Also refer to the general guidance in FIA Code of Practice for Installation of Aspiring detector.

The batteries 12V 14Ahr are supplied in a separate packages.

Parts	Qty
Fuse 3.15A AS Ceramic (20mm x 5mm)	1
Fuse 3.15A QB Glass (20mm x 5mm)	1
Battery Link	1
Battery Lead	1
Resistor 5.6K 0.6W	4
Resistor 470R 0.6W	8
Resistor 10K 0.5W	4

Parts	Qty
Capacitor 22uF	4
Keys fitted to the enclosure.	1 pair
PS-12140 12V 14Ahr Battery	2

### FFAST LT EOL Terminal PCB



FFAST LT EOL Terminal PCB shown (similar PCB for FFAST 8100E)  
 FFAST XT and XS make use of end of lines in spares pack

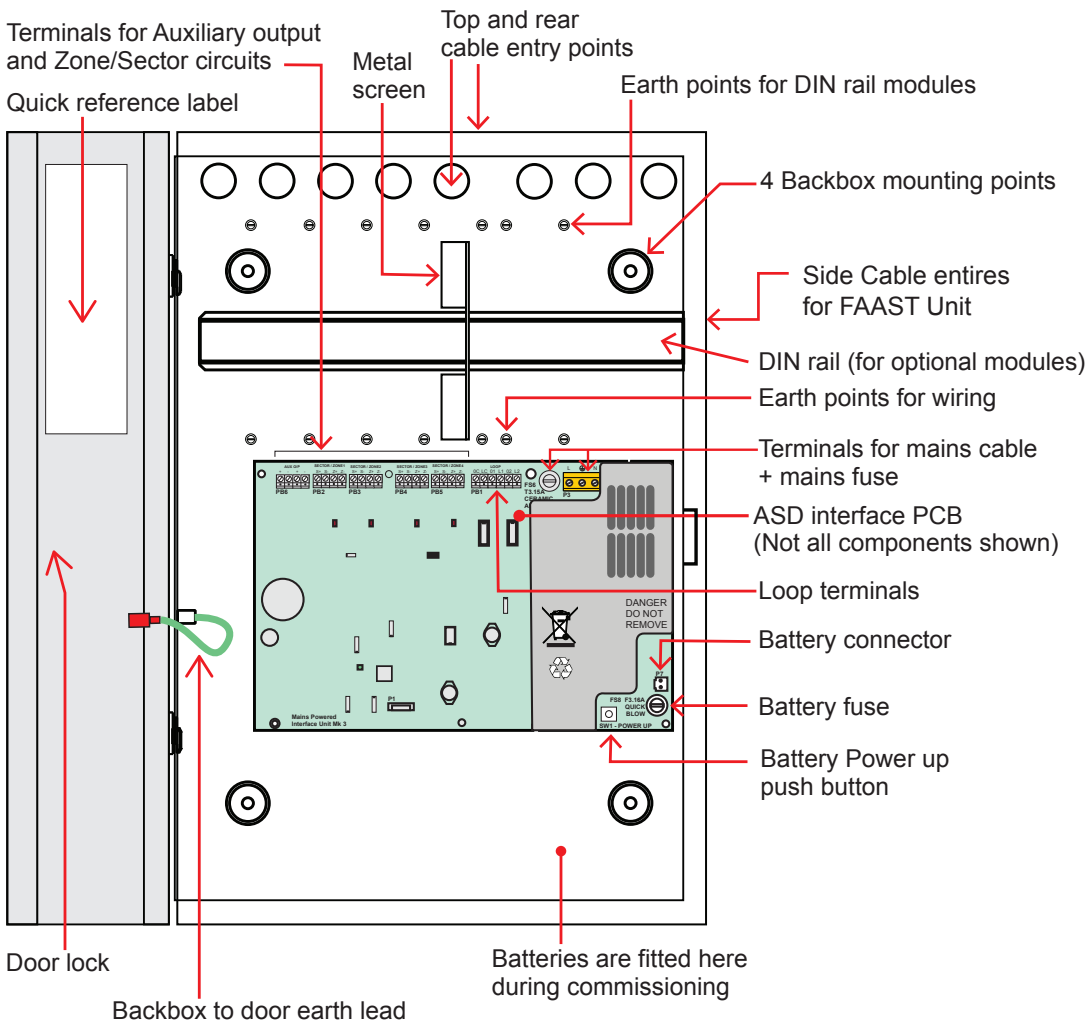

### Relay module

Optional relay module (Part number 19104-52) if used should be mounted on the DIN rail.

**Cable termination**

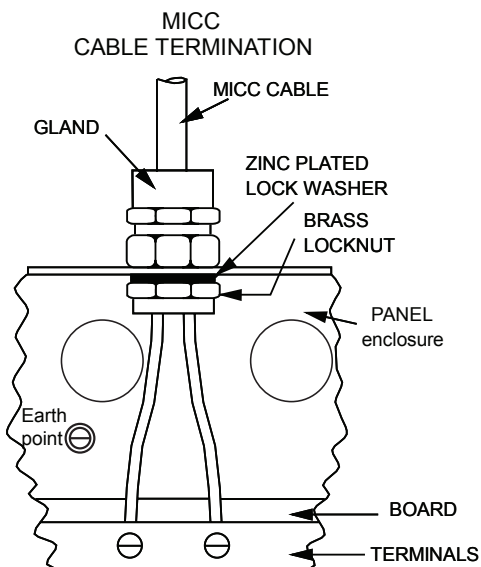
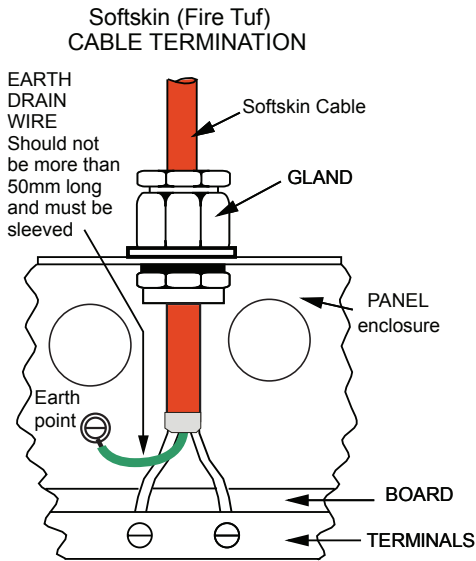

**Loop wiring**

An ASD Interface unit is connected to a Vigilon device loop as shown below using recommended fire cable.

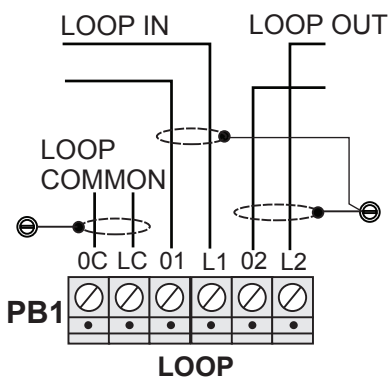

**Mains supply**

The mains supply cable must be a standard fire resisting type and should meet PH30 classification, such as any of the standard and enhanced loop cable. Requires a minimum conductor cross sectional area of 0.75mm<sup>2</sup>.

**!** Ensure that the mains supply cable enters the enclosure through a dedicated cable entry, located adjacent to the mains terminal block and that is also segregated from FFAST unit and loop wiring.

**i** These fire alarm system products are not designed to be powered from IT Power systems.

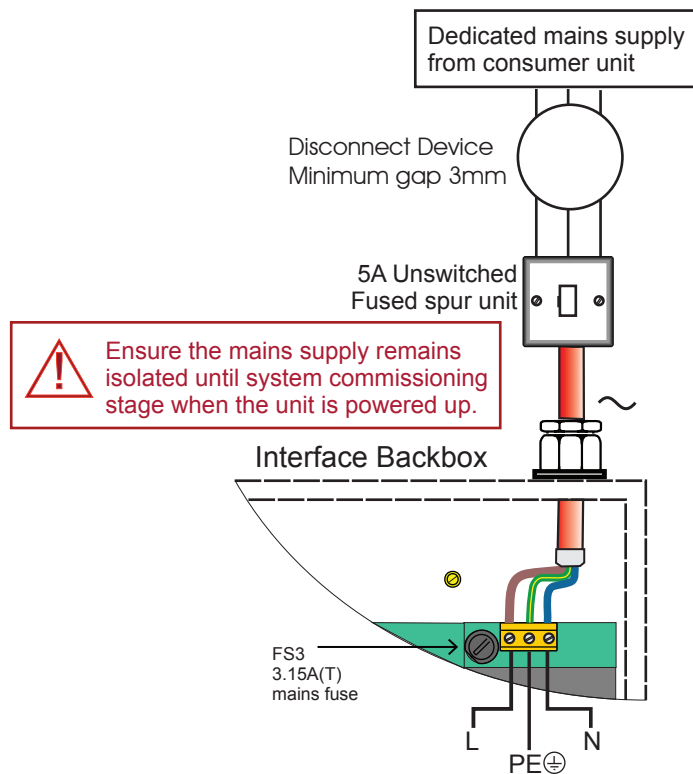

**!** Ensure the mains supply remains isolated until system commissioning stage when the unit is powered up.

All mains powered equipment must be earthed. Mains supply to any fire alarm control and indicating equipment must be via an unswitched 5A fused spur unit. A disconnect device must be provided to disconnect both poles and must have a minimum gap of 3mm. The disconnect device should be available as part of the building installation and must be easily accessible after installation is complete.

**Wiring test**

**!** DO NOT undertake high voltage insulation tests WITH THE CABLES CONNECTED to the Interface unit and external equipment. Such a test may damage the electronics circuitry in external equipment and in the Interface unit.

## Cables for wiring a FAAST unit

The ASD Interface unit is connected to a FAAST Unit using approved fire cable:

- A 2-core fire cable should be used to make the Auxiliary O/P power supply connection, see the Vigilon Installation manual for list of approved 2-core fire cable used for loop wiring.
- A 4-core fire cable may be used for channel connections between ASD Interface unit and a FAAST unit.

## Location



To meet the requirement of BS5839-1 the ASD interface Unit must be installed adjacent to the FAAST unit.

### Adjacent installation



Remote installation require special consideration, so adjacent installation is the recommended option.



Where the ASD Interface Unit and FAAST Unit are not adjacently installed then the power supply connections must be duplicated and short circuit protection must be provided so that a short circuit on one connection does not prevent power from being supplied by the other connection.

### Cable routing to FAAST Units

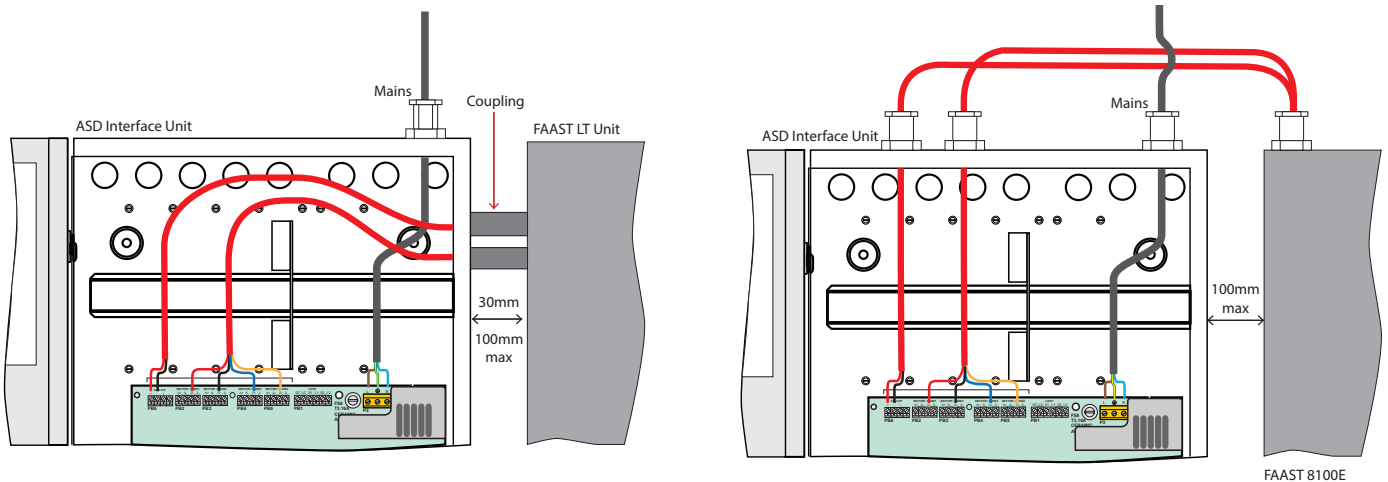

# FAAST LT (FL0111E-HS or F0L112E-HS) Single Port (1-Channel) unit installation

## How to install FAAST LT Single/Dual Port EOL Terminal PCB

- ③ Connect the external wiring to the orange terminal block on FAAST LT EOL Terminal PCB, see wiring diagram.
- ② Fit terminal blocks supplied with the FAAST Unit to the FAAST PCB, as illustrated. Open all the terminal screws to help with the installation of FAAST LT EOL Terminal PCB.
- ① Open the outer cover

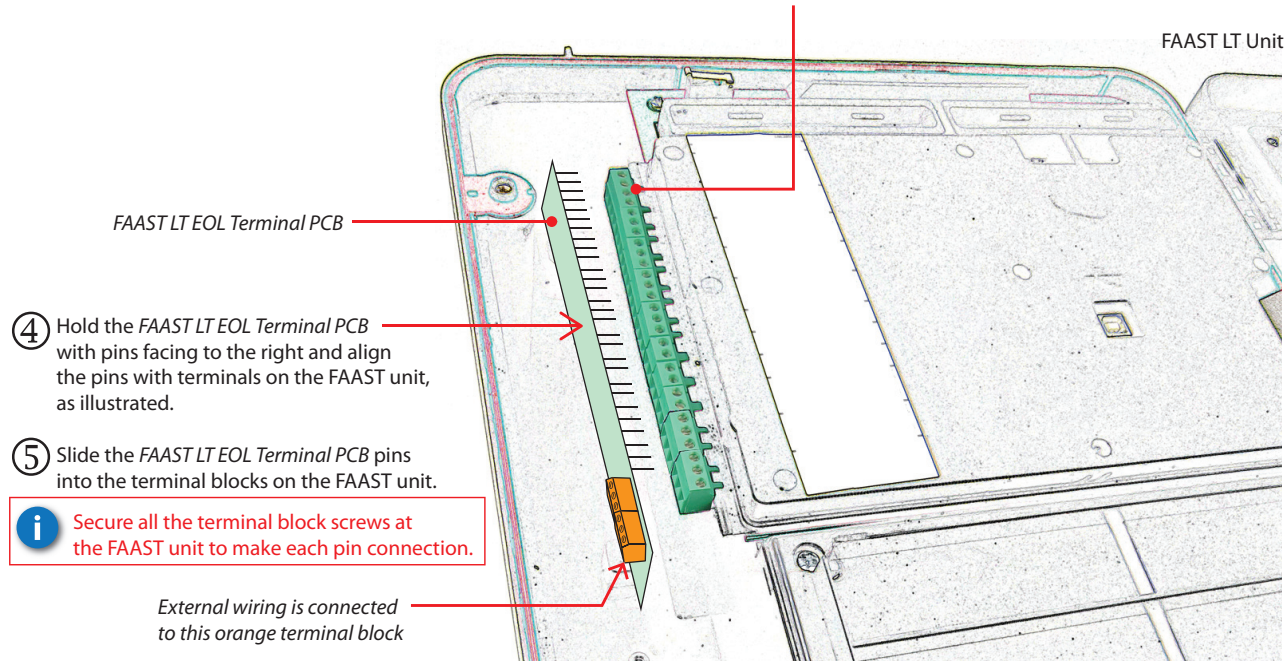

## Wiring a FAAST LT Single Port (1-Channel) FL0111E-HS or FL0112E-HS to a ASD Interface Unit (S4-34440-ASD)

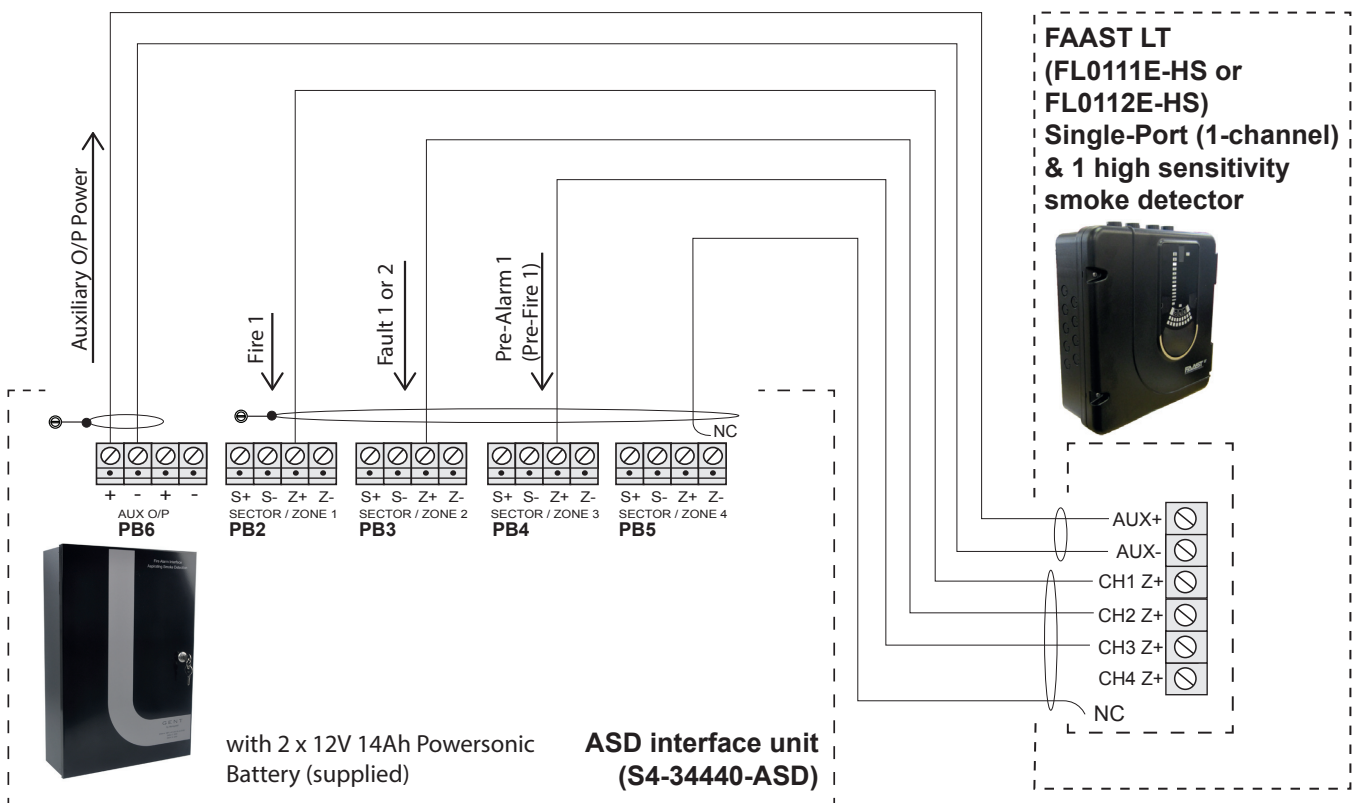

⊙ Connection to metal enclosure

NC - No connection

# FAAST LT (FL0122E-HS) Dual Port (2-Channel) unit installation

## How to install FAAST LT Single/Dual Port EOL Terminal PCB

- ③ Connect the external wiring to the orange terminal block on FAAST LT EOL Terminal PCB, see wiring diagram.
- ② Fit terminal blocks supplied with the FAAST Unit to the FAAST PCB, as illustrated. Open all the terminal screws to help with the installation of FAAST LT EOL Terminal PCB.
- ① Open the outer cover

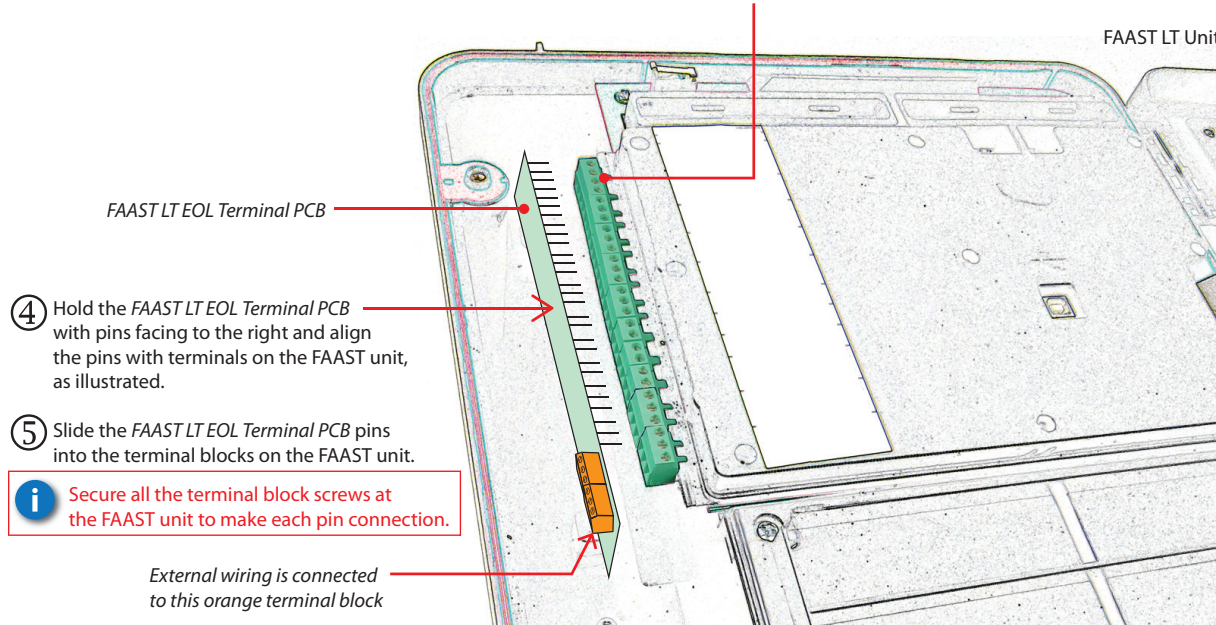

- ④ Hold the FAAST LT EOL Terminal PCB with pins facing to the right and align the pins with terminals on the FAAST unit, as illustrated.

- ⑤ Slide the FAAST LT EOL Terminal PCB pins into the terminal blocks on the FAAST unit.

**i** Secure all the terminal block screws at the FAAST unit to make each pin connection.

External wiring is connected to this orange terminal block

## Wiring a FAAST LT Dual Port (2-Channel) FL0122E-HS unit to a ASD Interface Unit (S4-34440-ASD)

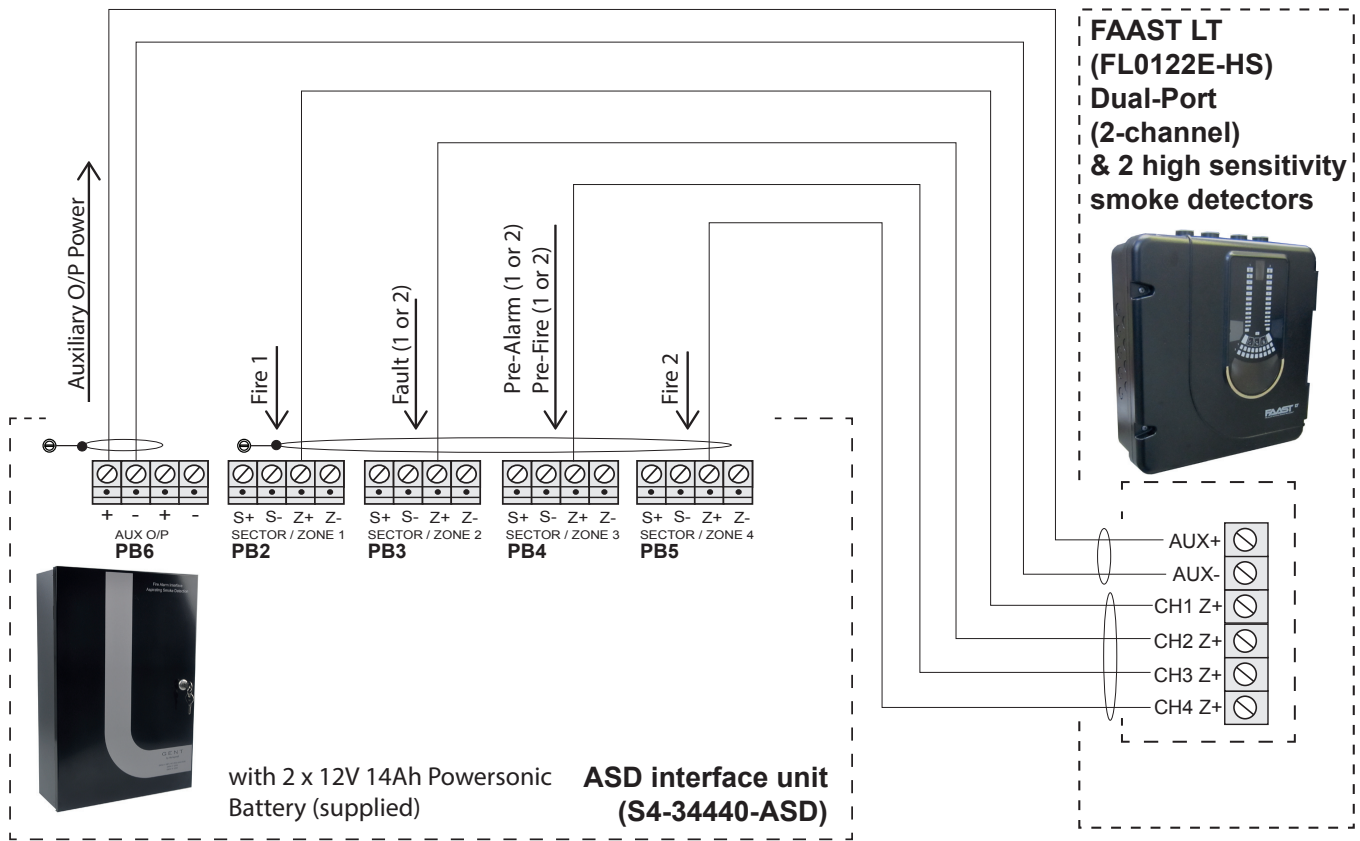

⊖ Connection to metal enclosure

# FAAST (8100E) True aspirating unit Installation

## How to install FAAST 8100E EOL Terminal PCB

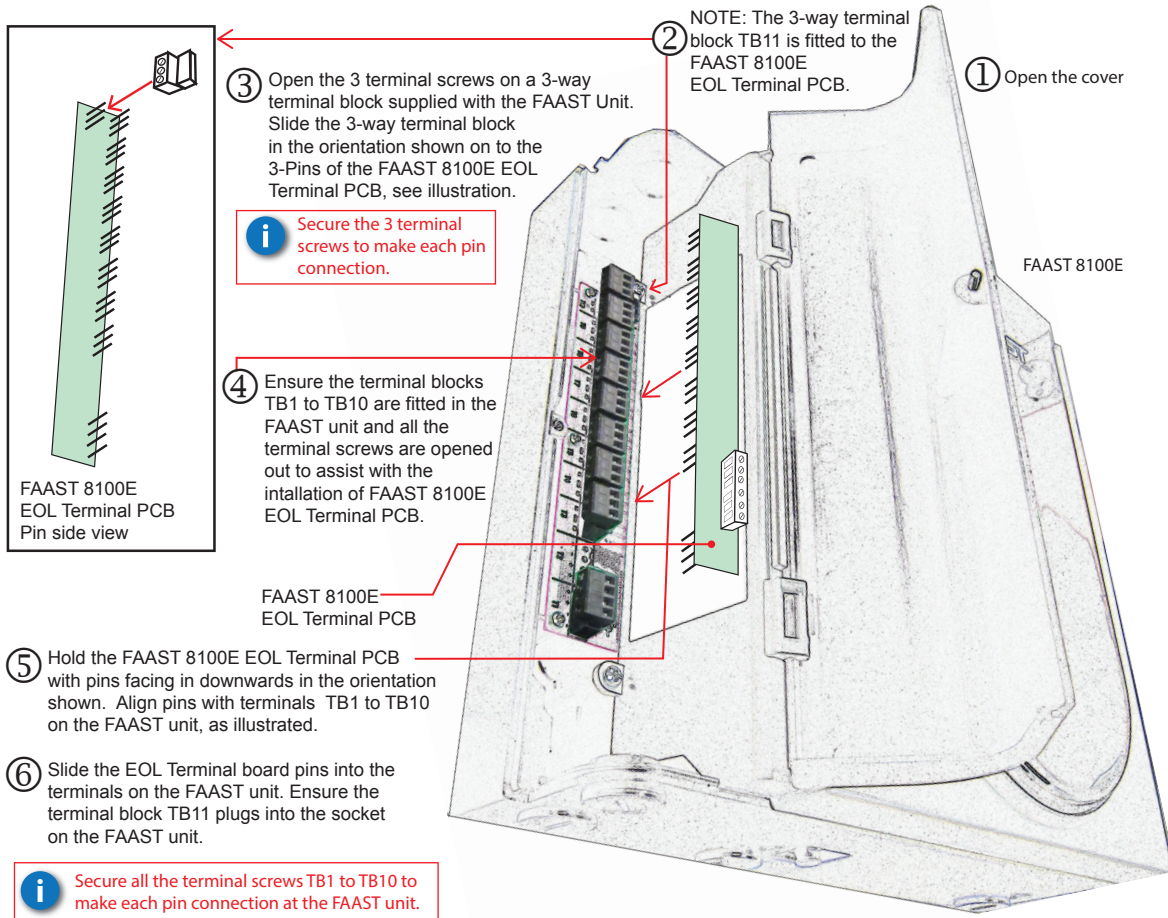

## Wiring a FAAST 8100E True aspirating unit to an ASD Interface Unit (S4-34440-ASD)

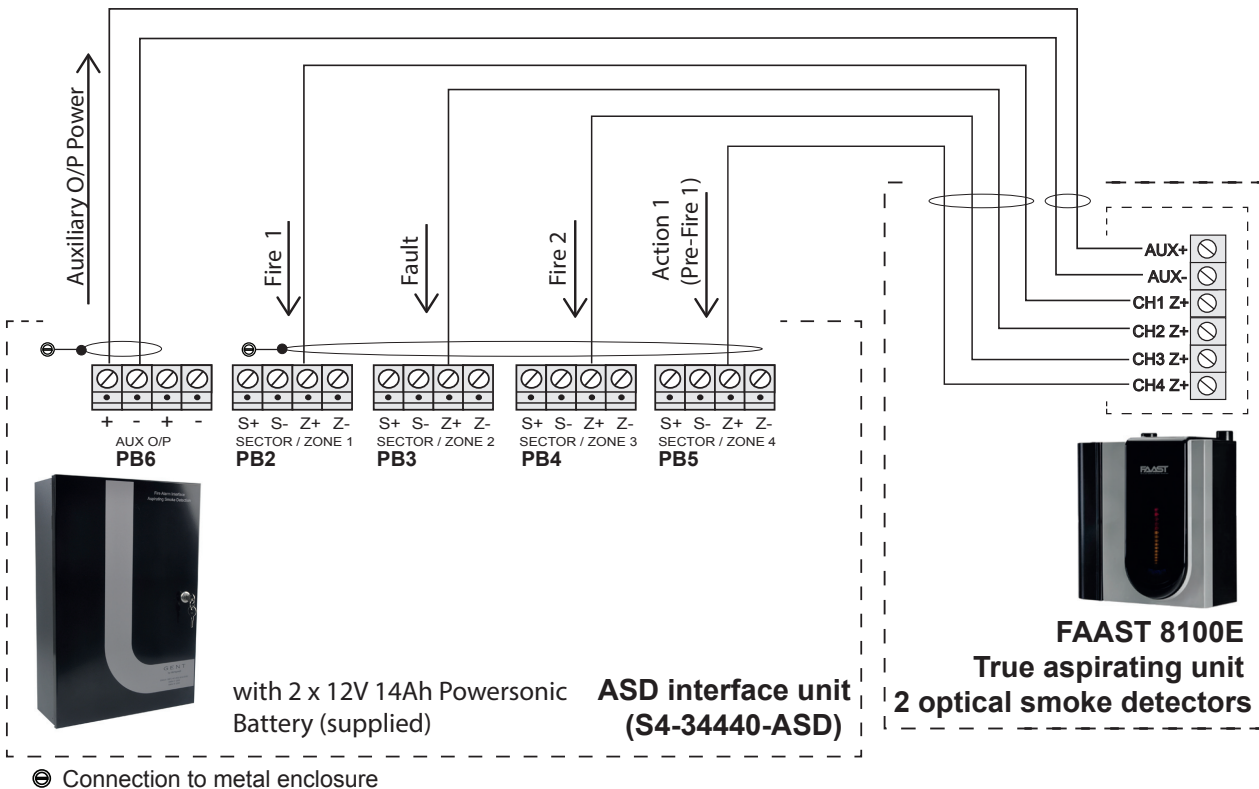

# FAAST XS (7100XE) Dual Port (2-Channel) unit installation

## Wiring a FAAST XS Dual Port (2-Channel) 7100XE unit to a ASD Interface Unit (S4-34440-ASD)

**!** If a lower default threshold (% OBS / FT) is required then wire to Fire output **Fire 1 Relay contacts (T3)** instead of **Fire 2 Relay contacts (T2)**.

**!** Ensure the End of Line devices are fitted to Zone 1 and Zone 4 terminals at the ASD interface as illustrated below.

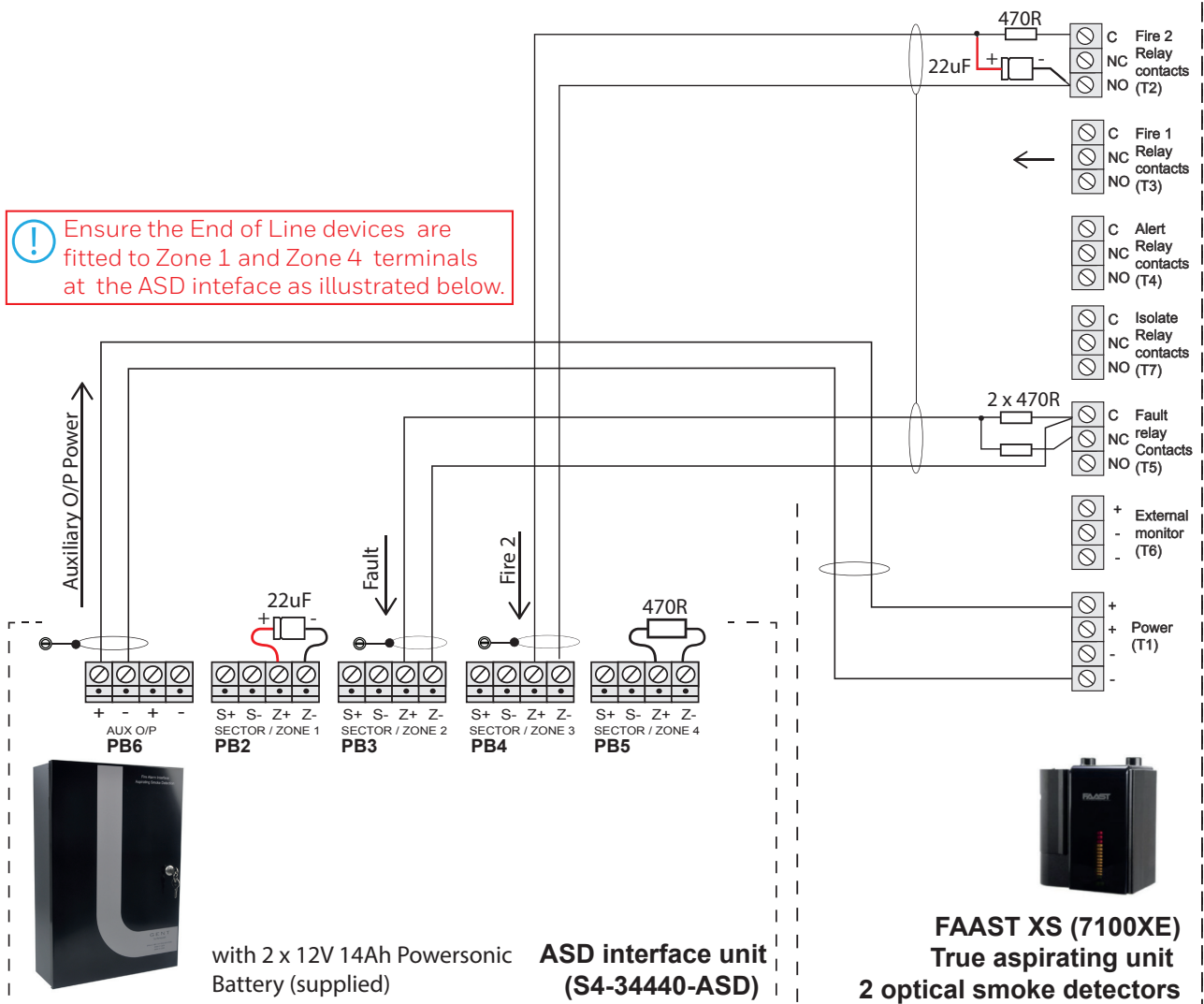

with 2 x 12V 14Ah Powersonic Battery (supplied)

**ASD interface unit (S4-34440-ASD)**

**FAAST XS (7100XE) True aspirating unit 2 optical smoke detectors**

⊖ Connection to metal enclosure **Set the ASD Interface in the Vigilon system as a FAAST 8100E using Commissioning tool.**

## Cable routing from ASD interface to FAAST XT or XS unit

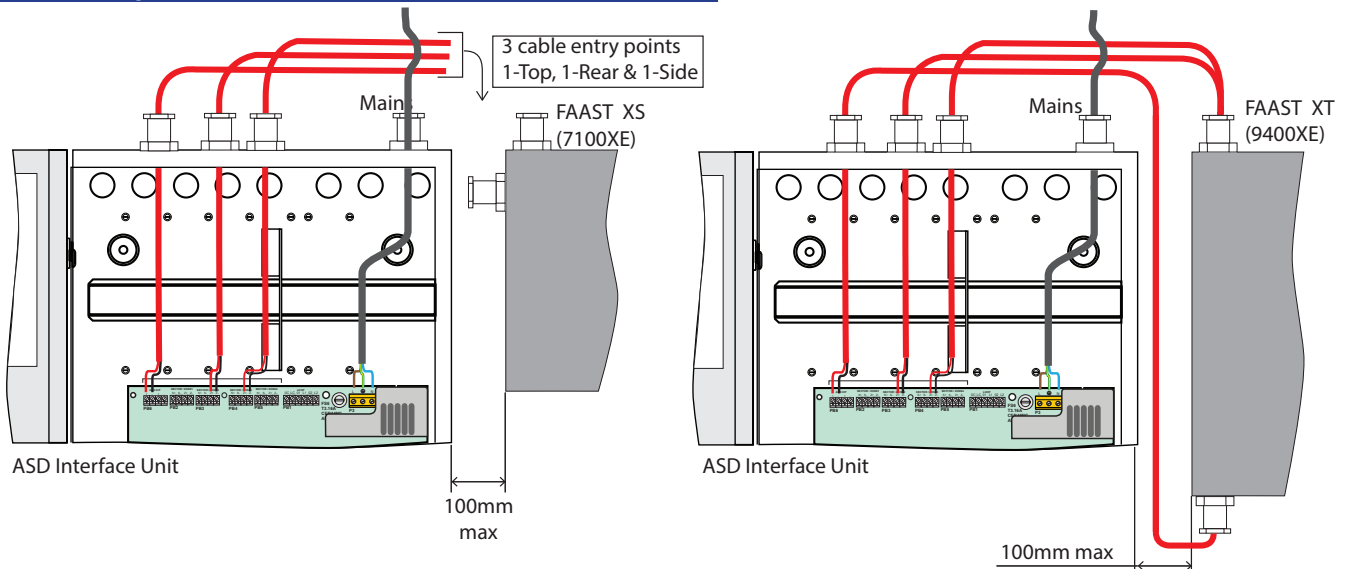

# FAAST XT (9400XE) Dual Port (2-Channel) unit installation

Wiring a FAAST XT Dual Port (2-Channel) 9400XE unit to a ASD Interface Unit (S4-34440-ASD)

**!** If a lower default threshold (% OBS / FT) is required then wire to Fire output **Fire 1 Relay contacts (T8)** instead of **Fire 2 Relay contacts (T9)**.

**!** Ensure the End-of-line devices are fitted to Zone 1 and Zone 4 at ASD interface as illustrated below.

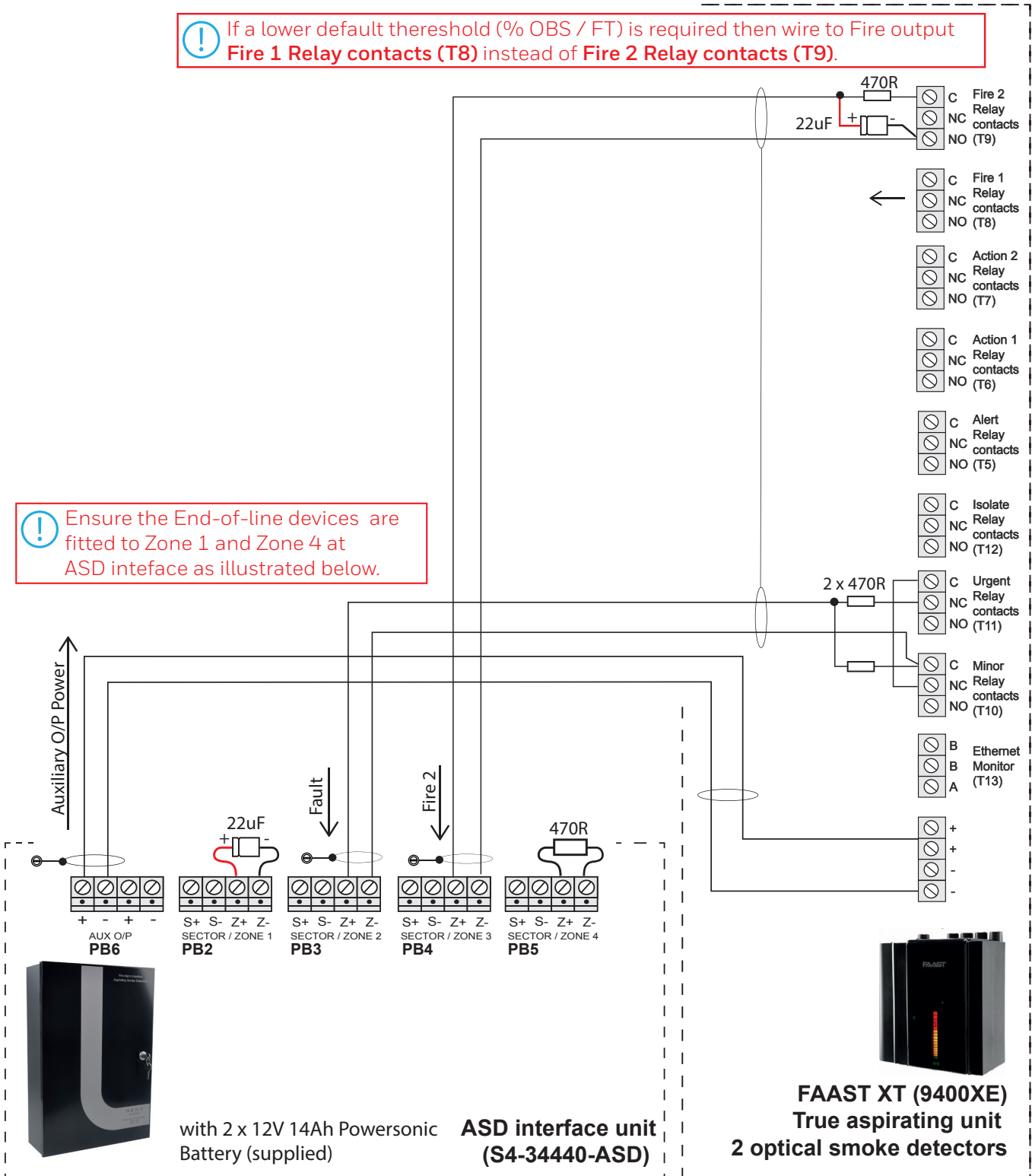

with 2 x 12V 14Ah Powersonic Battery (supplied) **ASD interface unit (S4-34440-ASD)**





**FAAST XT (9400XE)**  
True aspirating unit  
2 optical smoke detectors

© Connection to metal enclosure **Set the ASD Interface in the Vigilon system as a FAAST 8100E using Commissioning tool.**

## Commissioning

The ASD Interface unit and the FFAST unit are both configured to operate in a Vigilon system, using Vigilon Commissioning tool  $\geq$  V1.31 and FFAST Commissioning using PipelQ tool.

## Symbols on product

	Electric shock hazard.
	Protective Earth connection terminal.
	The WEEE symbol. It indicates the product is to be recycled and not thrown away.
	The CE compliance logo. This product is in conformity with the relevant European Union harmonisation legislation.
	The RoHS compliance logo. The RoHS directive restricts the use of certain hazardous substances commonly used in electronic and electronic equipment.

Notes

 **WEEE Directive:**  
 At the end of their useful life, the packaging, product and batteries should be disposed of via a suitable recycling centre.  
 Do not dispose of with your normal household waste. Do not burn.

 At the end of their useful life, the packaging, product and batteries should be disposed of via a suitable recycling centre and in accordance with national or local legislation.

 2811	
<b>Gent by Honeywell (Novar Systems Limited)</b> <b>Manufactured by: Honeywell Life Safety Systems,</b> <b>140 Waterside Road, Hamilton Industrial Park,</b> <b>Leicester, LE5 1TN, United Kingdom</b> 15	
DoP 118-CPR-2015	Product No. S4-34440-ASD
EN54-4: 1997 + A12002, A2:2006, EN54-17:2005, EN54-18:2005 S4-34440-ASD (EN54-4-17 & 18)	
<b>Intended for use in fire detection and fire alarm systems                  in and around buildings</b> Refer to DOP 118-CPR-2015 for level or class of performance declared, for details see website <a href="http://www.gent.co.uk">www.gent.co.uk</a>	

Honeywell Gent reserves the right to revise this publication from time to time and make changes to the content hereof without obligation to notify any person of such revisions of changes.

	Hamilton Industrial Park, Waterside Road, Leicester LE5 1TN, UK.		Website: <a href="http://www.gent.co.uk">www.gent.co.uk</a>
	Telephone: +44 (0) 203 409 1779	Tech. Support <a href="http://www.gentexpert.co.uk">www.gentexpert.co.uk</a>	Fax (UK) +44 (0) 116 246 2300