



## Installation instructions

Vigilon Plus 4/6 Loop Control panel  
based Fire detection and alarm system



Up to 2km  
loop

<b>Contents</b>		Batteries and Battery Box	18
Notes	4	Power supply	19
Installation	4	Panel installation	20
Second fix	4	Mounting & cable entry points	21
Fixture and fittings	4	Semi-Flush fixing the control panel	22
As fitted drawings	4	Battery box for VIG1-72 panel	23
Cable type and routing	4	19 inch Rack mounting frames	23
Fire sensor covers	4	Wiring the battery box	24
Earth continuity	5	Cable termination on enclosure	25
Power supply	5	Wiring tests	25
Mains supply	5	Mains & battery supply cables	25
Local Manual Call Point	5	Mains supply	26
EN54 information	6	Terminals for external circuits	27
Optional functions with requirements of European standard	6	Device loop circuits	28
System wiring	7	Master alarm circuits	29
Cable separation	7	Clean contacts	29
Lightning protection	7	Auxiliary relay circuits	30
Cables	8	RS232 / RS485 Communication	31
Requirements of cables	8	Connecting a Remote printer	32
Mains Supply cable	8	Network of systems	33
Repeat indicator to panel cable	8	Network connections	34
Loop cables	9	Copper network connections	34
Enhanced loop cables	9	Network wiring	34
Standard loop cables	9	Fibre network connections	35
2.5mm <sup>2</sup> Loop cable	9	Network cable screen continuity	35
Network cables	10	How to minimise cross talk	35
Enhanced Network cables	10	Domain Bridge across Networks	36
Standard Network cables	10	Methods of domain bridging	36
Loop circuit design	12	Star connection	36
Loop Card	12	Fibre Optic Domain bridge using FO Network DOM card	37
Post October 2013 Loop Card	12	RS232 Domain bridge using Domain IO card	37
Condition of use	12	Domain bridge using NPORT module	38
Battery Standby and Loop load calculator tool	12	Modem Domain bridge	39
Loop Cable length	12	On completion of wiring installation	39
Loop device load and length calculations for 2Km loop card	12	S-Quad Sensors	40
What are Lumped and Distributed alarm device loads?	13	Siting	41
Distributed alarm device load	13	Do's and Don't	41
Lumped alarm device load	13	Metal back box	42
Vigilon Loop Diagnostic tool	13	In - Out wiring to S-Quad bases	42
Typical Vigilon System	14	Programmable input/output	43
Vigilon panel	15	Tools for S-Quad	44
Features	15	Vigilon panel parts	45
Technical data	16		
Control panel	16		

## Preface

This is the second issue of the Installation instructions for the Vigilon Plus 4/6 loop panel having the 2Km loop cards.

These instructions must be read in conjunction with BS 5839 : Part 1, which is the Code of Practice for design, installation, commissioning and maintenance of systems in non-domestic premises.

## Associated Documents

Vigilon Plus panel based system - Operating instructions  
Log book

## Symbols on product



**DANGER** Electric shock hazard.



Protective Earth connection terminal.



The WEEE symbol. It indicates the product is to be recycled and not thrown away.



The CE compliance logo. This product is in conformity with the relevant European Union harmonisation legislation.

**RoHS** The RoHS compliance logo. The RoHS directive restricts the use of certain hazardous substances commonly used in electrical and electronic equipment.

## Conventions



**This is a note to highlight important text that is normally hidden in the main text.**



**This is either a caution to prevent damage to the equipment or a warning to inform of dangerous conditions that may result in injury or death.**

## Abbreviations

ac	Alternating current
dc	Direct current
EOL	End of line
ESD	Electrostatic discharge
<i>FARE</i>	<i>Fire Alarm Routing Equipment</i>
<i>FPE</i>	<i>Fire Protection Equipment</i>
I/F	Interface
IO or I/O	Input Output
IP	Ingress protection
LCD	Liquid crystal display
LED	Light emitting diode
LPCB	Loss prevention council certification board
MCC	Master control card (CARD 0)
MCP	Manual call point
MICC	Mineral insulated copper cable
N/C	Normally closed
N/O	Normally open
OC or O/C	Open circuit
PCB	Printed circuit board
PSU	Power supply unit
QB	Quick blow (fuse)
SC or S/C	Short circuit
T	Anti-surge (fuse)

## Notes

The power-up of the control panel and commissioning of the system is done by the Servicing organisation.

### Installation

It is recommended that the installer follow the general requirements of *BS 5839 : Part 1 : 2013, which is the code of practice relating to fire detection and alarm systems for buildings*. The installer must follow the relevant parts of *BS 7671 : 2008 Requirements for Electrical installations, IEE wiring regulations 17th edition* if installation is in the United Kingdom.

### Second fix

To prevent the possibility of damage or dirt degrading the performance or appearance of the products, the installation of second fix items should be delayed until all major building work in the area is complete.



**The installation of all outstanding parts and the panel power up is usually carried out during system commissioning.**

### Fixture and fittings

It is the installers responsibility to provide adequate fixtures and fittings for the type of construction surface onto which a product is to be installed, whilst utilising the fixing points on the respective product. As an aid to this decision, the weight and overall size of each full assembly together with implications on cable entries and routing should be taken into consideration.



**All these procedures assume that the cable, gland, steel box (BESA box) and other related accessories are provided by the installer.**

### As fitted drawings

The installer should acquire site specific information from the interested parties, for details on the location of products for installation. The acquired information together with this guide and the relevant standards should be used to assist the work.

Each product assembly can be identified from its package label. The contents of all packages should be checked for any discrepancies.

### Cable type and routing

Appropriate attention must be given to ensure the correct cable type is installed in accordance with 'as fitted drawings', site specific information and recommendations of *BS 5839 Part 1 : 2013*. The cables must be installed using cable manufacturers recommended fixing and accessories.

### Fire sensor covers

Each fire sensor may be supplied with a plastic dust cover. If supplied, the cover must be fitted to prevent dust and dirt from the building work contaminating the fire sensor.

## Earth continuity

All earth connection points should be clean to provide a good electrical conductivity path. To maintain the earth continuity: all earth leads and fittings provided should be installed. The loop cable screen must be continued through each system device on the loop circuit, whether the earth is connected to the device or not.



**Do not use any part of building structure for earthing.**

Some of the system products having metal enclosures have a zinc coating around the cable termination points, the coating provides a good electrical conductivity path for cable earth termination. The zinc coating on metal enclosures should not be damaged. Any damage will expose bare metal, which can corrode and make a poor earth connection.

## Power supply

The power to the system is derived from the mains and battery supplies. Before removal of a card or disconnection of cable from the panel ensure both mains and battery supplies are disconnected.

## Mains supply

Mains supply to any fire alarm control and indicating equipment must be via an unswitched 5A fused spur unit. A disconnect device must be provided to disconnect both poles and must have a minimum gap of 3mm. The disconnect device should be available as part of the building installation and must be easily accessible after installation is complete.



**All mains powered equipment must be earthed.**

## Local Manual Call Point

To comply with the requirements of EN54 : Part 2 : 1997 a conventional manual call point must be installed near the main control panel. The call point must be wired to an input line of an interface unit on the loop circuit. During commissioning call point input must be set up to evacuate all sectors without delay.



**Failure to install and configure a local manual call point in the manner described above when delays are set up on the system will result in the panel not complying to EN54-2 : 1997.**

---

## EN54 information

### Optional functions with requirements of European standard

The Control panel complies with the requirements of *EN54-2 : 1997*. In addition to the basic requirements of the standard the panel conforms to the following optional clauses:

Clause	Description
7.8	Output to fire alarm devices
7.9	Control of Fire Alarm Routing Equipment FARE (options with requirements) sub clause: 7.9.1 Output to FARE
7.10	Output to Fire Protection Equipment FPE (options with requirements) sub clause: 7.10.1 Output Type A
7.11	Delays to action outputs
7.12	Dependencies on more than one alarm signal (options with requirements) sub clause: 7.12.3 Type C dependency
8.3	Fault signals from point
9.5	Disablement of each addressable point
10	Test condition

## System wiring

If instructed, the installer may need to terminate as well as connect the cables to the appropriate terminal blocks.

### Cable separation

Where the outgoing and return cables of a loop circuit covers more than the equivalent of one zone they must not run together, for example, either close to the Control Panel or in a service duct. There should be as much physical separation as possible between the cables and the mechanical protection of the cable should be to a particularly high standard. This is to minimise the risk of accidental damage to both cables.

### Lightning protection

Where a loop cable is mounted to an external wall or between two buildings then consideration should be given to the use of lightning protection devices.

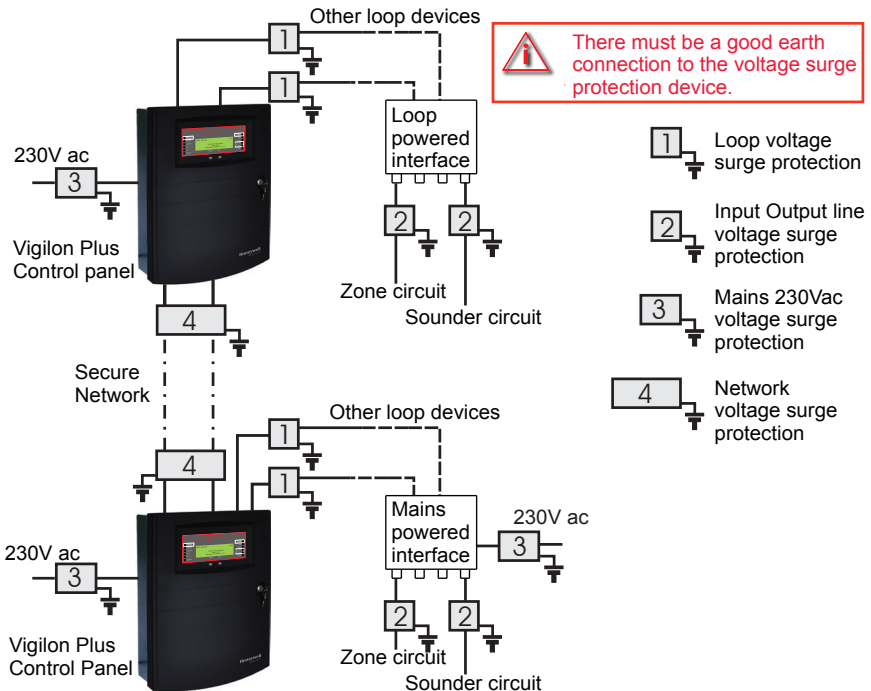

## Cables

### Requirements of cables

The British Standard

BS 5839 Part 1 : 2013 Code of practice for system design, installation, commissioning and maintenance states the requirements for standard and fire resisting cables in Clause 26.2 section d & e. "d) Standard fire resisting cables should meet PH 30 classification when tested in accordance with EN50200 and maintain circuit integrity if exposed to the following test:

- a sample of the cable is simultaneously exposed to flame at a temperature of 830°C - 0+40°C and mechanical shock for 15min, followed by simultaneous exposure to water spray and mechanical shock for a further 15min.

e) Enhanced fire resisting cables should meet the PH120 classification when tested in accordance with EN 50200 and maintain circuit integrity if exposed to the following test:

- a single sample of the cable is simultaneously exposed to flame at a temperature of 930°C - 0+40°C and mechanical shock for a period of 60min, followed by simultaneous exposure to water spray and mechanical shock for a further 60min."

**The cables listed in this manual are those that have been tested/assessed for EMC compliance with the system products.**

### Mains Supply cable

The mains supply cable must be a standard fire resisting type and should meet PH30 classification, such as standard or enhanced cable.

### Non-Functional Repeat indicator to panel cable

A maximum of 1Km cable distance is allowed between Control Panel and Repeat indicator panel

- Belden No. 9842 EIA RS485 Applications, O/A Beldfoil® Braid having two twisted pairs

### Cables no longer available

- ☒ A cross bullet point mark show a cable that may no longer be commercially available. Such a cable if already installed in a building may be suitable for reuse where a site is being refurbished, consult with your electrical installer.

## Loop cables



**There is a maximum limit of 2Km loop cable usage allowed per loop circuit. This maximum limit is the sum of the cable used on main loop circuit, spurs off main loop circuit, plus cable runs to all input / output lines off loop powered interface units installed on the same loop.**

**There is a further maximum limit of 100m cable run allowed per input/output line off loop powered interface unit.**

The device loop cable carries both data and power, therefore its selection is important. Note the following:

- In countries where the European EMC directive is in force, only EMC Compliant cables are to be used.
- The loop cable usage must not exceed 2Km. This includes the cable used on main loop and spur circuits.
- Single pair cable must be used. It is NOT permissible to run mixed loops or outgoing and return pairs in a multi core cable, due to inadequate separation and possible electrical interference problems.
- Each core of the loop cable must be 1.5mm<sup>2</sup> cross section area.
- the cable screen must be capable of being earthed at each system device (outstation).
- Red is the preferred cover sheath for fire applications.
- The specified loop circuit cables are also suitable for wiring master alarm, auxiliary relay, input/output lines and mains supply.

## Enhanced loop cables

Approved cables for loop wiring (EMC Compliant)

- Draka Firetuf FT120 Enhanced - **FTPLUS2EH1.5RD** (formally Firetuf **FT Plus**)
- Datwyler Pyrofil Enhanced
- Mineral insulated cable (MICC) to BS6207:Part 1
- Prysmian (formally Pirelli) **FP PLUS \***

## Standard loop cables

Approved cables for loop wiring (EMC Compliant)

- AEI Cables **FIRETEC \***
- ☒ Alcatel cable **PYROLON E \*** distributed by Winstonlead
- ☒ BICC Pyrotex **FLAMESIL FRC \***
- Cavicel SpA **FIRECEL SR 114H \*** distributed by Cables Britain
- Datwyler Pyrofil Standard \* (previously **LIFELINE**)
- Draka Firetuf EMC Standard 1.5mm<sup>2</sup> **FTEMC2EH1.5RDR**
- Draka Firetuf **FTES2EH1.5** (previously **FTZ2E1.5 FIRETUF OHLS \***) fire resistant data cable
- Huber & Suhner **RADOX FR \***
- Prysmian (formally Pirelli) **FP200 FLEX \***
- Prysmian (formally Pirelli) **FP200 GOLD \***
- Raydex **CDT FG950 \***

## 2.5mm<sup>2</sup> Loop cable (2.5Km loop)



**The cable reference for a 2.5mm<sup>2</sup> loop cable is similar to 1.5mm<sup>2</sup> cable, for example the cable reference for a Draka Firetuf 1.5mm<sup>2</sup> is FTPLUS2EH1.5 and for a 2.5mm<sup>2</sup> it is FTPLUS2EH2.5, consult cable supplier.**

For cables marked with an \* see note on the next page.



**The cables marked \* utilise laminated aluminium tape with a tinned drain wire for electrostatic screening. Under certain environmental conditions galvanic action may take place between the aluminium and the drain wire. This will severely degrade EMC performance as the foil to drain wire impedance will increase. Armoured variants of these can also be used for wiring a loop circuit.**

### Cables no longer available

- ☒ A cross bullet point mark show a cable that may no longer be commercially available. Such a cable if already installed in a building may be suitable for reuse where a site is being refurbished, consult with your electrical installer.

## Network cables

### Enhanced Network cables

Approved cables for network wiring (EMC Compliant)

- ▣ Draka Firetuf FT120 Enhanced FTPLUS3EH1.5 (Previously Firetuf FT Plus) 1.2Km maximum Panel to Panel or Panel to Network node cable distance
  - 3 Cores, each having 1.5mm<sup>2</sup> cross section area
- ☒ Fireshield **Enhanced FSN G2000** 1.2Km maximum Panel to Panel or Panel to Network node cable distance
  - 3 Cores (1 pair + 1) and earth
  - each core having 1mm<sup>2</sup> cross section area

- ▣ **Mineral insulated copper cable** 800m maximum Panel to Panel or Panel to Network node cable distance.
  - BS6207: Part 1
  - 3 parallel cores
  - having continuous metal sheath encapsulating
  - each core having 1.5mm<sup>2</sup> cross section area
  - a red cover sheath (preferred for alarm applications)
- ▣ Prysmian (formally Pirelli) **FP Plus\*** 1.2Km maximum Panel to Panel or Panel to Network node cable distance
  - 3 Cores each having 1.5mm<sup>2</sup> cross section area

### Standard Network cables

Approved cables for network wiring (EMC Compliant)

- ▣ **Belden Armoured equivalent** This cable being a two pair cable to BS5308:Part 1 (type 2) 0.5mm<sup>2</sup> (16/0.2mm). 600m maximum Panel to Panel or Panel to Network node cable distance.
- ▣ **Belden No 9729** (UL Style 2493) 1.2Km maximum Panel to Panel or Panel to Network node cable distance
  - 2 twisted pairs
  - Each pair individually screened 24AWG (7 strands x 32 AWG)
  - Capacitance between conductors 39.4pF/m at 1kHz
  - Capacitance conductor to screen 72.2pF/m at 1kHz
  - Temperature range -30°C to +60°C
- ▣ **Belden No. 9842** EIA RS485 Applications, O/A Beldfoil® Braid 1.2Km maximum Panel to Panel or Panel to Network node cable distance Must have following characteristics:
  - 2 twisted pairs
  - 24AWG (7 strands x 32 AWG)

- conductors (1KHz)
  - Characteristic impedance - 120ohms
  - Capacitance between conductors - 42pF/m at 1kHz
  - Capacitance conductor to screen - 75.5pF/m at 1kHz
  - Capacitance - conductors 110pF/m (1KHz)
  - Capacitance - screen to core 210pF/m (1KHz)
  - Fire resistance tested to BS6387 category CWZ and IEC 331.
- ▣ **Belden TR No. 89729**  
(Teflon jacketed)  
1.2Km maximum Panel to Panel or Panel to Network node cable distance
- 2 twisted pairs
  - Each pair individually screened 24AWG (7 strands x 32 AWG)
  - Capacitance between conductors 39.4pF/m at 1kHz
  - Capacitance - conductor to screen 72.2pF/m at 1kHz
  - Temperature range up to 200°C
- ☒ **Datwyler PYROFIL 8750-U/R\***  
1.2Km maximum Panel to Panel or Panel to Network node cable distance
- 4 cores
  - each core having 1.5mm<sup>2</sup> cross section area
- ☒ **Delta Crompton Firetuf FDZ1000\***  
1.2Km maximum Panel to Panel or Panel to Network node cable distance
- 3 cores
- ▣ **Doncaster Cables Firesure Plus\***  
1.2Km maximum Panel to Panel or Panel to Network node cable distance
- 4 Cores (2- pair plus earth)
  - each core having 1.5mm<sup>2</sup> cross section area
- ▣ **Huber & Schner Radox series FR**  
communication cable\*  
1.2Km maximum Panel to Panel or Panel to Network node cable distance
- 3 cores twisted triad screened
  - 1.5mm<sup>2</sup> (7/0.42 stranded) conductors
  - Nominal impedance 200 ohms
- ▣ **Prysmian (formally Pirelli) FP200 Flex\***  
800m maximum Panel to Panel or Panel to Network node cable distance
- 3 Cores, each having 1.5mm<sup>2</sup> cross section area
- ▣ **Prysmian (formally Pirelli) FP200 Gold\***  
1.2Km maximum Panel to Panel or Panel to Network node cable distance
- 3 Cores
  - each core having 1.5mm<sup>2</sup> cross section area
- ▣ **Prysmian (formally Pirelli) FP 400 Armoured**  
800m maximum Panel to Panel or Panel to Network node cable distance
- 4 Cores, each stranded 1.5mm<sup>2</sup> cross section area

## Loop circuit design



**It is important that redundancy is built into the system to accommodate for future expansions and change of area usage in the protected premises.**

The number of devices on a loop circuit can be limited by the total number of addresses available, the electrical load on the circuit, the maximum cable length and other geographical considerations.

- A loop circuit must not cover more than 10,000m<sup>2</sup> of floor area of a protected site
- In total a maximum of 200 devices are allowed per loop circuit.

## Loop Card

The panel is supplied with one Post March 2014 Loop Card (VIG-LPC-EN). If more than one loop is required then acquire additional cards for each additional loop.

### Condition of use



**The Loop Card (VIG-LPC-EN) must never be fitted as a replacement card in a Vigilon panel where 3400 devices are installed on its loop circuits.**

- Up to 2Km loop length is possible with S4 and S3 Mark 2 devices installed on a loop circuit. In this case a rough method for calculating the loop load and loop cable length is shown in the leaflet for the loop card. For a precise loop load and battery standby calculation use the 'Battery Standby and Loop load calculator' tool.
- Up to 1Km loop length is possible with 34000 devices or a mix of 34000, S4 and S3 devices installed on a loop circuit. Again for precise loop load and battery standby calculation use the 'Battery Standby and Loop load calculator' tool.

### Battery Standby and Loop load calculator tool

The 'Battery standby and loop load calculator' tool can be downloaded from [www.gentexpert.co.uk](http://www.gentexpert.co.uk) website by registered users.

### Loop Cable length



The loop cable length is defined as the sum of the length of cable used on the main loop plus that used on all the spur circuits off the main loop having system devices.

### Loop device load and length calculations for 2Km loop card

There can be up to 200 devices on a loop cable of up to 2Km length when using Loop Card (VIG-LPC-EN), where both device count and cable length are dictated by the number of alarm devices on the loop and how they are positioned, distributed or lumped together.

## What are Lumped and Distributed alarm device loads?

### Example of Lumped alarm device load



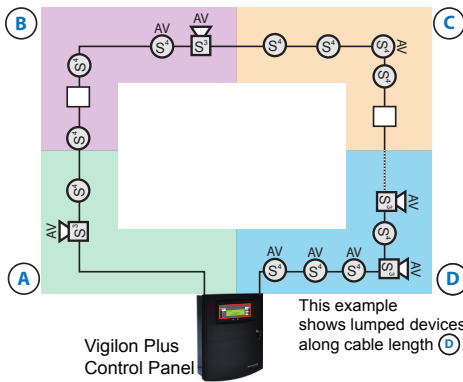

Where 35% of the alarm devices   are lumped together in 1/4 segment **A**, **B**, **C** or **D** of a loop.

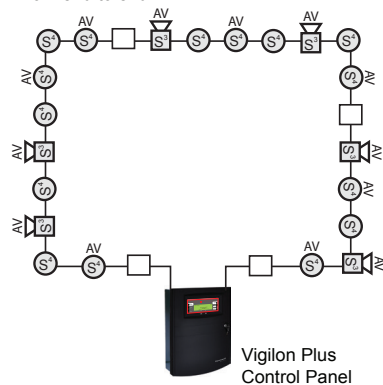

### Example of Distributed alarm device load

Distributed alarm devices   are evenly spaced along the entire length of the loop cable from end to end.



key:   - Audio Visual S4 and S3 devices	 - S4 Sensor only devices	 - Other system devices
---	--	--

### Distributed alarm device load

Where the alarm load is distributed along the entire length of the loop using:

- 1.5mm<sup>2</sup> cable, the loop length can be up to 2Km with up to 200 devices
- 2.5mm<sup>2</sup> cable, the loop length can be up to 2.5Km with up to 200 devices.

### Lumped alarm device load

If the alarm devices are lumped together on a loop circuit then there is a trade off between the number of alarm devices and loop cable length possible, see also loop card leaflet which can be downloaded by registered users from [www.gentexpert.co.uk](http://www.gentexpert.co.uk).

### Vigilon Loop Diagnostic tool

The Vigilant Loop Diagnostic Tool can be used to diagnose loop circuits driven by Post March 2014 Loop Cards (VIG-LPC-EN) fitted in the panel.

## Typical Vigilon System

The loop allows wiring of addressable devices like **fire sensors, alarm sounders, call points, interface units, mimic and repeat panels**, a combined maximum of up to **200** devices are allowed per loop circuit, a further limit on a loop circuit is determined by device loading.

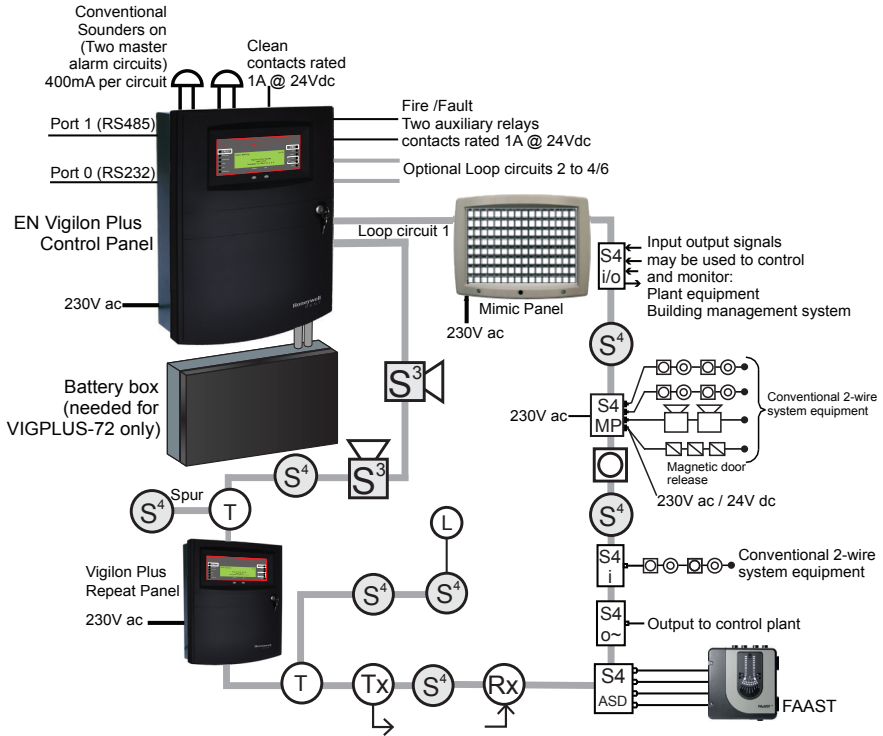

### Addressable System Devices

- S-Quad Sensor Speech Sounder & VAD/Strobe
- S-Cubed Voice enhanced Speech, Sounder, VAD/Strobe Unit
- Manual Call Point
- T Breaker
- Beam sensor Transmitter and receiver
- Beam sensor Transmitter and receiver

- S4 4-Input/Output loop powered interface
- S4 1-Input loop powered interface
- S4 1-Output + Confirmation input loop powered interface
- S4 Mains switching output loop powered interface
- S4 - Input/Output mains powered interface unit
- S4 - Input/Output ASD interface unit

### Conventional Products off interface inputs

- Magnetic door release
- Alarm sounder
- Conventional Fire Detector
- Manual Call Point
- End of Line Unit

### LED off S4 sensor

- Remote LED

## Vigilon Plus panel



The Vigilant Plus panels (VIGPLUS-24 or VIGPLUS-72) are analogue addressable fire alarm panels designed to the requirements of *EN54-2 : 1997 and EN54-4 : 1997*

The panels can accommodate up to 4 or 6 loop circuits for the connection of Vigilant Plus range of analogue and addressable devices. The panels have integral mains derived power supply. The VIGPLUS-24 panel has integral batteries and the VIGPLUS-72 panel has batteries fitted in a separate enclosure for extended standby supply. The batteries supply standby power in the event of mains power failure. A lockable front door prevents unauthorised access to fire alarm controls but allows all of the indicators to be seen. The panels have integral zonal indicators to provide zone fire or fault indications. Two push button controls are located on the front door below the display that enable Fire messages to be scrolled in the event of multiple fires. The panels are designed for surface or semi-flush mounting with rear and top cable entry points.

### Features

- Analogue addressable fire detection and alarm control
- Supports up to four or six loop circuits per panel
- Up to 200 addressable devices can be connected to a loop circuit. Devices like sensors, MCPs and interface units etc.
- Two master alarm circuits
- Optional RS485 to connect to a Repeat Indicator panel
- Optional RS232 to connect to another control panel (domain bridge) or external printer
- USB for commissioning tool connection
- SD card for configuration and events log.
- Two sets of auxiliary relay change over contacts configurable to operate with fire, fault or disablement event
- One set of clean voltage-free change over contacts that operates with fire events
- Standby supply to power the system during mains failure
- LCD alphanumeric display with back light to show event information
- Integral 32 zone LED indicators (with First fire steady / flashing or disable integral zone indication's options)
- LED lights for event indication
- Local buzzer gives audible sound to announce events
- Push button for essential controls and menu options
- Four programmable control buttons (U1 to U4)
- Fire Alarm Routing Active and Fault/Disable LED indications
- A remote battery box (for VIGPLUS-72 panel only)

**Technical data**

**Control panel**

<i>Standard</i>	<i>Designed to EN54-2:1997 + A1:2006 (and include optional clauses 7.8, 7.9, 7.9.1, 7.10, 7.10.1, 7.11, 7.12.3, 8.3, 9.5 and 10)</i>
<i>Approval</i>	<i>LPCB approval pending</i>
<i>Panel dimensions in mm with outer door</i>	<i>height 543 x width 406 x depth 172</i>
<i>Panel weight</i>	
<i>VIGPLUS-24</i>	<i>10.2Kg approximately + 2 batteries 12V 21Ah battery - weight 6Kg each</i>
<i>VIGPLUS1-72</i>	<i>10.2Kg</i>
<i>Battery box#</i>	<i>7.2Kg</i>
<i># with 4 batteries</i>	<i>31.2Kg</i>
<i># with 8 batteries</i>	<i>55.2Kg</i>
<i>Storage temperature</i>	<i>-10°C to +55°C</i>
<i>Operating temperature</i>	<i>-5°C to +40°C</i>
<i>Relative Humidity</i>	<i>up to 90% (Non condensing) Temperature +5°C to +40°C</i>
<i>Emission</i>	<i>BS EN 6100-6-3 : 2001 Residential, Commercial &amp; Light Industry Class B limits</i>
<i>Immunity</i>	<i>BS EN50130-4 : 1996 Alarm systems: Electromagnetic compatibility Product family standard: Immunity requirements for components of fire, intruder and social alarm systems</i>
<i>Ingress Protection</i>	<i>IP30</i>
<i>Colour</i>	<i>Door: HONEYWELL GREY 90 PMS BLACK C Backbox: HONEYWELL GREY 90 PMS BLACK C</i>
<i>Loops</i>	<i>The panel is supplied with a loop card for 1 loop circuit. It can support up to 4/6 Loop circuits, using optional loop cards.</i>
<i>Network</i>	<i>Two types of network cards are available for secure network connection: Fibre Optics - 2Km maximum Copper (RS485) - 1.2Km maximum</i>
<i>RS232 and RS485 connections</i>	<i>The panel will require an optional IO Card to facilitate RS232 for connections for domain bridging and remote printer. The maximum cable length allowed for RS232 is 15m. The panel has an RS485 port to accept the Repeat Indicator panels. The Commissioning tool can be connected to the panel via the USB port on the Master Control Card.</i>
<i>Devices per loop</i>	<i>A maximum of 200 addressable devices per loop circuit.</i>
<i>Device labels</i>	<i>Each device can be given a 32 character label for identification. Each MCP is restricted to 28 character label. Potentially up to 72 character label is possible depending on choice of words, tokenised words can lengthen the label.</i>

<p><i>Plug in Card slots</i></p> <p>MCC / LCC -P1</p> <p>IOC / N/W -P2</p> <p>Loop 1 - P3</p> <p>Loop 2 - P4</p> <p>Loop 3 - P5</p> <p>Loop 4 - P6</p> <p>Loop 5#, IOC / N/W-P7</p> <p>Loop 6#, IOC / N/W -P8</p>	<p>Master Control card - supplied</p> <p>Input Output card / Network card option</p> <p>Loop card - supplied</p> <p>Loop card option</p> <p>Loop card option</p> <p>Loop card option</p> <p>Loop card#, Input Output card or Network card option</p> <p>Loop card#, Input Output card or Network card option</p> <p># - for VIGPLUS-72 only</p>
<p><i>Clean contacts</i></p>	<p>1 set of voltage free change over contacts rated 1A @ 24Vdc, active with master alarms</p>
<p><i>Auxiliary relays</i></p> <p>Aux relay 1</p> <p>Aux relay 2</p>	<p>Voltage-free contacts rated 1A @ 24Vdc,</p> <p>2 sets of change over contacts configured to operate immediately on a Fire event. The relay is normally de-energised</p> <p>2 set of change over contacts configured to operate immediately on a Fault event. The relay is normally energised</p> <p>The relays can be re-configured to operate with Fire, Fault or Disablement event, with a maximum delay of up to 10 minutes and can operate in a normally energised or de-energised state.</p>
<p><i>Master alarm circuits voltage and current, protection fuses</i></p>	<p>2 - (24 volts nominal)</p> <p>400 mA max per circuit</p> <p>MA1 - fuse 1A FS1</p> <p>MA2 - fuse 1A FS2</p> <p>(20 x 5mm) on Terminal card.</p>
<p><i>RS232 and RS485 connections</i></p>	<p>The panel will require an optional standard IO Card to facilitate RS232 for connections for domain bridging and remote printer. The maximum cable length allowed for RS232 is 15m.</p> <p>The panel has an RS485 port to accept the Repeat Indicator panels. The Commissioning tool can be connected to the panel via the USB port on the Master Control Card.</p>
<p><i>Display</i></p>	<p>Display - 8 lines by 40 character per line, back-lit, (Black characters on green background, liquid crystal display)</p>
<p><i>Internal buzzer</i></p>	<p>Announces Fire &amp; Fault events, plus give key-press confirmation beep.</p>
<p><i>Indicators</i></p>	<p>Fire (red), 32 Zones (red) hidden till lit, Verify (amber), FARE Active (red), FARE Fault/Dis (amber), Power (green), Fault (amber), Disablement (amber), System fault (amber), Power fault (amber), Sounder (amber), Test (amber) and Delay (amber)</p>
<p><i>Controls (with door closed) Access level 1</i></p>	<p>Next and Previous buttons operable during Fire condition only</p>
<p><i>Controls (with door open) Access level 2a</i></p>	<p>Sound Alarms, Silence Alarms, Reset, Cancel Buzzer, Verify, F1-F4 keys, Menu On/Off key, QWERTY key board, U1-U4 keys available if configured to perform site specific actions by triggering of command builds 251, 252, 253 and 254.</p>

Access level 2b	Customer (Customer PIN) Access as level 2a plus access to complete level 2 menu commands.
Access level 3	Engineering (Engineers PIN) Access as level 2b plus access to all level 3 menu commands.
Menus	[Control], [Setup], [Information] and [Test Engineering] menus.
Logs	<b>Active Logs:</b> Fire, Fault and Disablement <b>Historic log:</b> All events <b>Event logs:</b> Fault, Disablement, Warning, Supervisory, Exceptions and Historic fires. (up to 255 events) <b>Fire Log</b> (up to 100 events)
Printer	The integral printer if fitted operates when the outer door is open. The 'printer menu' include: ON, OFF, Line feed and Test print controls. An optional remote printer can be connected to the panel.

### Batteries and Battery Box

The batteries provide 24/72 hour standby supply plus power to alarm load for 30 minutes. The 'Battery Standby and Loop Load Calculator' tool can be used to determine the load on the loop to achieve the standby power in the event of mains failure. The battery box is only used with the VIGPLUS-72 panel and can be installed in a remote location up to 10m cable distance away from the control panel when using 1.5mm<sup>2</sup> MICC. When using 2.5mm<sup>2</sup> MICC then the cable length can be increased to 15m.

Battery box dimensions in mm	height 437 x width 421 x depth 174				
Terminals	Accept cable size of up to 2.5mm <sup>2</sup>				
Battery box weight (including batteries)	31.2Kg with 4 batteries 55.2Kg with 8 batteries 1 x 12V 21Ah battery weight is 6Kg				
Battery	<table border="0"> <tr> <td style="vertical-align: top;">VIGPLUS-24</td> <td>Batteries installed in the panel 2 x Powersonic 12V 21Ahr - (supplied) Model number PG12V21 B</td> </tr> <tr> <td style="vertical-align: top;">VIGPLUS-72</td> <td>Batteries installed in a battery box 4 x Powersonic 12V 21Ahr - (supplied) Model number PG12V21 B The battery box can optionally accommodate up to 8 x Powersonic 12V 21Ah</td> </tr> </table>	VIGPLUS-24	Batteries installed in the panel 2 x Powersonic 12V 21Ahr - (supplied) Model number PG12V21 B	VIGPLUS-72	Batteries installed in a battery box 4 x Powersonic 12V 21Ahr - (supplied) Model number PG12V21 B The battery box can optionally accommodate up to 8 x Powersonic 12V 21Ah
VIGPLUS-24	Batteries installed in the panel 2 x Powersonic 12V 21Ahr - (supplied) Model number PG12V21 B				
VIGPLUS-72	Batteries installed in a battery box 4 x Powersonic 12V 21Ahr - (supplied) Model number PG12V21 B The battery box can optionally accommodate up to 8 x Powersonic 12V 21Ah				
Temperature monitoring	Inside the VIGPLUS-24 panel and in the battery box for VIGPLUS-72 panel - for automatic adjustment of battery charge voltage with change in temperature.				



**Always use the recommended replacement batteries, as there is a risk of an explosion if incorrect battery is used. Dispose of used batteries according to the manufacturer's instructions.**

## Power supply

Standard	Designed to EN54-4 : 1997 + A1:2002 and A2:2006
Mains supply voltage and fuses	230V -15% +10% 50Hz/60Hz protected by: FS3 T3.15AH250V Ceramic (20 x 5 mm) on PSU Input current - 1.4A
Nominal supply voltage for master alarm circuits	24V +1V, -4V
Battery circuit(s)	Terminals to connect to internally or externally housed batteries. Batteries reach fully charged state in 72Hr for VIGPLUS-24 and VIGPLUS-72.
Battery current with mains disconnected	VIGPLUS-24 - 6.2A max. VIGPLUS-72 - 6.2A max. over two battery sets
Light indications	To show the status of PSU
PSU Fuses	Mains FS6 T3.15A Ceramic 44V supply FS2 F3.15A Glass Battery charge circuit 1 FS1 F10A Ceramic for VIGPLUS-72 only FS7 F6.3A Ceramic Quick Blow for VIGPLUS-24 only Battery charge circuit 2 FS3 F10A Ceramic for VIGPLUS-72 only All fuses 20mm x 5mm size
Storage temperature	-10°C to +55°C
Operating temperature	-5°C to +40°C
Relative Humidity	up to 90% (Non condensing) Temperature +5°C to +45°C
Indicators	<b>LD1 - LD5</b> indicate RAM, ROM and EPROM status, error, checksum and communication
Battery Charging current	1 x 2.4A nominal for VIGPLUS-24 2 x 3.6A nominal for VIGPLUS-72
EN54 Part 4 data	<p><i>I</i> min -&gt; 780uA</p> <p>VIGPLUS-24  <i>I</i> max a* - max quiescent loop current -&gt; 108mA @ 43.5V  <i>I</i> max b - max alarm loop current -&gt; 3.15A @ 46.4V  <i>R</i>i max -&gt; 0.9R  UVLO -&gt; 20.7V ± 0.4V</p> <p>VIGPLUS-72  <i>I</i> min -&gt; 780uA  <i>I</i> max a* - max quiescent loop current -&gt; 162mA @ 43.5V  <i>I</i> max b - max alarm loop current -&gt; 3.15A @ 46.4V  <i>R</i>i max -&gt; 1.25R  UVLO -&gt; 20.7V ± 0.4V</p> <p>*max a - Max loop current  27mA x 6 = 162mA quiescent for VIGPLUS-72 panel  27mA x 4 = 108mA quiescent for VIGPLUS-24 panel</p> <p>Primary DC Output Voltage 43V ± 5%  ripple Voltage (peak to peak) &lt;1%</p>

















**After panel power down hazardous voltages may still be present even when the indicators are extinguished.**

## Panel installation

A VIGPLUS-24 and VIGPLUS-72 panels include the following parts:

- Back box assembly with PSU
- Inner door
- Moulded outer door
- Loop Card (1- loop card supplied), up to 4 maximum in a VIGPLUS-24 panel and up to 6 maximum in a VIGPLUS-72 panel
- Main Controller Card for VIGPLUS-24 or VIGPLUS-72 panel
- VIGPLUS-24 is supplied with 2x12V 21Ah batteries  
VIGPLUS-72 is supplied with 4x12V 21Ah batteries for installation inside a battery box (the battery box can hold up to 8 x 12V 21Ah batteries maximum)
- A Battery box is supplied with VIGPLUS-72 panel only

Parts supplied in spares packs:

Part	Qty - VIGPLUS-24	Qty - VIGPLUS-72	Battery box
 Cable tie	3	3	
 Ferrite core	1	1	
 22K 0.5W Resistor	2	2	
 Battery lead	1		
 Spade tag	2		
 Link lead	1		
 Battery lead fused			4
 Instructions	1	1	1
 20 x 5mm Fuse 6.3A QB Ceramic	1		
 20 x 5mm Fuse 3.15A AS Ceramic	1	1	
 20 x 5mm Fuse 3.15A AS Glass	1	1	
 20 x 5mm Fuse 10A QB Ceramic		2	4
 Terminal block			1
 Adhesive backed foam pad	1	1	

Each battery pair of 2 x 12V 21Ah is supplied with:

-  4 x bolts
  4 x washers
  4 x spring washers

## Mounting & cable entry points

These instructions cover installation of the panel and battery box. The cards and batteries are installed during the commissioning of the system by the servicing organisation.

The control panel can be surface or semi-flush mounted. The only time it should not be semi-flush mounted is when the battery box is close fitted beneath the control panel.

**Any unused knockouts that have been removed must not be left open.**

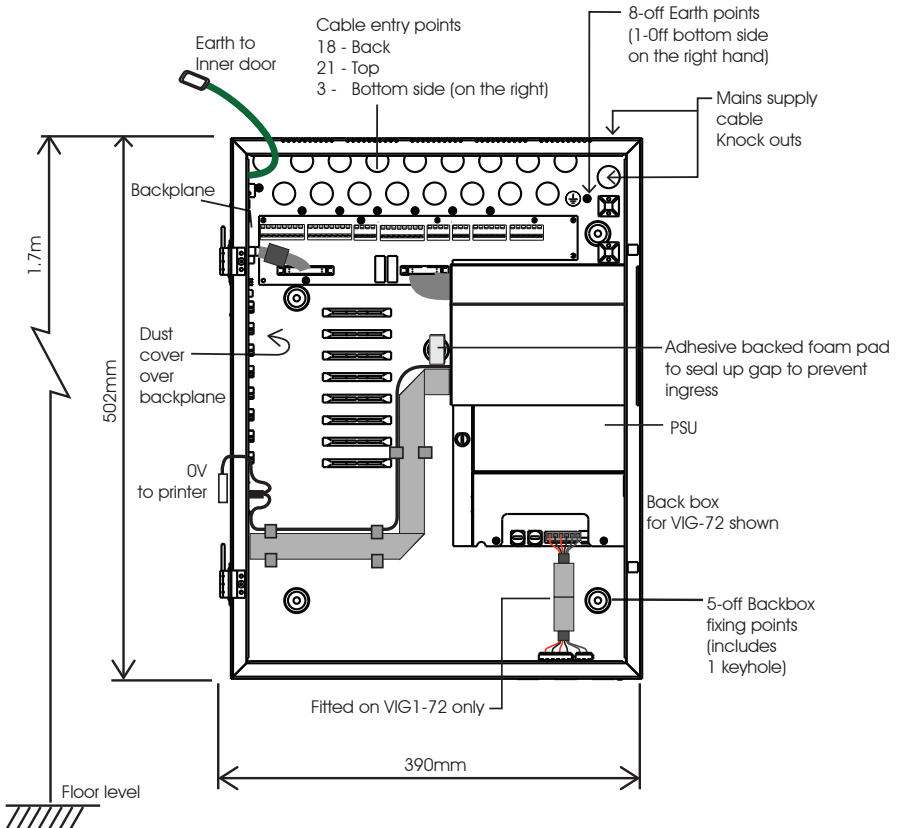

- Identify the package VIGPLUS-24 / VIGPLUS-72 and check that it contains all the parts.
- Remove the temporary cover from the Back box.
- Knock out/in the required cable entry points from the Control panel back box and from the Battery box.
- Use the fixing points provided to mount the Back box and Battery box to the wall using suitable fixings.



**The fixings must support a fully assembled Control panel and Battery box. The VIGPLUS-24 panel with batteries weigh 22.2Kg and the VIGPLUS-72 panel weigh 10.2Kg. The batteries for a VIGPLUS-72 panel are mounted in an external battery box weighing either 31.2Kg (4 batteries) or 55.2Kg (8 batteries).**

- e. Stick the adhesive backed foam pad supplied to cover gaps around the centre key-hole fixing point in the back box. This is done to seal any gaps to prevent ingress.
- f. Terminate each cable at the entry point leaving 400mm tail wire length and mark each core to identify its final connecting point.



**Where mains cable is to remain disconnected, its tail ends must be insulated to prevent dangerous conditions arising in the event of accidental switching On of the mains supply.**

### Semi-Flush fixing the control panel

The control panel may be semi-flush mounted using a semi-flush surround (VIG-24-FLUSH). A stainless steel variant of the semi-flush surround (VIG-FLUSH-SS) will require a stainless steel door (VIG\_DOOR\_SS).

- a. Check the contents of the semi-flush surround package.
- b. Cut out an aperture in the wall to allow the semi-flush surround to be fitted, see the diagram below for dimensions of the aperture in the wall.
- c. Using the fixing holes on the surround secure it into the aperture side walls.
- d. Knock out the appropriate top or rear cable points on the control panel back box.
- e. Route the cables through the cable entry points into the back box and at the same time insert the back box into the semi-flush surround.
- f. Fit the back box to the semi-flush surround using the 5 - 5mm fixing-screws supplied in the spares pack.

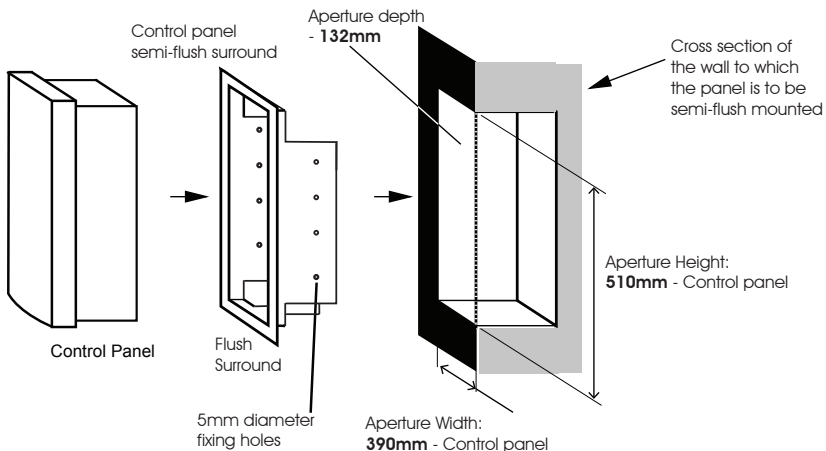

## Battery box for VIGPLUS-72 panel

The connecting battery cables from the control panel to the battery box can be either 1.5mm<sup>2</sup> or 2.5mm<sup>2</sup>.

The battery box can be mounted beneath the control panel or in a remote location. The battery box can be up to 10m cable distance away using 1.5mm<sup>2</sup> cable or 15m cable distance using 2.5mm<sup>2</sup> cable.

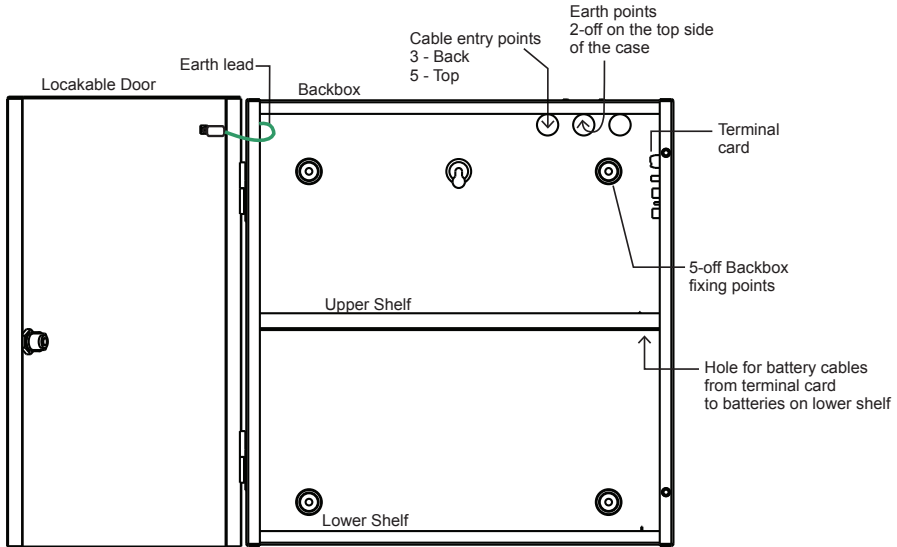

## 19 inch Rack mounting frames

The diagrams below show the rack mounting frames for the control panel and battery box that can be mounted onto a 19inch Rack.

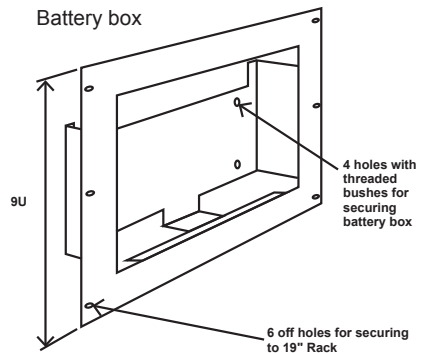
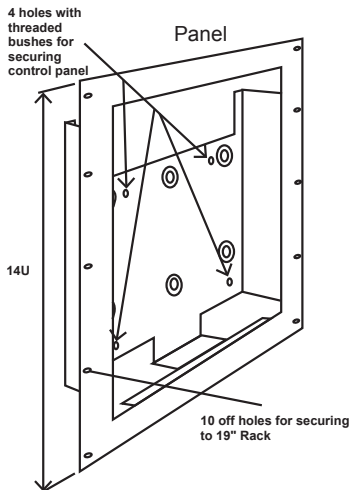

## Wiring the battery box

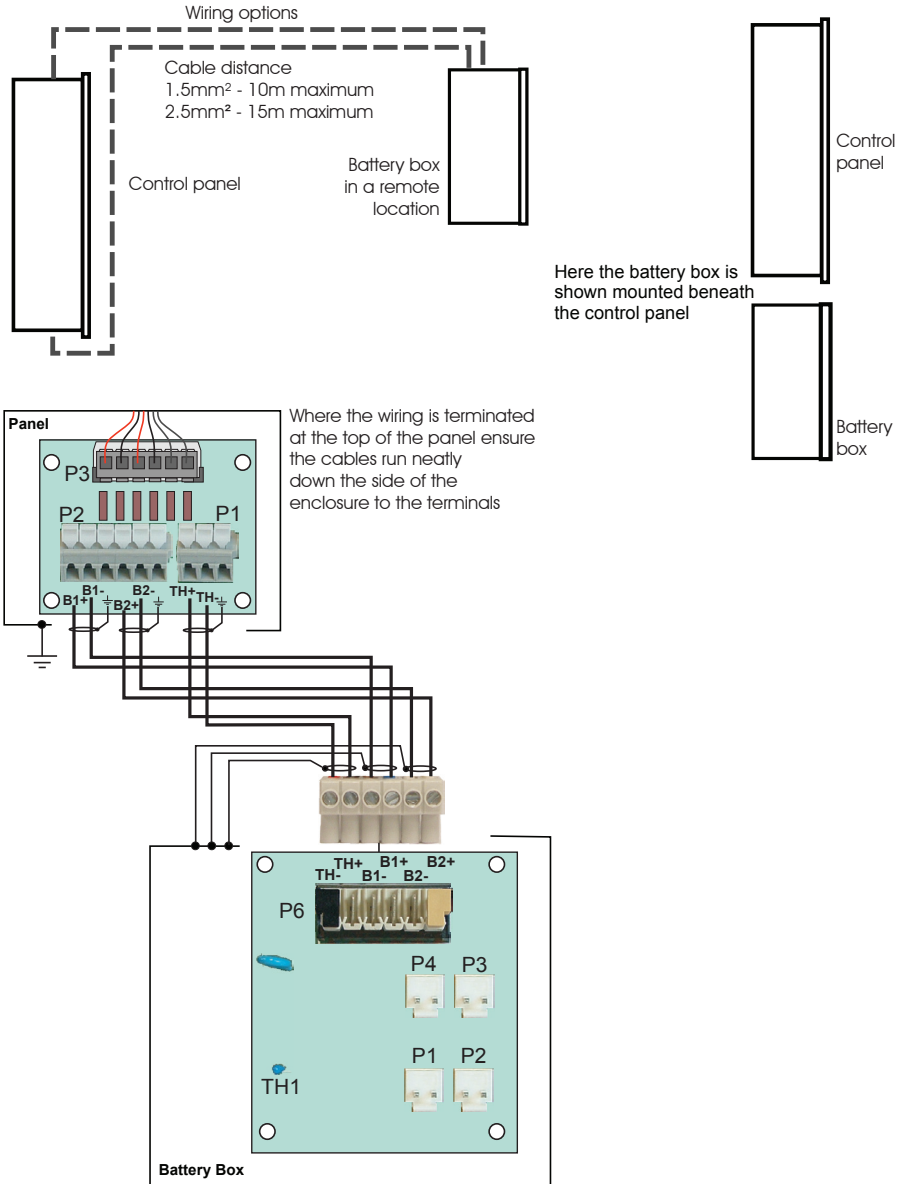

To maintain earth continuity, an earth lead (not supplied), is required to be fitted to an earth point in the control panel with the other end to an earth point in the battery box.

## Cable termination on enclosure

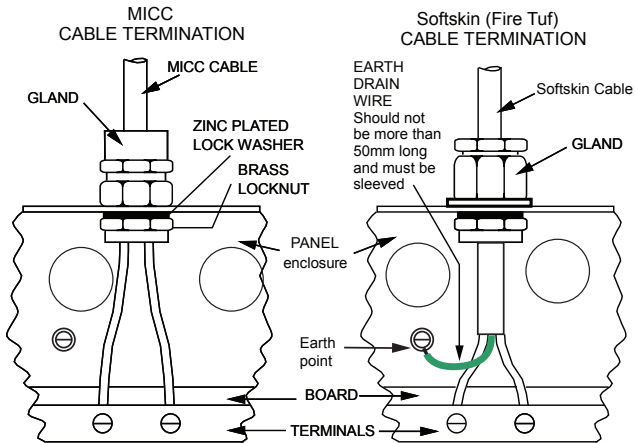

The wire length between the cable termination and point of connection must be as short as possible. Cable earth drain wire, where applicable, must be connected to the nearest earth point.

Terminate each cable at the dedicated entry point on the enclosure, using the cable manufacturers recommended techniques.

Where cables are not required to be connected to terminals then leave **400mm** tail wire length (unless otherwise specified) and mark each **core** identifying its final point of connection. Where the cable is required to be connected, ensure it is secured to the respective terminal.

## Wiring tests



**Don't undertake high voltage insulation tests WITH THE CABLES CONNECTED to the panel and system device terminals. Such a test may damage the electronics circuitry in loop devices and at the panel.**

## Mains & battery supply cables

The mains and battery supply cables must be installed to the stage to facilitate the power up for commissioning, which is carried out by the Servicing organisation.



**Where mains cable is to remain disconnected, its tail ends must be insulated to prevent dangerous conditions arising in the event of accidental switching On of the mains supply.**

## Mains supply



Ensure that the mains supply cable enters the panel through a dedicated cable entry point.



These fire alarm system products are **NOT** designed to be powered from IT Power systems.

All mains powered equipment must be earthed. The mains supply to the control panel must be via an unswitched 5A fused spur unit. A **disconnect device** must be provided to disconnect both poles and must have a minimum gap of 3mm. The disconnect device should be available as part of the building installation and must be easily accessible after the installation is complete.

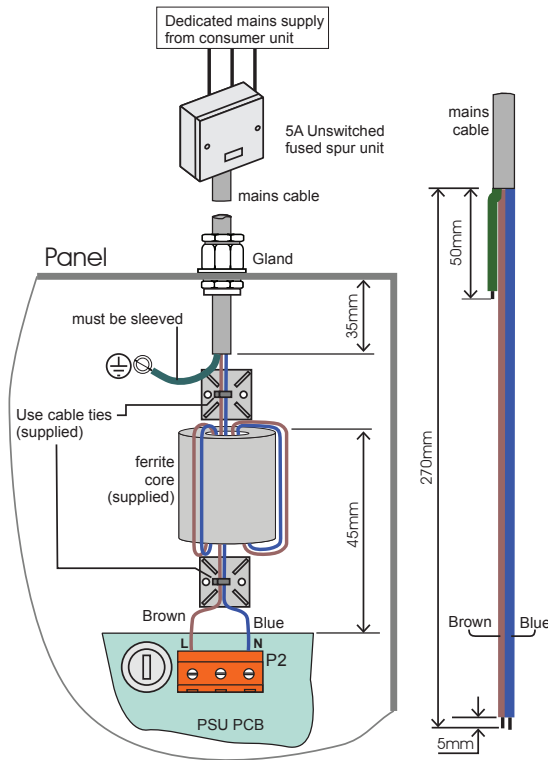

The mains cable must be stripped back to the length shown to allow live and neutral wires to be wound twice through the ferrite core.

The fused spur isolator cover should be marked:

**FIRE ALARM - DO NOT SWITCH OFF**

The fire alarm equipment's fused spur unit must be fed from a dedicated switch or protective device at the local mains supply distribution board.

## Terminals for external circuits

The Terminal card holds all the terminals for the connection of external circuits. The exceptions are:

- terminals for CARDS in slots P7 and P8, these are located on the Backplane
- terminals for mains supply, these are located on PSU
- terminals for batteries, these are also optionally located on the PSU.

### Backplane

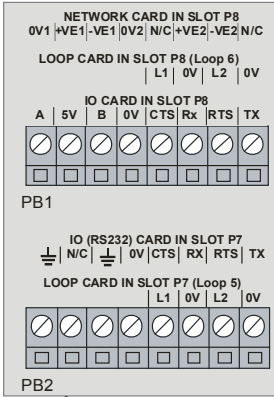

### Terminal card

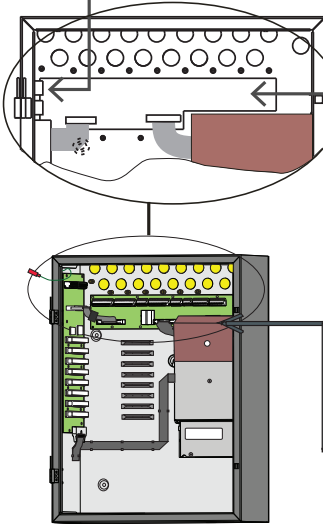
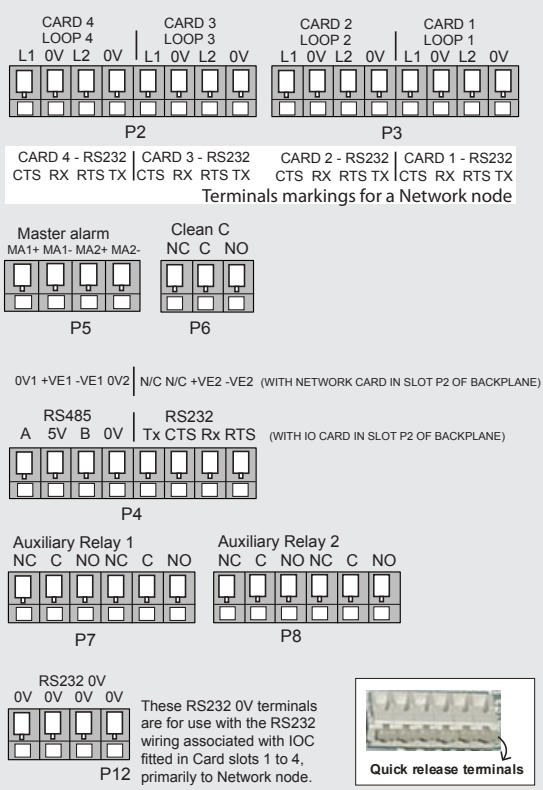

### PSU board (located behind the cardboard cover)



## Device loop circuits

Upto 4 device loop circuits can each accept the connection of compatible addressable devices / outstations communicating on Vigilon 3217 protocol. Where a maximum of up to 200 devices / outstations are allowed per device loop circuit. To maintain earth continuity on a loop, the loop cable screen must be continued through each system device, whether the earth is connected to a device or not.



**A loop circuit must not cover more than 10,000m<sup>2</sup> of floor area of a protected site.**

**A spur circuit must always be taken from the “line common” terminals of a 3 ways device.**

**A spur must not cover more than the equivalent of one zone as defined in BS 5839 Part 1.**

**As every loop device has an isolator fitted, it is not necessary to apply special attention where there are more than 32 devices. However no more than a maximum of 512 fire detectors and/or manual call points shall be installed on one control panel.**

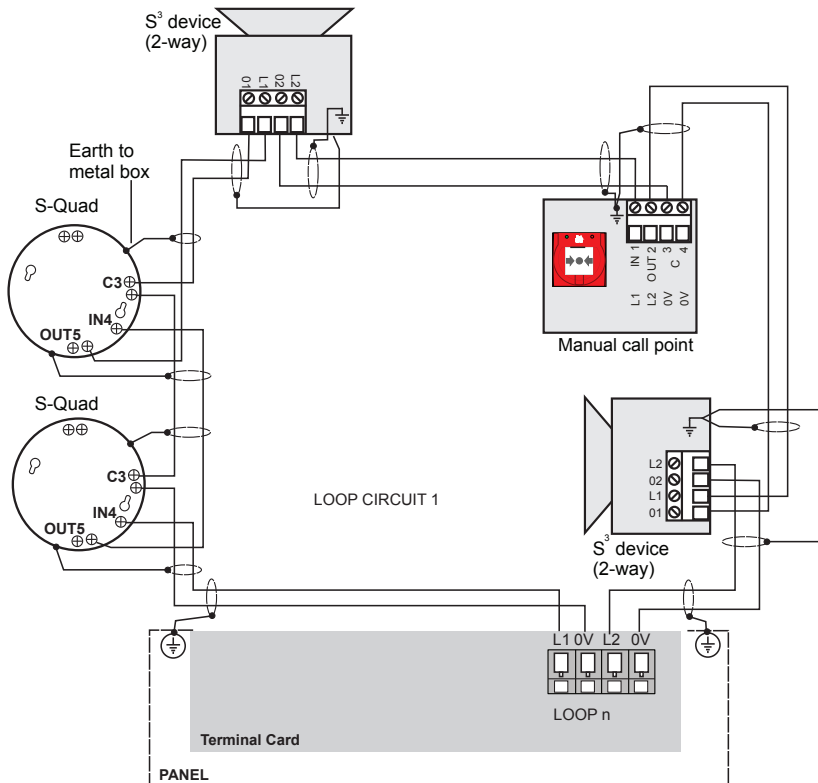

## Master alarm circuits

The two master alarm circuits accept the connection of conventional alarm sounders, such as the conventional audio and visual alarm products.

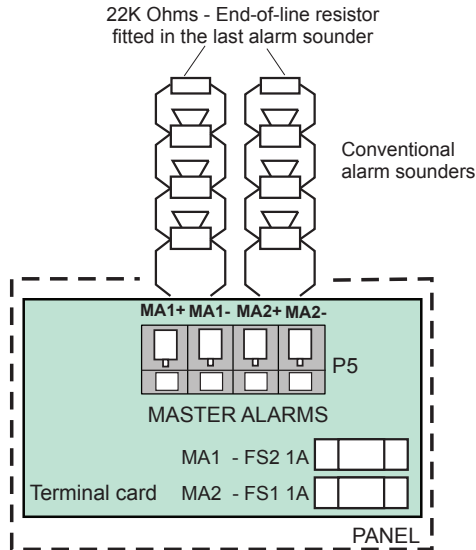

## Clean contacts

The control panel operates the clean contacts relay when a fire event is received from the system. The clean contacts can be used to switch plant equipment, such as lift control system. If required, the contacts should be powered from an independent power supply.

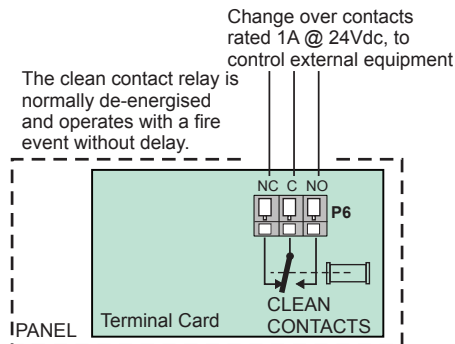

## Auxiliary relay circuits

The control panel operates the auxiliary contacts when the configured event is received from the system.

The auxiliary relays 1 and 2 contacts can be used to control external equipment, such as an automatic dialer that makes the call for fire fighting action. The relays can be individually re-configured to operate with either fire, fault or disablement event in the system.

The relay operation can also be delayed by up to 10 minutes and can be set up to operate in a normally energised or de-energised state. The contacts should be powered from an independent power supply, where required.

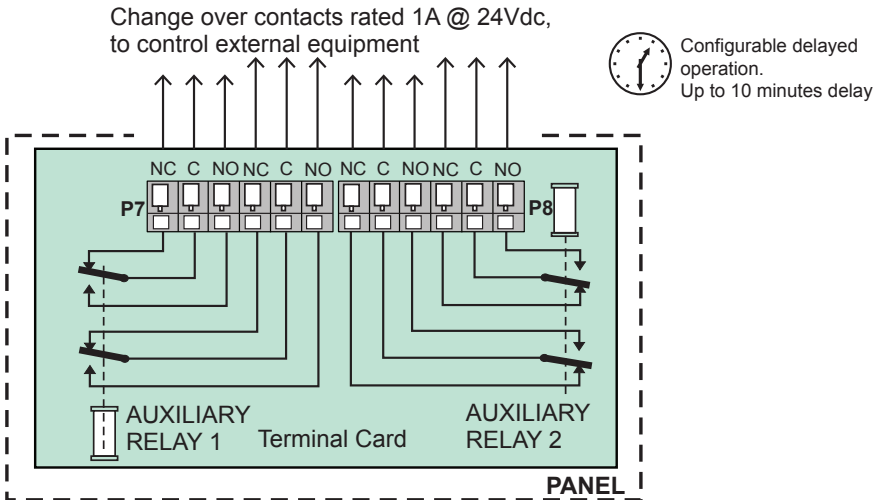

Factory default:

Aux relay 1 is normally de-energised and operates with a fire event without delay.

Aux relay 2 is normally energised and de-energises with a fault event without delay.

Note: Aux relay 2 has been shown in the above diagram in its de-energised state, which is the state when there is no power to the panel.

## RS232 / RS485 Communication

The control panel offers RS232 and RS485 communication via the IO card.

A standard IO card (not supplied) must be inserted in slot P2 of the backplane of the panel, which facilitate RS232 and RS485 communication via terminal block P4 on Terminal card. Note RS232 is PORT 0 and RS485 is PORT 1 when an IO card is fitted in slot P2. The domain address and communication baud rate are configured by setting the DIL switch located on the left edge of the Display Keyboard card.

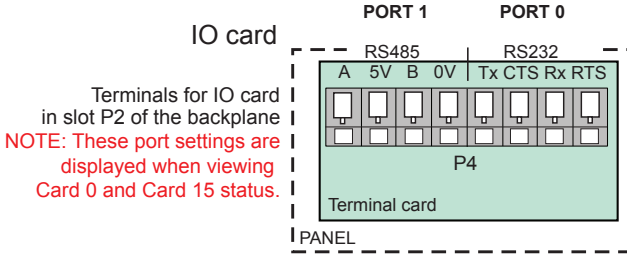

### IO, Network or Loop card option

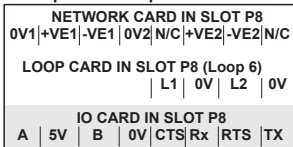

### IO or Loop card option

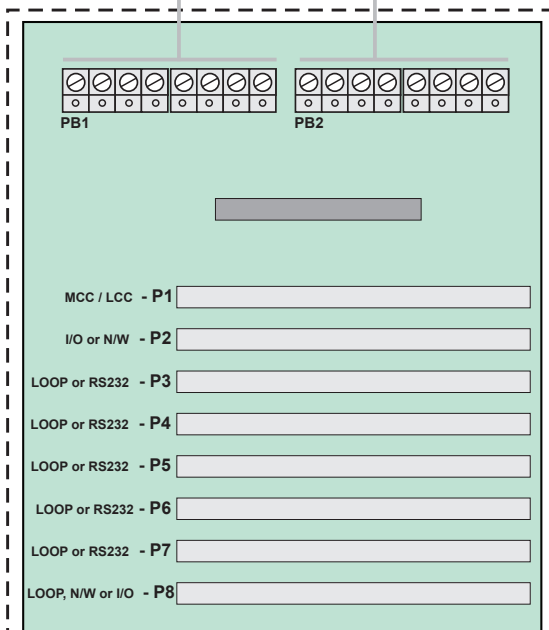
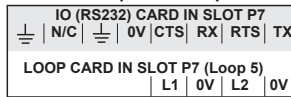

## Connecting a Remote printer

An IO card (not supplied) must be inserted in slot P2 of the backplane of the panel, which will facilitate remote printer functionality. When a remote printer is connected to a standalone Vigilon Plus control panel, it will print local system events.

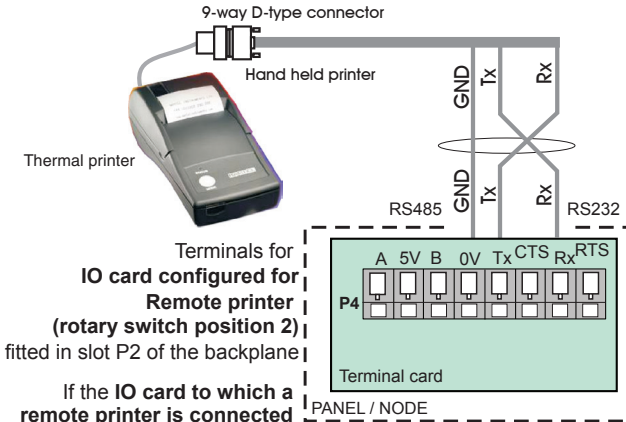

## Network systems

It is possible to network together up to 31 Vigilon Plus Control panels and Vigilon Plus Network Nodes, each fitted with a network card for network connections. The Network card permits communication between other control panels and network nodes. The cable distance between panels and nodes can be up to 1.2Km maximum when copper network card is fitted panels. Up to 2km maximum is possible when a fibre network card is fitted. A network node is a central point for information about the networked system.

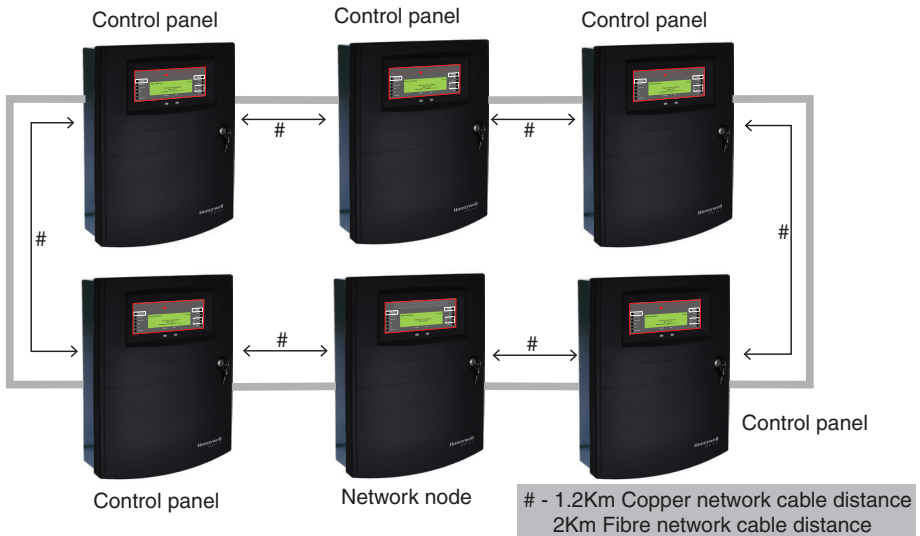

## Network connections

A secure network can consist of up to 31 control panels and network nodes connected in a loop, communicating on Vigilon 3217 protocol.

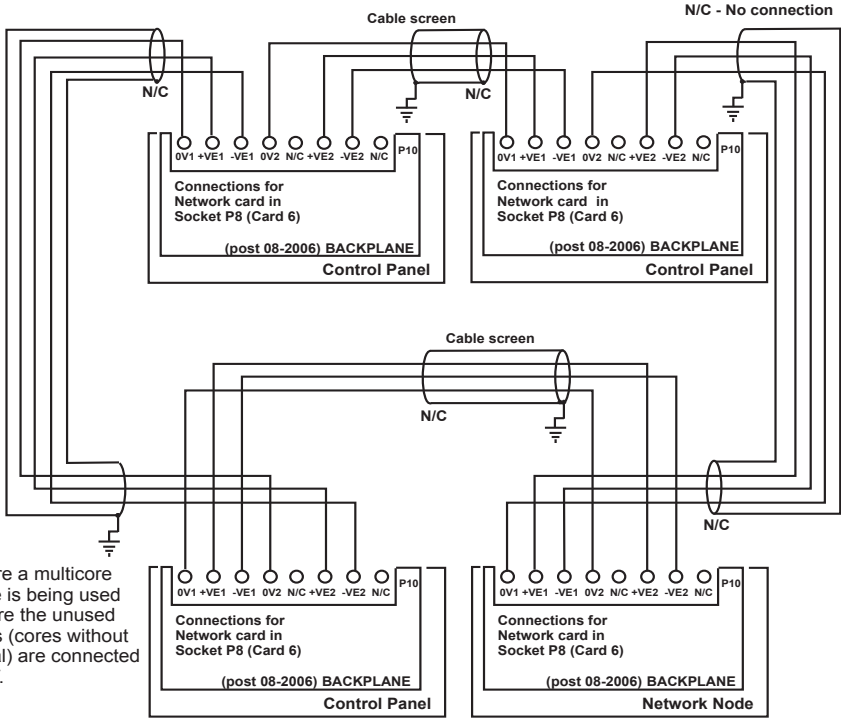

## Copper network connections

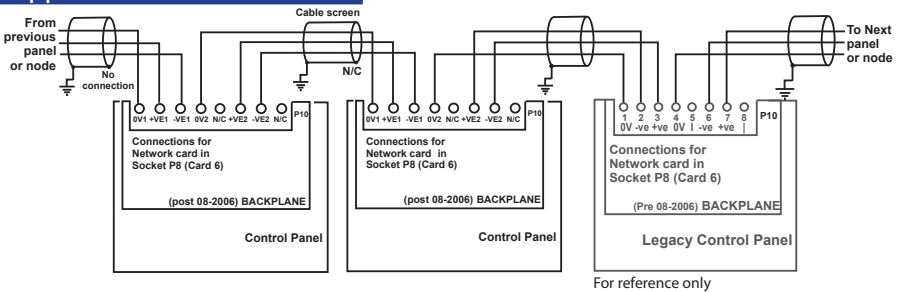

## Network wiring

In countries where the European EMC directive is in force use only those cables that are EMC Compliant, see list under the heading Network cables.

The recommended cables listed in this manual should be used to interconnect control panels and network nodes.

## Fibre network connections

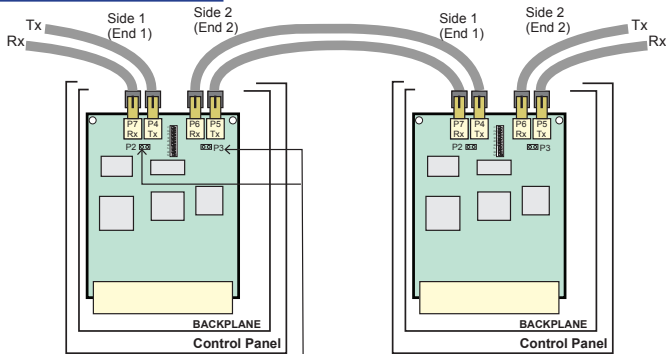

Links P2 and P3 are booster links. Normally the links are not fitted, however for distance exceeding 750m the links must be fitted.

## Network cable screen continuity

**NOTE:** The cable screens are not connected to earth at the joint or at Panel 2.

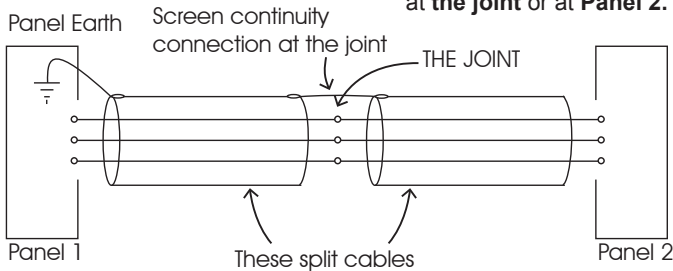

Ensure a good screen continuity joint exists where there is a split cable.



**DO NOT mix cables of different types on the same leg of a network, as this will create impedance imbalance and disruption to data communication.**

## How to minimise cross talk



**When using standard MICC cable in a network the different legs of the cable must not be closely placed together, as this will cause signal crosstalk which results in communication failure.**

There are three practical ways of overcoming the crosstalk problem:

- ▣ use a twisted-core MICC cable
- ▣ put a ferrous screen between the cables (ie in the two runs of steel conduit)
- ▣ maintain a distance between the network cables of at least 50mm

## Domain Bridge across Networks

It is possible to connect two or more Vigilon networks together by means of domain bridge. To domain bridge two or more networks a Domain bridge IO card must be installed in the bridging node / panel.

There are various methods of domain bridging depending on the distances between node / panel. Domain bridge can be made directly using RS232 ports of the IO card, via modem, Fibre optics or via dedicated network using NPORT units.

### Methods of domain bridging

A domain bridge IO card is required to be installed in the bridging panel/node.

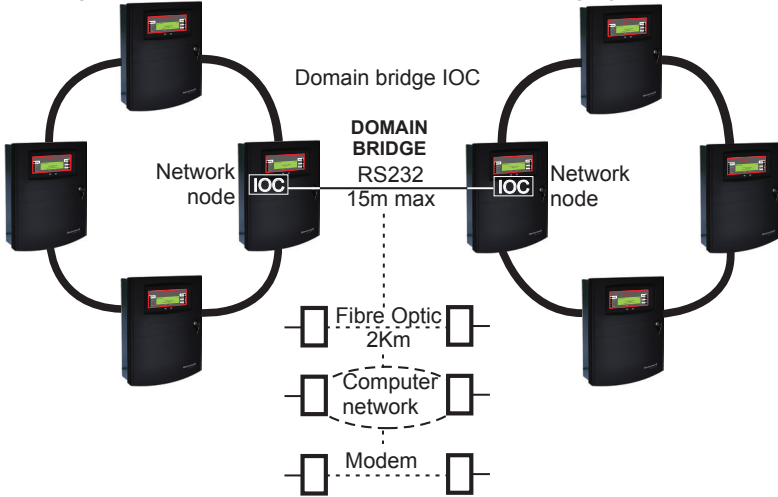

### Star connection

**i** If remote sites are residential then it is not permissible to rely on domain bridge link to call the fire brigade.

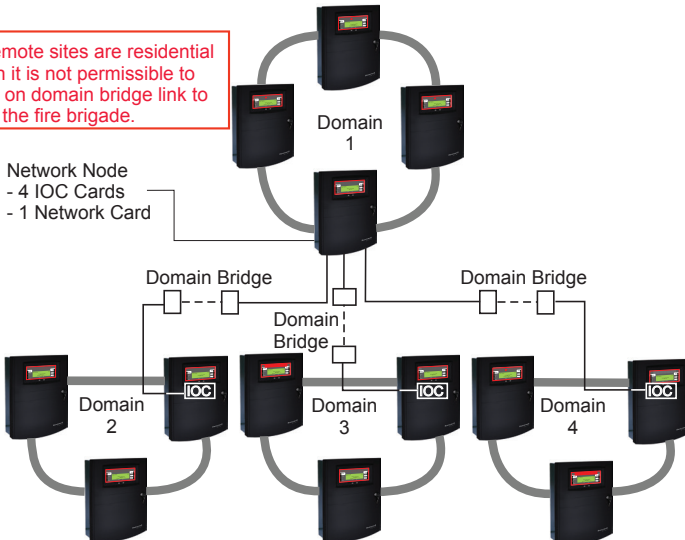

## Fibre Optic Domain bridge using FO Network DOM card

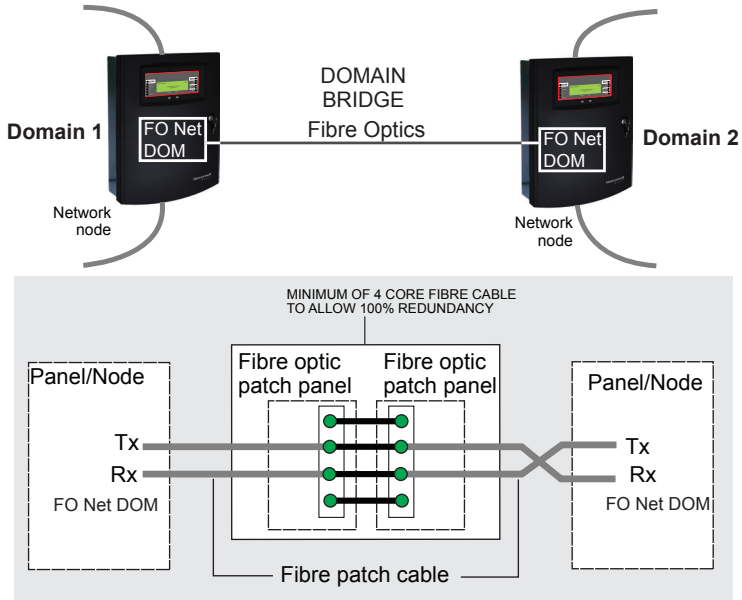

## RS232 Domain bridge using Domain IO card

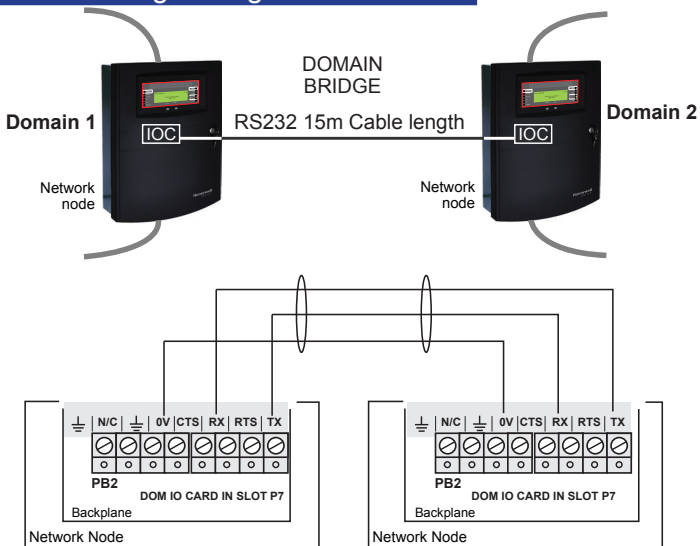

## Domain bridge using NPORT module

The customer is to supply the IP addresses.

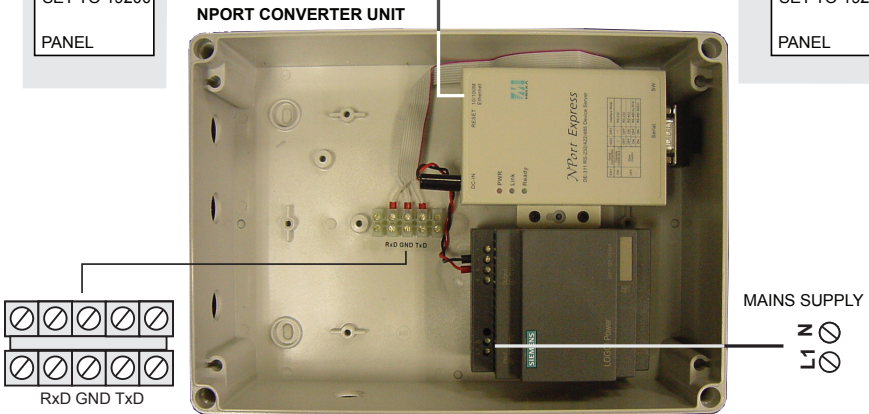
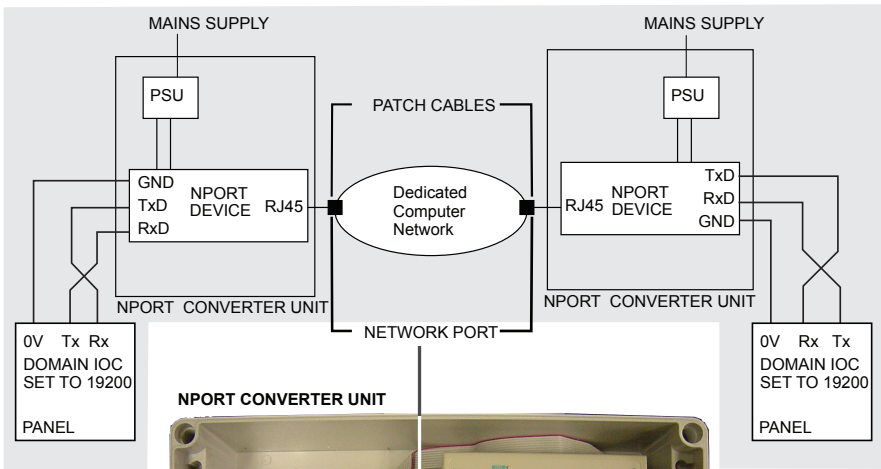
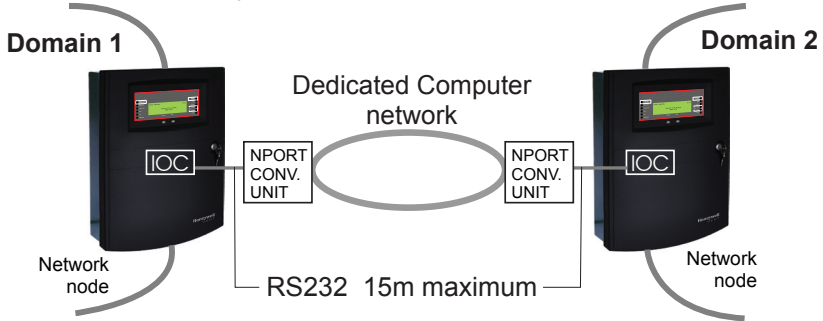

**PARTS REQUIRED FOR EN54 SETUP**  
 2 x VIG-IO-DOM  
 2 x VIG-NPORT-100

**REQUIRED:**  
 2 X IP NETWORK INFORMATION  
 2 X NETWORK PORTS  
 2 X PATCH CABLE

## Modem Domain bridge

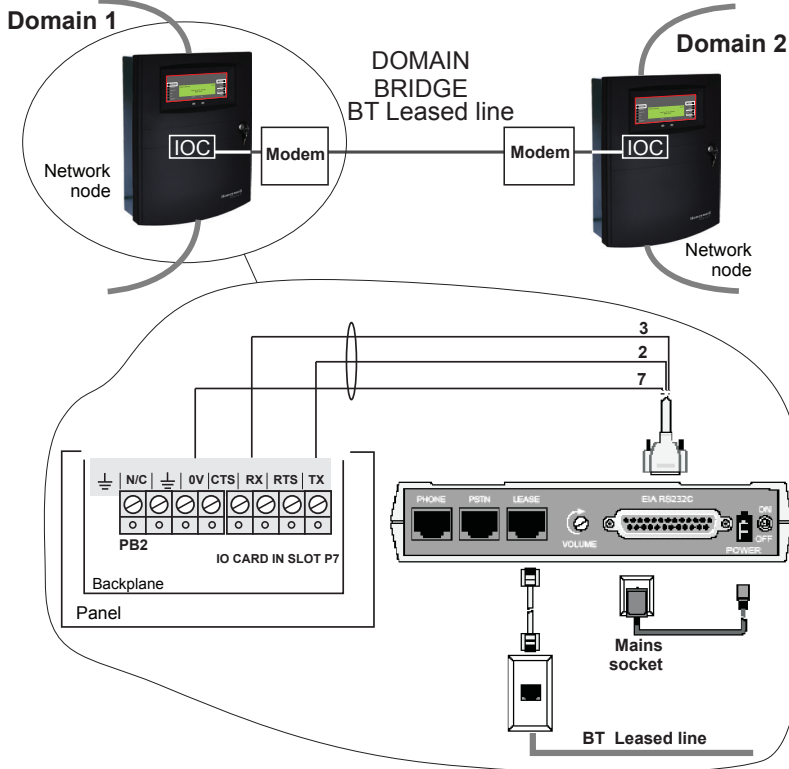

## On completion of wiring installation

On completion of all wiring refit the temporary cover onto the back box. All outstanding work is done by the servicing organisation during commissioning.

## S-Quad Sensors



This following is shortened version of the information on the S-Quad product range, for full information see the S-Quad data sheet (4188-1073 or 4188-779 for legacy S-Quads).

The S-Quad product integrates dual angle smoke, heat and carbon monoxide gas detection with electronic sounder, speech and LED flasher in one assembly.

Information on S-Quad Devices can be downloaded from [www.gentexpert.co.uk](http://www.gentexpert.co.uk) by registered users.

### Base

The base has terminals for external cables, for the wiring of loop circuit and monitored input or output circuit. Any S-Quad device can be plugged into an S-Quad base.

### IP21 Base

An IP21 Base Gasket prevents water damage from dripping water from the ceiling.

An optional label (Part No: 805576) can be fitted to the base.

Where a label is used it can be marked up with device location information before it is fitted to the Base.

### Indicators

The S-Quad has a red LED that gives an indication in the event of a fire. The LED can be configured to flash periodically, as an 'in operation' confirmation, this indication is given system-wide at all S-Quads. The S-Quad with a CO sensor also has a blue LED to indicate when a fire signal senses the presence of CO.

### Dust Cover

A dust cover is supplied with the S-Quad, to prevent dust from building work contaminating the sensor. The cover is removed prior to the commissioning of the fire alarm system.

## Siting

A S-Quad device plugs into a dedicated Base that is installed in the protected premises. The Bases should be sited in locations as defined by the project plans and by BS 5839 : Part 1 : 2013.

### Do's and Don't



**Follow recommendations detailed in section 22 that relate to automatic fire detectors and section 16 that relate to alarm sounders in BS5839 : Part 1 : 2013.**

**DO Locate Visual Alarm Devices in accordance with Loss Prevention Council Code of Practice CoP 0001.**

**<http://www.redbooklive.com/lps.jsp>**

**DO NOT locate smoke detectors where products of combustion may be present such as in kitchens, garages, furnace rooms, welding shops etc.**

**DO NOT locate heat detectors above boilers or heaters or where the temperature is normally very high or liable to sudden fluctuations.**

**DO NOT locate smoke or heat detectors: -**

- In dusty or dirty environment.
- Near heating or air-conditioning grilles.
- Outdoors in stables, sheds etc.
- In excessively damp areas.
- In dead air spaces at the junctions of ceilings and walls.
- At ceiling locations where a 'thermal barrier' may exist.

**DO NOT locate a CO detector: -**

- In buildings where farm animals are kept.
- In excessive damp areas.
- In battery room where non sealed battery are kept.
- In a Car park where exhaust fumes will be present.

### Metal back box

A metal back box must be used for surface or semi-flush mounting. The earth continuity must be maintained throughout the whole loop. **The earth must be securely connected to the back box.**

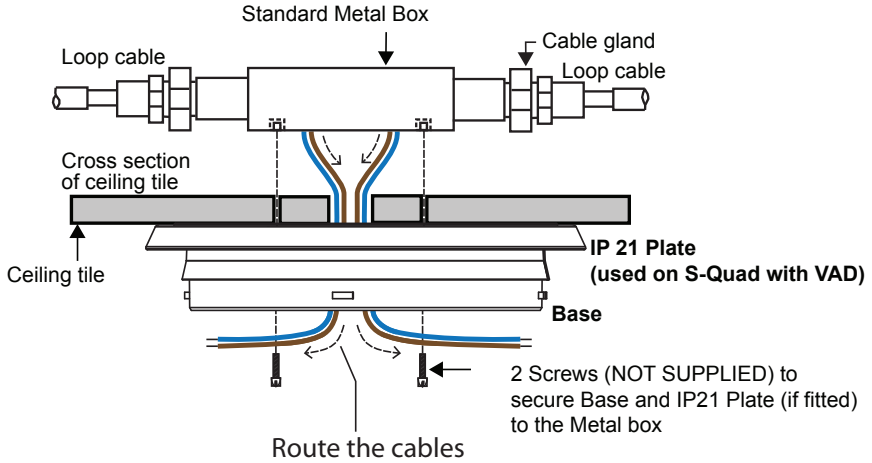

### In - Out wiring to S-Quad bases

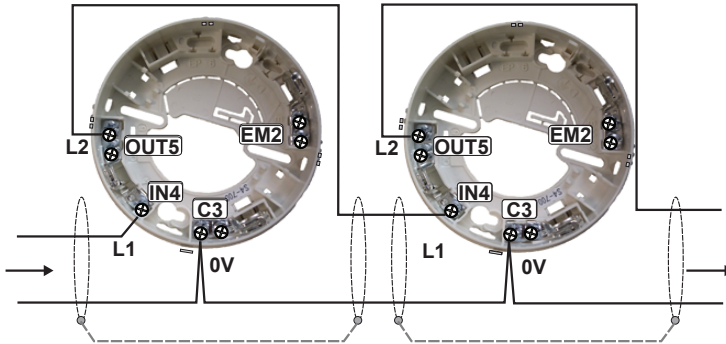

## Programmable input/output

All S-Quad devices can be configured as either monitored input or unmonitored output. The factory setting of the programmable input / output is unmonitored output, to drive an external repeat LED without a series resistor. There is a maximum cable length limit of 15 metres from the S-Quad base to the external I/O Unit.

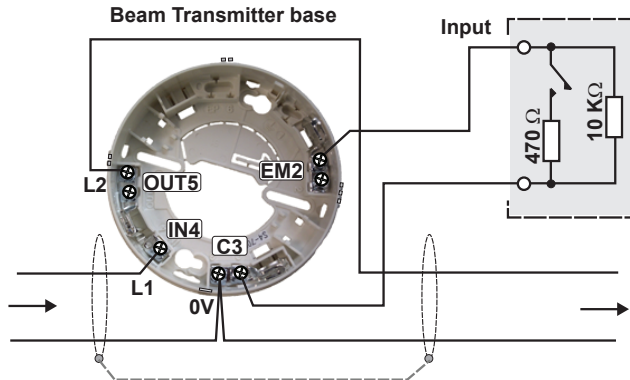
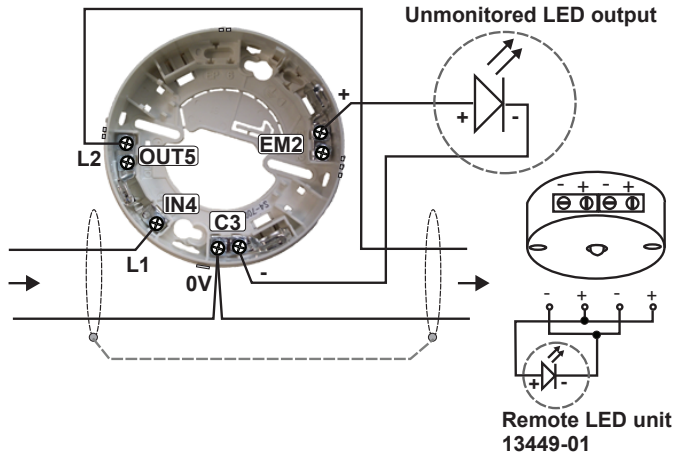

The input can accept signals such as fire, non fire or fault, these are configured during commissioning. As a fire input it is possible to connect a conventional Manual Call Point (non UK application only) with a series resistor of value 470 Ohms coupled with an end-of-line 10Kohms resistor. In this case the fire input is fully monitored for open or short circuit faults.

The input can be setup as a non-fire or fault input using a similar arrangement with series and parallel resistors as shown. It is possible for such an input to trigger a command that is configured to action an output elsewhere in the system to control plant equipment such as ventilation system in a building.

### Tools for S-Quad

An extractor tool allows removal and fitting of the S-Quad device head into the base. By fitting a screw-on adaptor, the tool can also be used to remove the sensor dust cover.

#### To remove an S-Quad

Fit the tool onto the S-Quad. Turn S-Quad anticlockwise until it stops and remove the S-Quad from the base.



#### To fit an S-Quad

Fit the S-Quad on to the tool. Offer S-Quad to base and rotate clockwise until it moves upwards in to the base and rotate it again until it clicks and goes no further, the lines on the base and S-Quad will align.



#### To fit a dust cover

Place the dust cover onto the tool inside the cradle. Offer the cover to the S-Quad, locate and push to fit it onto the assembly. Withdraw the tool when the dust cover is in place.



#### To remove a dust cover

A dust cover remover tool must be fitted to the main tool to extract the dust cover. Press the pad of the dust cover remover tool onto the dust cover, this creates an air tight grip, to allow the cover to be pulled off from the S-Quad.



## Vigilon plus panel parts

This section lists parts associated with the Vigilon panel based system. For further information on the availability of the parts contact your supplier.

### Control Panel

VIGPLUS-24	Vigilon Plus Control panel <b>with printer</b> (24 hour standby) c/w 1 loop card and 2 x 12V 21Ah batteries
VIGPLUS-24-NP	Vigilon Plus Control panel <b>without printer</b> (24 hour standby) c/w 1 loop card and 2 x 12V 21Ah batteries
VIGPLUS-72	Vigilon Plus Control panel (72hour standby) c/w 1-loop card, battery box and 4 x 12V 21Ah batteries

### Spares

4015-602-Y	12V 21Ahr Battery
VS-PROLL	Spare thermal paper for the integral printer
VS-KEY	Outer door key

### Cards

VIG-LPC-EN	Loop Card (EN54) up to 2Km
VIGPLUS-MCC	Main Controller Card (EN54) spare for VIGPLUS-24 & VIGPLUS-72
VIG-NC	Copper Network Card
VIG-NC-FO	Fibre Optic Network Card for VIGPLUS-24, VIGPLUS-72 & Node
VIG-IOC-DOM	Domain Bridge Input/Output Card (EN54)
VIG-NC-DOM-FO	Secure Domain Bridge Card Fibre Optics Network Card for VIGPLUS-24, VIGPLUS-72 and Network node

### Accessories

VIG-24-FLUSH	Flush mounting kit for VIGPLUS-24 and Network node
VIG-FLUSH-SS	Stainless steel flush surround for VIGPLUS-24 and Network node
VIG-DOOR-SS	Stainless steel door
VIG-19-RACK	19" Rack mounting frames for panel and battery box
VIG72-UPGR	Upgrade Kit to convert VIGPLUS-24 to VIGPLUS-72 (includes power supply and 2 x 21 Ah Batteries and Battery box)

**Network Node**

VIGPLUS-NODE                      Network node

**Domain Bridge products**

VIG-NPORT-100                      NPORT IP Domain module 100m (single unit)

VIG-DOM-MODEM                      Modem pair

**Printer**

PRINTER-HAND                      Handheld serial thermal printer

PRINTER-H-PAPER                      Thermal paper for handheld printer

**Manuals**

4188-1025                              Vigilon Plus 4/6 loop panel & Plus Network Node based system - Operating instructions

4188-749                                Log book

**S-Quad - Sensors**

The latest S-Quad publications lists the product range. These publications can be downloaded from [www.gentexpert.co.uk](http://www.gentexpert.co.uk) by registered users.





0832

Honeywell Gent  
Manufactured by: Honeywell Gent (Novar Systems Limited),  
140 Waterside Road, Hamilton Industrial Park,  
Leicester, LE5 1TN, United Kingdom

16

DoP	Product No.
129-CPR-2016	VIGPLUS-24
129-CPR-2016	VIGPLUS-24-NP
129-CPR-2016	VIGPLUS-24-PO
129-CPR-2016	VIGPLUS-24-SP
130-CPR-2016	VIGPLUS-72
130-CPR-2016	VIGPLUS-72-PO
130-CPR-2016	VIGPLUS-72-SP

EN54-2: 1997 + A1:2006, EN54-4: 1997 + A1: 2002 + A2: 2006

VIGPLUS-24	(EN54-2 & 4)
VIGPLUS-24-NP	(EN54-2 & 4)
VIGPLUS-24-PO	(EN54-2 & 4)
VIGPLUS-24-SP	(EN54-2 & 4)

VIGPLUS-72	(EN54-2 & 4)
VIGPLUS-72-PO	(EN54-2 & 4)
VIGPLUS-72-SP	(EN54-2 & 4)

Intended for use in fire detection and fire alarm systems  
in and around buildings

Refer to DOP 129-CPR-2016 & 130-CPR-2016 for level or class of  
performance declared, for details see website [www.gent.co.uk](http://www.gent.co.uk)



**WEEE Directive:**

At the end of their useful life, the packaging, product  
and batteries should be disposed of via a suitable  
recycling centre.

Do not dispose of with your normal household waste.  
Do not burn.



**At the end of their useful life, the packaging,  
product and batteries should be disposed of  
via a suitable recycling centre and in  
accordance with national or local legislation.**

Honeywell Gent reserves the right to revise this publication from time to time and make changes to the content hereof without obligation to notify any person of such revisions of changes.

**Honeywell**  
GENT

Hamilton Industrial Park, Waterside Road, Leicester LE5 1TN

Website: [www.gent.co.uk](http://www.gent.co.uk)

Telephone:  
+44 (0) 116 246 2000

Technical support:  
[www.gentexpert.co.uk](http://www.gentexpert.co.uk)

Fax (UK):  
+44 (0) 116 246 2300