

# Hybrid Network Card (VIG-NC-HYBRID)

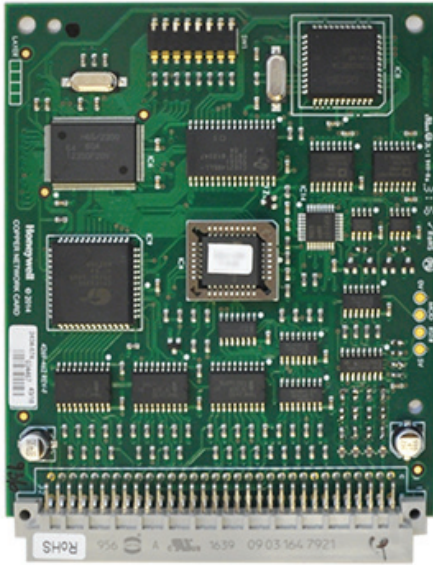

V4-xx chip

The Hybrid Network Card (VIG-NC-HYBRID) is used in the process of converting a BS Vigilon Network to an EN Vigilon Network.

### Compatibility

An EN compliant Vigilon panel communicate with a different protocol from the legacy non-compliant BS Vigilon and 3400 panels in the UK. The Hybrid Network card allows coexistence of legacy BS fire panels/nodes and EN fire panels/nodes on the same network. This allows phased planned upgrade of the network from BS to EN over a period of time.

The Part 1 of this leaflet provides general information on the Hybrid Network Card to include technical data, external wiring and DIL switch settings.

### Wiring

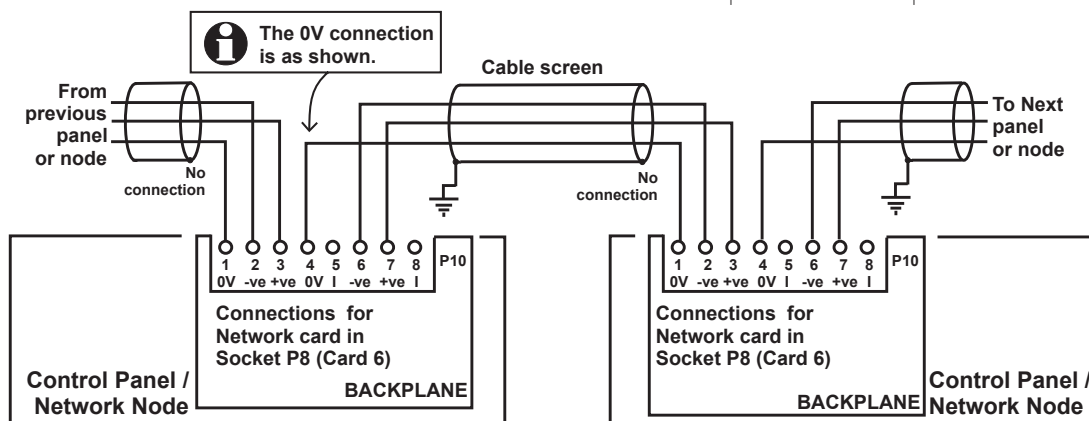

### Upgrade process to convert a BS to an EN Network

The upgrade work to convert a BS Vigilon network to an EN Vigilon network is carried out by engineer who has received training.

- The first phase in the process involves the installation of Hybrid Network card in each BS panel/node to allow communication on EN network protocol.
- The second phase is the conversion of BS panels/nodes to EN, which involves complete replacement of panel/node and cards, plus using the Hybrid Network Card with V4.xx chip. Also the system configuration files for each panel/node will need their cause and effect converted from BS to EN using a Configuration Converter tool.

Any BS Repeat panels and A4/A3Mimic Repeat panels on the loops will need to be replaced or upgraded.

*Any Repeat panels manufactured after 2007 are compatible with both BS and EN loop protocol.*

Detailed procedures on how to convert a BS network to an EN Network is covered in Part 2 of this leaflet, which can be downloaded by registered users of GentExpert website.

### Technical data

Overall size in mm	128height x 100 width x 10 depth
Weight	72g (approximate)
Operating temperature	0°C to +45°C
Storage temperature	-10°C to +55°C
Relative humidity	up to 90% (non condensing)
Node address range	1 to 31
Baud rates	2400, 9600, 19.2K and 38.4K
Operating voltage	±5V (RS485)
Cable for wiring	Belden 9729, see panel installation manual for full list of approved cables

A maximum of up to 31 Vigilon Control panels and Network nodes can be connected in a secure network loop, with up to 1.2Km cable distance between panels/nodes dependent on cable type.

# Data and Installation

## Dual In Line (DIL) switch settings

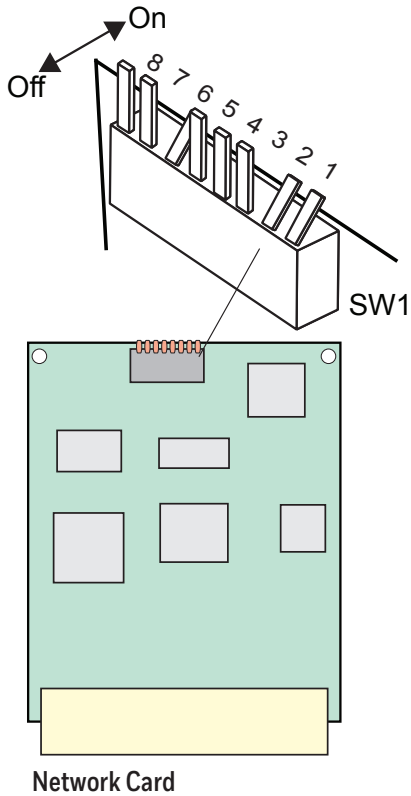

Card label	Backplane socket	Card
MCC / LCC	P1	CARD 0
IOC / NC	P2	CARD 15
LOOP 1	P3	CARD 1
LOOP 2	P4	CARD 2
LOOP 3	P5	CARD 3
LOOP 4	P6	CARD 4
IOC / NC	P7	CARD 5
NC	P8	CARD 6

MCC - Main Control Card  
 LCC - Local Controller Card  
 IOC - Input Output Card  
 NC - Network Card  
 LOOP n - Loop Processor Card

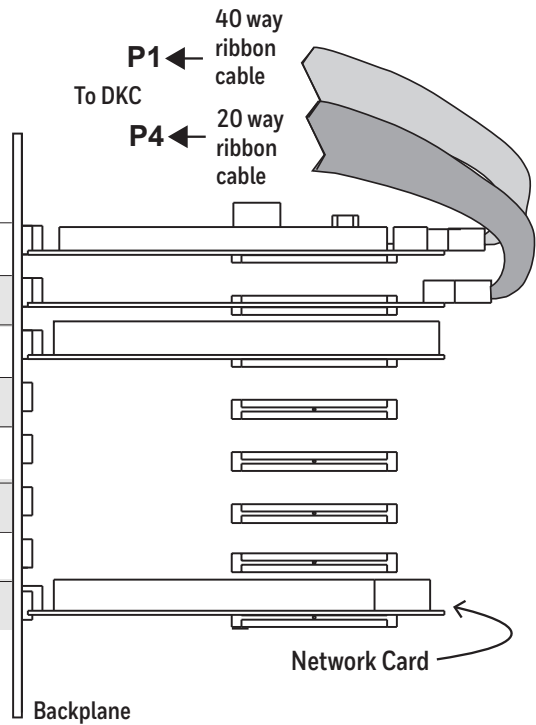

Node address switch numbers and settings							Baud rate switch numbers and settings		
	8	7	6	5	4	3	2	1	
64	Off	Off	Off	Off	Off	Off	Off	Off	2400
1	On	Off	Off	Off	Off	Off	On	Off	9600
2	Off	On	Off	Off	Off	Off	Off	On	19.2K
3	On	On	Off	Off	Off	Off	On	On	38.4K
4	Off	Off	On	Off	Off	Off			
63	On	On	On	On	On	On			
	Address						Baud		
	- Factory settings								

At the end of their useful life, the packaging, product and batteries should be disposed of via a suitable recycling centre and in accordance with national or local legislation.

**WEEE Directive:**  
 At the end of their useful life, the packaging, product and batteries should be disposed of via a suitable recycling centre.  
 Do not dispose of with your normal household waste. Do not burn.

Honeywell Gent reserves the right to revise this publication from time to time and make changes to the content hereof without obligation to notify any person of such revisions of changes.

	Hamilton Industrial Park, Waterside Road, Leicester LE5 1TN, UK.	Website: <a href="http://www.gent.co.uk">www.gent.co.uk</a>
	Telephone: +44 (0) 116 246 2000      Tech. Support <a href="http://www.gentexpert.co.uk">www.gentexpert.co.uk</a>	Fax (UK) +44 (0) 116 246 2300

The following procedures describe what is needed and how to convert and upgrade a secure non-complaint BS Vigilon Network to a secure compliant EN Vigilon Network.

The upgrade process involves the installation of temporary Hybrid Network Card in each BS panel/node, for the network to communicate on EN protocol with minimal loss of network coverage. The temporary network is then gradually upgraded with phased work to convert each panel/node of a standalone system from BS to EN.

## What will I need?

You will need a quantity EN Vigilon panels/nodes plus cards and Commissioning and Configuration Converter tools.

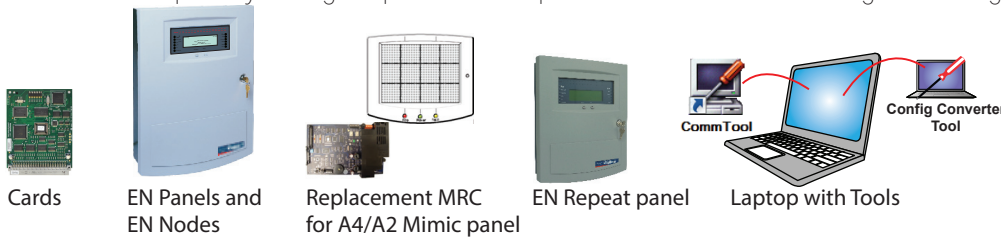

- Hybrid Network Cards (VIG-NC-HYBRID) for temporary installation in BS panels/nodes to allow network upgrade
- EN Vigilon panels to replace existing BS panels in the network
- EN Network Nodes to replace existing BS Nodes in the network
- EN Cards for panel/node as required, determined during the Site Survey
- EN Repeat panels to replace BS Repeat panel installed on loop circuits
- Replacement MRC Cards for A4/A2 Mimic panels on loop circuits
- Commissioning tool (V1.33)
- Configuration Conversion Tool (V1.0)

## Assumption

It is assumed that any sub loops on a main loop circuit are rewired and configured as spur circuits before commencing work to convert and upgrade a BS network to an EN network.

## Site Survey

The first thing to do is survey the BS network of panels/nodes and Repeats/Mimics on loops, to determine what needs upgrading.



As a general recommendation:

- Replace BS panels/nodes with EN panels/nodes. *(If a BS panel was manufactured after 2007 it will have been converted from EN to BS with a BSKIT and so the conversion to EN may involve installing compatible EN cards and relabelling of membrane LEDs.)*
- For any A4/A2 Mimic panels wired on loops or those manufactured before **August (Week 35) 2008**, these will require installation of Replacement MRCs.
- Replace all BS Repeat panels on loops with EN Repeat panels. Except for EN/BS Repeat panels manufactured in **2007**, these are compatible with both BS and EN loop protocol.

### How to find the date of manufacture of a Card.

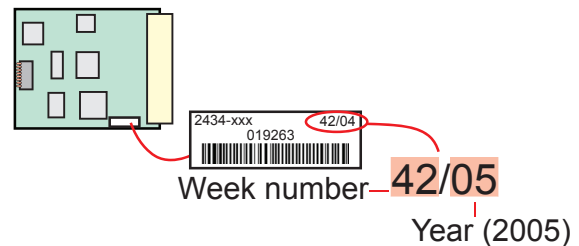

### How to find the date of manufacture of Panel/Node.

The date of manufacture can be found on a label fitted to the side of the inner box of a panel/node.

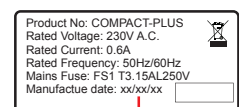

xx/xx/xx  
Day Month Year

## Upgrade of Panels / nodes to EN and time frame

The upgrade of panels/nodes from BS to EN is to be completed within a time frame not exceeding 3 years. A Hybrid network is intended to help achieve a smoother upgrade of older non-compliant networks. It will provide a secure network system where all fire detection and cause and effect will operate as required.

Due to the differences between the older BS and the current EN54 protocols there are some events that are passed by the new panels that are not recognised by the legacy BS panel. This will result in potential differences in the number of faults or warnings from panel to panel and some events will not be recognised and therefore will not be displayed correctly. For this reason the Hybrid network should be considered as temporary and used only as part of a comprehensive upgrade program.

## Phase 1 - Installation of Hybrid Network Cards in a BS Network

**i** Inform responsible persons on site that the fire alarm system is being powered down and there will be no automatic detection of fire in affected areas while upgrade work is being done, so that alternative fire procedures are in place.

The illustration shows a BS Network, where panels/node are fitted with Hybrid Network Card to run EN network protocol

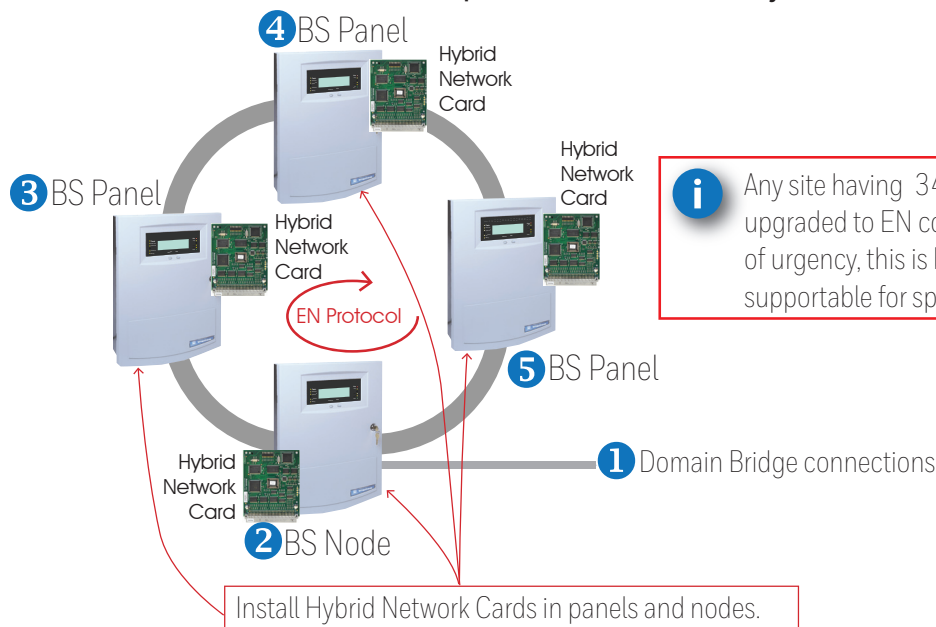

**i** Any site having 3400 panels, then they must be upgraded to EN compliant panels as a matter of urgency, this is because they are no longer supportable for spares.

- Disconnect any Domain Bridge connections **1**.
- Upgrade the BS Terminal node **2**.
  - Power down - disconnect the battery and power-down mains supply.
  - Replace the installed BS Network card with a Hybrid Network Card
  - Power up - reconnect the battery and power-up mains supply.
- Similarly upgrade the remaining panels/nodes in wiring order, using the above example it will be in a sequence from panel **3** to panel **5**.

**i** Once the Hybrid BS EN network is powered up there will be a warning displayed on each panel/node to indicate the Hybrid software is installed. The warning given is: "Node 0 lost".

During the upgrade process if the "system" is not working correctly then it is necessary for the whole Domain, that is all the panels and nodes in a secure Network to be upgraded in one session.

- Once the Hybrid Network Cards are installed in panels/nodes reconnect the Domain bridge connection **1**.
- If WinMag(s) are connected then ensure they are converted from BS to EN operation, see instructions supplied with WinMag.

## Phase 2 - Upgrade to compliant EN Panels / nodes

As part of a phased upgrade plan all the BS panels/nodes must be upgraded to EN compliant panels/nodes. Upgrade one panel/node at a time.

**All panels/nodes in a single network must be upgraded to EN over a time frame not exceeding 3 years.**

**i** Inform responsible persons on site that the fire alarm system is being powered down and there will be no automatic detection of fire in affected areas while the upgrade work is being done, so that alternative fire procedures are in place.

All BS Panels/Node are upgraded to EN Panels/Node.  
(Hybrid Network Cards are replaced with EN Network Cards)

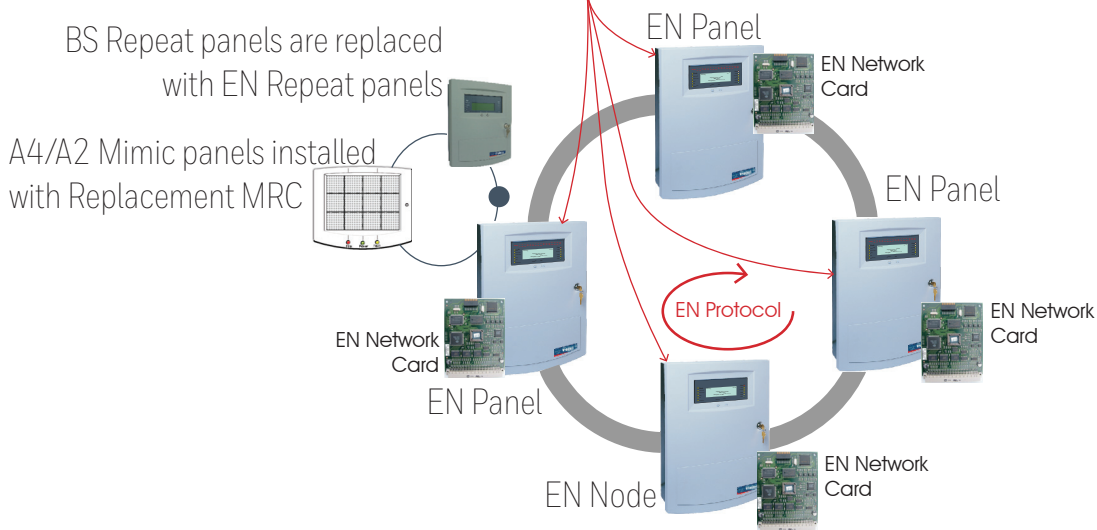

a) Using the Commissioning Tool retrieve the system configuration from a BS Vigilon panel/node to be upgraded.

b) Use the retrieved BS configuration file and convert the cause and effect to EN using the Configuration Conversion Tool. Ensure the Domain number is added before conversion to EN.

c) Completely power-down the panel/node to be upgraded, by disconnecting its battery and mains supplies.

d) Install replacement panel/node and fit required EN cards, as identified during site survey in Phase 1. If using the same Network card then replace the V3.xx chip with the V4.xx chip supplied using a suitable tool.

e) Install EN Repeat panels and Replacement MRCs in A4/A2 Mimic panels on loops as identified during site survey in Phase 1.

f) Power-up the EN Repeat/Mimic panels on loop circuits by reconnecting their battery and mains supplies.

g) Power up the panel /node, by reconnecting its battery and mains supplies..

h) Retrieve the modified system configuration file saved in 'step b)' to the panel/node.

i) Perform basic commissioning tests to verify the configuration changes.

h) Repeat steps a) to i) for the next wired panel/node to be upgraded.

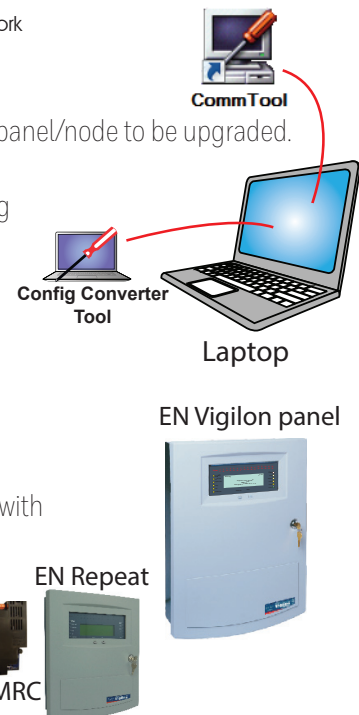

## Hybrid BS EN Network operational differences



**A Hybrid BS EN network is more complex and has to manage events, commands and replies over different protocols so there are operational differences.**

- There are some non-critical EN events that BS panels in a Hybrid BS EN Network will not interpret, these will be shown as 'Unrecognised events'. However Winmag system will be able to identify and display all events.
- All BS Panels in a Hybrid network will treat all received 'Disablement' events as 'Warning' events.
- The global 'Warning' count shown on BS panels may be different to that displayed on an EN panel and at the Winmag system. Winmag system will include disablements events.
- The fault count shown on BS panels is likely to be different as it does not include some 'Warning' events that were recategorised as faults in an EN system.
- When 'Disablement' events information is requested from a BS panel these are replied as 'Warning' events.
- Sounder events are not treated differently for fault and disablement indications at a BS panel..



At the end of their useful life, the packaging, product and batteries should be disposed of via a suitable recycling centre and in accordance with national or local legislation.



**WEEE Directive:**  
At the end of their useful life, the packaging, product and batteries should be disposed of via a suitable recycling centre.  
Do not dispose of with your normal household waste.  
Do not burn.

Honeywell Gent reserves the right to revise this publication from time to time and make changes to the content hereof without obligation to notify any person of such revisions of changes.

<b>Honeywell</b> GENT	Hamilton Industrial Park, Waterside Road, Leicester LE5 1TN, UK.	Website: <a href="http://www.gent.co.uk">www.gent.co.uk</a>
	Telephone: +44 (0) 116 246 2000	Tech. Support <a href="http://www.gentexpert.co.uk">www.gentexpert.co.uk</a>
		Fax (UK) +44 (0) 116 246 2300