

# Single Mode Fibre Network Card (VIG-NC-SMF)

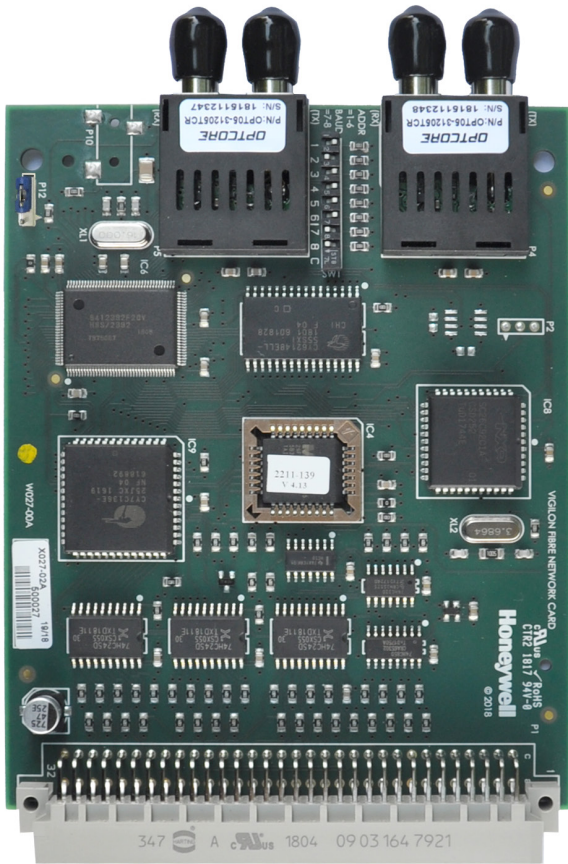

### Technical Data

Overall size	144 mm height, 100 mm width, 14 mm depth
Baud	19.2K, 38.4K, 115.2K & 230.4K configurable by switches 7 and 8 on SW1
Fibre Optics	Connection is by means of the ST sockets on the SM Fibre Network card.
Optical Fibre Cable	Single Mode 9/125 $\mu$ m LSZH 01855M, G652 compliant. Fire rating: LSZH rated (Low-Smoke, Zero-Halogen) Fibre classification : OS1 The Optical Fibre Cable must be installed in accordance with the recommendations of BS5839 Part 1 with adequate mechanical protection.
Attenuation range	Attenuation 3dB to 15dB with 9/125 $\mu$ m cable Operating wavelength : 1310 nm & 500Kb/s
Weight	100g (approximate)
Operating temperature	0°C to +45°C
Storage temperature	-10°C to +55°C
Relative humidity	Up to 90% (non condensing)

The Single Mode Fibre Network Card (VIG-NC-SMF) allows fast message passing to the network over distance up to 20km between Vigilon Plus panels (VIGPLUS-24, VIGPLUS-72) / Network Nodes (VIGPLUS-NODE).

The Single Mode Fibre Network card is designed to plug into the backplane of a panel or node in a dedicated slots. Fibre optic cables connect directly to the sockets on the card.

The Single Mode Fibre Cards can be configured via a link P12 for Domain or Domain Ring function in a secure EN54 Vigilon Plus network.

### Compatibility

The Single Mode Fibre Network Card is compatible with Main Control Card (MCC) at V4.56 or later.

**Domain:** Up to 31 Vigilon Plus panels and Network Nodes can be connected in a secure loop. There can be up to 20Km Fibre Optic cable distance between panel and node.

**Domain Ring:** Up to 64 smaller networks (each having up to 31 panels) can be connected to form a secure domain ring. The Fibre optic cable distance between nodes of the smaller networks can be up to 20Km. The entire system can have up to 200 panels/nodes.

### Single Mode Fibre Card connections and settings

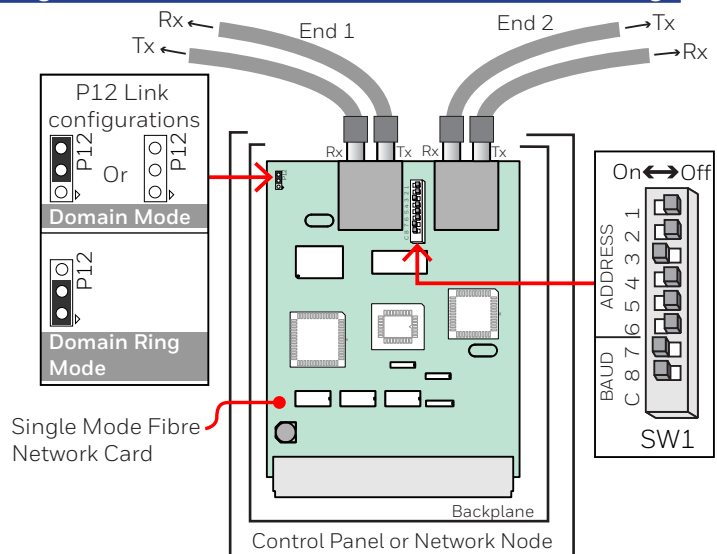

Ensure the patch leads are of the correct length and are routed correctly for direct connection to the Single Mode Fibre Network Card.

### SW1 switches to set address and baud rate

Address	Panel/Node Address Switch setting						Baud rate Switch settings		Baud
	1	2	3	4	5	6	7	8	
64	off	off	off	off	off	off	off	off	19200
1	on	off	off	off	off	off	on	off	38400
2	off	on	off	off	off	off	off	on	115200
3	on	on	off	off	off	off	on	on	230400
4	off	off	on	off	off	off			
63	on	on	on	on	on	on			
	- Factory setting								

# User Guide

## Backplane Card Slot locations and wiring

Vigilon Plus Control Panel or Network Node

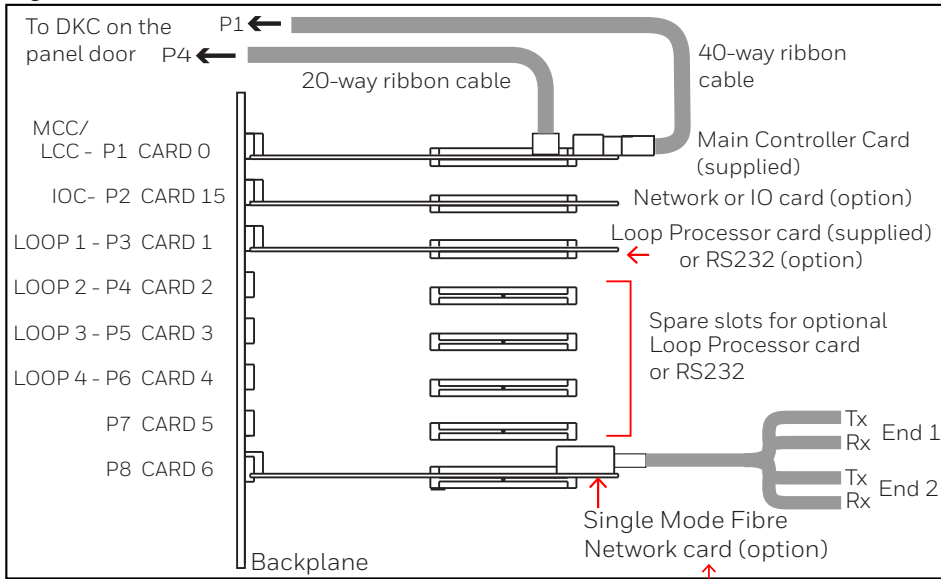

Loop Processor Cards are not applicable for Network node

**DO NOT** bend Fibre cable beyond the radius recommended by the cable manufacturer.

Use suitable attenuators fitted inside the patch panel for shorter fibre cable lengths.

Fibre cable must exit one Network card on Transmit (Tx) and enter the next Network card on Receive (Rx).

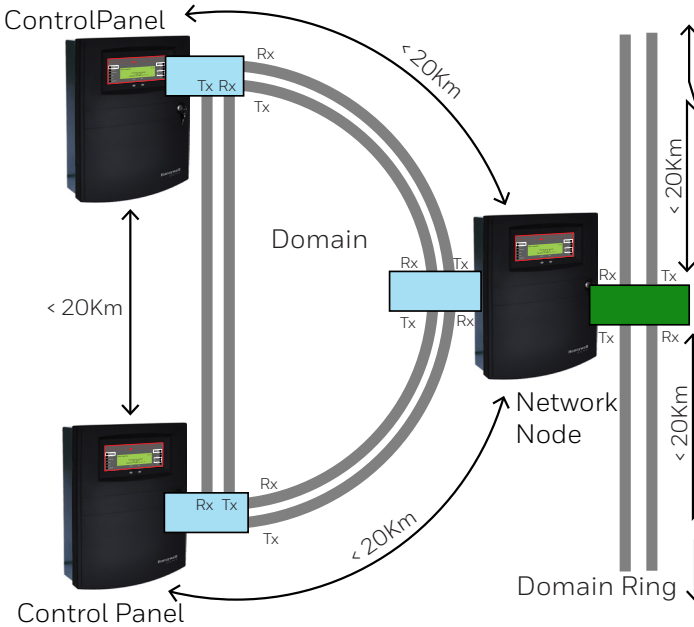
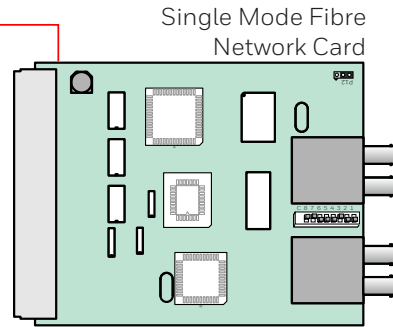

Cable distances may be extended using additional Network node.

- Key
- Single Mode Fibre Network card for Domain Ring
  - Single Mode Fibre Network card for Domain

**It is not permissible to mix single-mode and multi-mode on Domain and Domain ring Networks.**

At the end of their useful life, the packaging, product and batteries should be disposed of via a suitable recycling centre and in accordance with national or local legislation.

**WEEE Directive:** At the end of their useful life, the packaging, product and batteries should be disposed of via a suitable recycling centre. Do not dispose of with your normal household waste. Do not burn.

Honeywell Gent reserves the right to revise this publication from time to time and make changes to the content hereof without obligation to notify any person of such revisions of changes.

	Hamilton Industrial Park, Waterside Road, Leicester LE5 1TN, UK.	Website: <a href="http://www.gent.co.uk">www.gent.co.uk</a>
	Telephone: +44 (0) 203 409 1779	Tech. Support <a href="http://www.gentexpert.co.uk">www.gentexpert.co.uk</a>