

S-Quad Self-Test (S4T) range

Sensor, Sounder, Speech & Visual Alarm



These instructions are for the S-Quad SELF-TEST product range in white and black mouldings. It is available in Heat, Optical Heat and Dual optical heat detectors variants with sounder speech and VAD combinations. The Honeywell connected life safety services (CLSS) App allows an engineer to automatically test the operation of optical and heat with a detection device. Self-Test functionality is only available on the Vigilon loop in both the Vigilon plus and Compact plus panel variants with compatible firmware.



042xx/xx
(LPCB numbers)

042be/02
042bf/04
042bf/05
042ak/06
042ca/07
042ca/09
042ca/10
042bw/05
042bv/03
042bu/12
042bu/13

All LPCB approved Sensor STATES are listed in the 'Description and commissioning information' Part 2 of this document.

Information on minimum sound output levels to include polar dispersion is covered in a technical note TECH7018.033, available on request from manufacturer.

See section headed 'Visual Alarm Coverage' in part 2 of this document for data on Visual Alarm Devices coverage information.

Symbols on product



Protective Earth connection terminal.



The WEEE symbol. It indicates the product is to be recycled and not thrown away.



The CE compliance logo. This product is in conformity with the relevant European Union harmonisation legislation.



The RoHS compliance logo. The RoHS directive restricts the use of certain hazardous substances commonly used in electronic and electronic equipment.



The UKCA (UK Conformity Assessed) marking is a new UK product marking that is used for goods being placed on the market in Great Britain (England, Wales and Scotland).

Loop loading

The 'Battery Standby and Loop Load calculator' tool is available via Gentexpert website. The tool must be used to accurately determine the loop loading, cable length for lumped loads and to ensure the devices installed on each loop are within the maximum allowed and will meet the control panel's standby requirement.

Technical Data

Operating voltage	35V - 48V
Weight	Sensor head only 152 g (with Standard base - 212 g)
Dimensions	Sensor head: 117 mm diameter by 63 mm height (With Base the height increases to 70 mm)
IP rating	IP21C
Enclosure	Terluran GP-35 (ABS) for outer housing
Colour	White RAL 9010 Black RAL 9005
Approval	LPCB approval pending
Storage Temperature	-20 °C to +65 °C
Ambient operating temperature	-10 °C to +50 °C
Relative Humidity	95 % non condensing (+5 °C to +45 °C)
Air Velocity for fire detection	0 to 20 m/s
Self-Test (ST) operation:	
Smoke Self-Test temperature range	0 to 40 °C expected
Heat Self-Test temperature range	0 to 40 °C expected
Maximum number of optical tests	60 (with an expected maximum of 4 self tests and 4 tests/year for 14 years).
Maximum number of heat tests	100 (expected maximum 4 tests and 4 tests/year for 20 years)
Air Velocity around device	0 to 1.5 m/s
Bluetooth range	10m
Heat (H)	EN54-5 : 2017 + A1 : 2018
Optical (O)	EN54-7 : 2018
Dual Optical (O ²)	EN54-7 : 2018
Sounder (S)	EN54-3 : 2001 + A1 : 2002 + A2 : 2006 EN54-3 : 2014 + A1 : 2019
Visual Alarm Device (VAD)	EN54-23 : 2010
Input/Output devices connected to transmission path	EN54-18 : 2005
Short circuit isolator	EN54-17 : 2005 (section 4.8) data: Vmax 48 V IC max 0.8 A Vnom 40 V IS max 1.25 A Vmin 35 V IL max 50 uA Vso max 16 V Zc max 0.13 Ω Vso min 8 V
Sounder current	2 mA average and 4.5 mA maximum in Turbo mode (Refer to Battery Standby and Loop Load Calculator Tool.)

Product range

Part number	Description	Markings
S4T-720	S4 Self-Test Heat Sensor	H
S4T-710	S4 Self-Test Optical Heat Sensor	OH
S4T-711	S4 Self-Test Dual Optical Heat Sensor	O ² H
S4T-780-S	S4 Self-Test Heat Sensor Sounder	HS
S4T-770-S	S4 Self-Test Optical Heat Sensor & Sounder	OH/S
S4T-771-S	S4 Self-Test Dual Optical Heat Sensor & Sounder	O ² H/S
S4T-711-V	S4 Self-Test Dual Optical Heat Sensor & Voice Sounder	O ² H/VS
S4T-711-VAD-HPR	S4 Self-Test Dual Optical Heat Sensor & High Power Red VAD	O ² H/RVAD-HP
S4T-720-V-VAD-HPR	S4 Self-Test Heat Sensor, Voice Sounder & High Power Red VAD	H/VS/RVAD/HP
S4T-711-V-VAD-HPR	S4 Self-Test Dual Optical Heat Sensor, Voice Sounder & High Power Red VAD	O ² H/VS/RVAD-HP
S4TB-711-V-VAD-HPR	S4 Self-Test Black Dual Optical Heat Sensor, Voice Sounder & High Power Red VAD	O ² H/VS/RVAD-HP

Associated products

S4-700	Base (for all Self-Test Sensors)
S4BK-700	Black Base for Black S-Quad Self-Test
S4-705	White IP21C plate
S4BK-705	Black IP21C plate
805589	Sensor dust cover (50 pack)
805580	Removal tool kit (supplied with Dust Cover Remover part)
805576	Label plate (10 pack)

Siting

An S-Quad Self-Test device plugs into a dedicated Base that is installed in the protected premises. The Bases should be sited in locations as defined by the project plans and by BS5839 : Part 1 : 2017.

Do's and Don't



Follow recommendations detailed in section 22 relate to automatic fire detectors and section 16 relate to alarm sounders in BS5839 : Part 1 : 2017.

DO locate Visual Alarm Devices in accordance with Loss Prevention Council Code of Practice CoP 0001. <http://www.redbooklive.com/lps.jsp>

DO NOT use 'close fitted tamper-proof enclosure' over detector as it can restrict airflow to sensors and prevent early detection of smoke and heat

DO NOT locate smoke detectors where products of combustion may be present such as in kitchens, garages, furnace rooms, welding shops etc.

DO NOT locate heat detectors above boilers or heaters or where the temperature is normally very high or liable to sudden fluctuations.

DO NOT locate smoke or heat detectors: -

- In dusty or dirty environment
- Near heating or air-conditioning grilles
- Outdoors in stables, sheds etc
- In excessively damp areas
- In dead air spaces at the junctions of ceilings and walls
- At ceiling locations where a 'thermal barrier' may exist.

Mounting

Cable

It is recommended that only screened 2 core (1.5 mm² minimum to 2.5 mm² maximum) fire rated cable are used to wire the main loop circuit. Refer to the panel installation manual for list of approved cables.



Multi-core cable such as 4-core or more core cable must not be used for Loop circuit wiring.

Spur circuit off main loop circuit are allowed from certain devices, such as T breaker, Mains powered interface unit, Mains switching interface unit, Mimic panel and Loop Repeat panel.

Metal back box

A metal back box must be used for base mounting. The earth continuity must be maintained throughout the whole loop circuit. The earth must be securely connected to the back box.

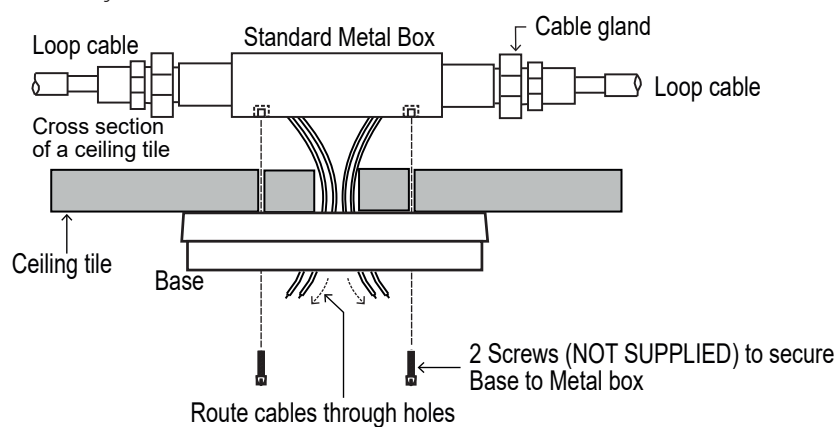

Wiring

Tamper-resistance base

The S-Quad S4T range include a tamper-resistant capability that prevents their removal from the base without the use of a tool. Refer to the base manual for details on making use of this capability.

In - Out wiring to bases

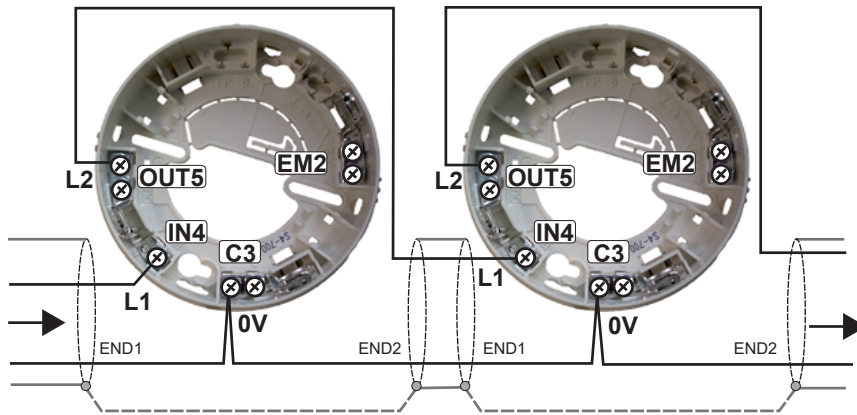

Programmable input/output

All S-Quad Self-Test devices can be configured as either monitored input monitored output or unmonitored output. The factory setting of the programmable input / output is unmonitored output, to drive an external repeat LED without a series resistor. There is a maximum cable length limit of 15 metres from the base to the external I/O Unit.

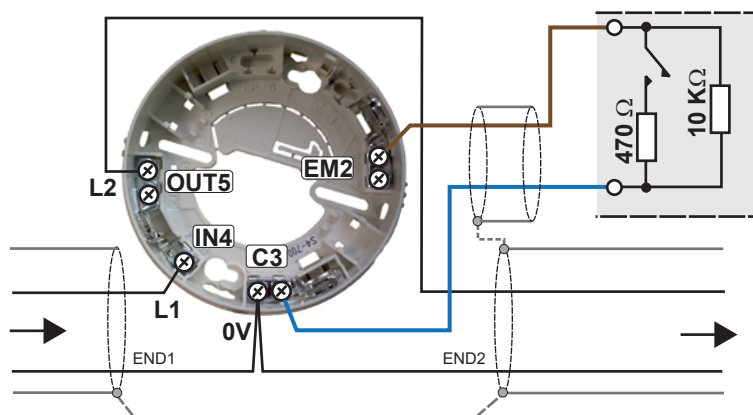
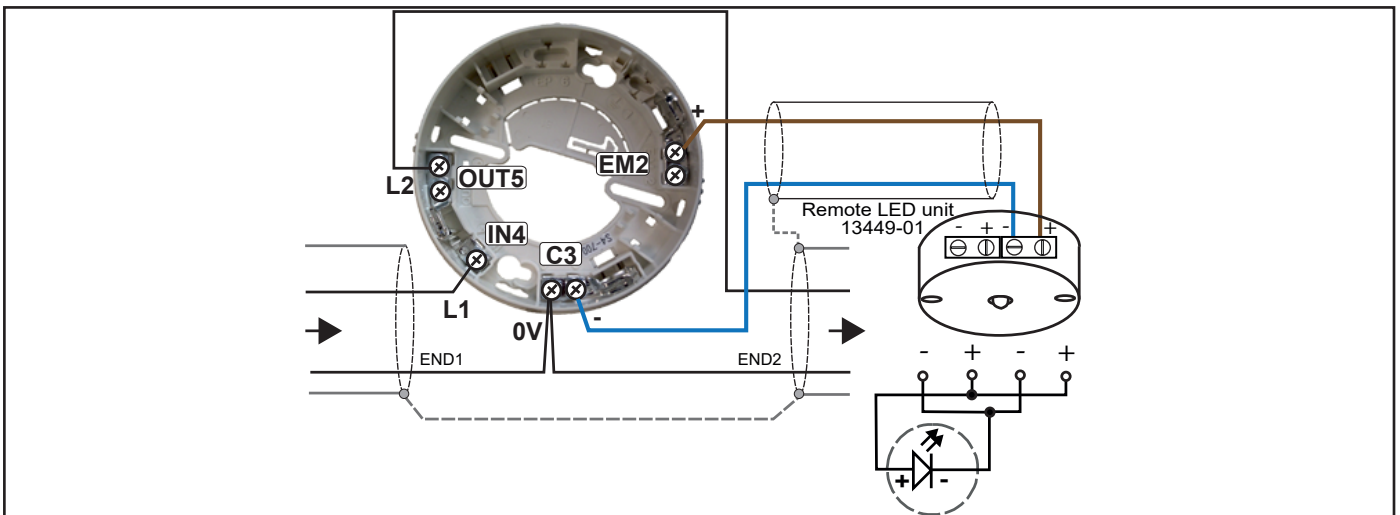

The input can accept signals such as fire, non fire or fault, these are configured during commissioning. As a fire input it is possible to connect a conventional Manual Call Point (non UK application only) with a series resistor of value 470 Ohms coupled with an end-of-line 10K Ohms resistor. In this case the fire input is fully monitored for open or short circuit faults. The input can be setup as a non-fire or fault input using a similar arrangement with series and parallel resistors as shown. It is possible for such an input to trigger a command that is configured to action an output elsewhere in the system to control plant equipment such as the ventilation system.

Tools

An extractor tool allows removal and fitting of the device head into the base. By fitting a screw-on adaptor, the tool can be used to remove the sensor dust cover.

To remove a device using tool

Fit the tool onto the device. Turn device anticlockwise until it stops and then remove the device from the base.

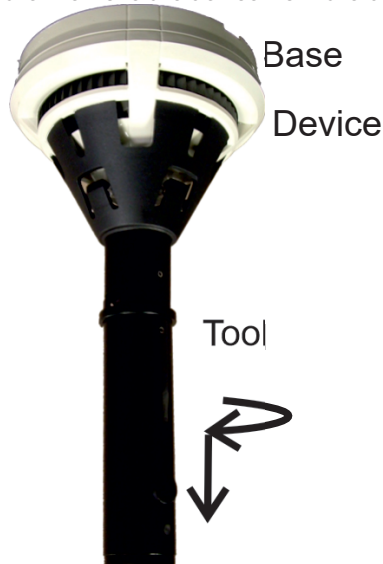

To fit the dust cover using tool

Place the dust cover onto the tool inside the cradle. Offer the cover to the device, locate and push to fit it onto the assembly. Withdraw the tool when the dust cover is in place.



To fit a Device using tool

Fit the device on to the tool. Offer device to base and rotate clockwise until it moves upwards on to the base and rotate it again until it clicks and goes no further, the lines on the base and device will align.

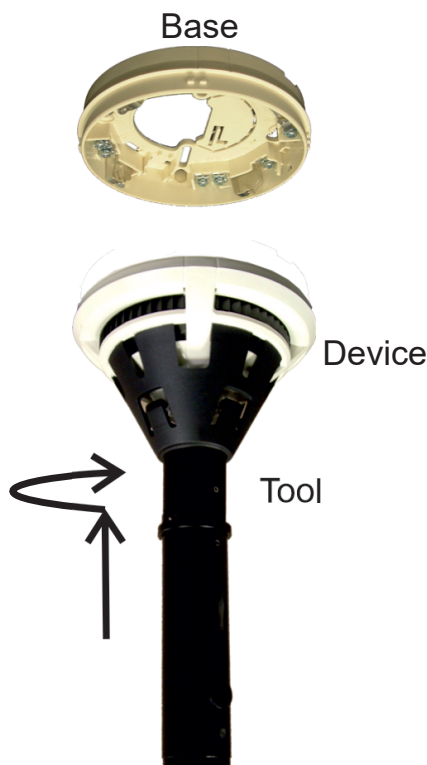

To remove the dust cover using tool

A dust cover remover tool must be fitted to the main tool to extract the dust cover. Press the pad of the dust cover remover tool onto the dust cover, this creates an air tight grip, to allow the cover to be pulled off from the device.



Semi-flush fixing kit (S4-FLUSH)

The Semi Flush fixing kit is only applicable for S-Quad Self-Test device. A device can be semi-flush mounted to a ceiling tile to an approximate depth of 20mm, which is slightly deeper than the base assembly. To semi-flush mount the special housing supplied in the kit must be used, which consists of a main assembly and a trim ring.

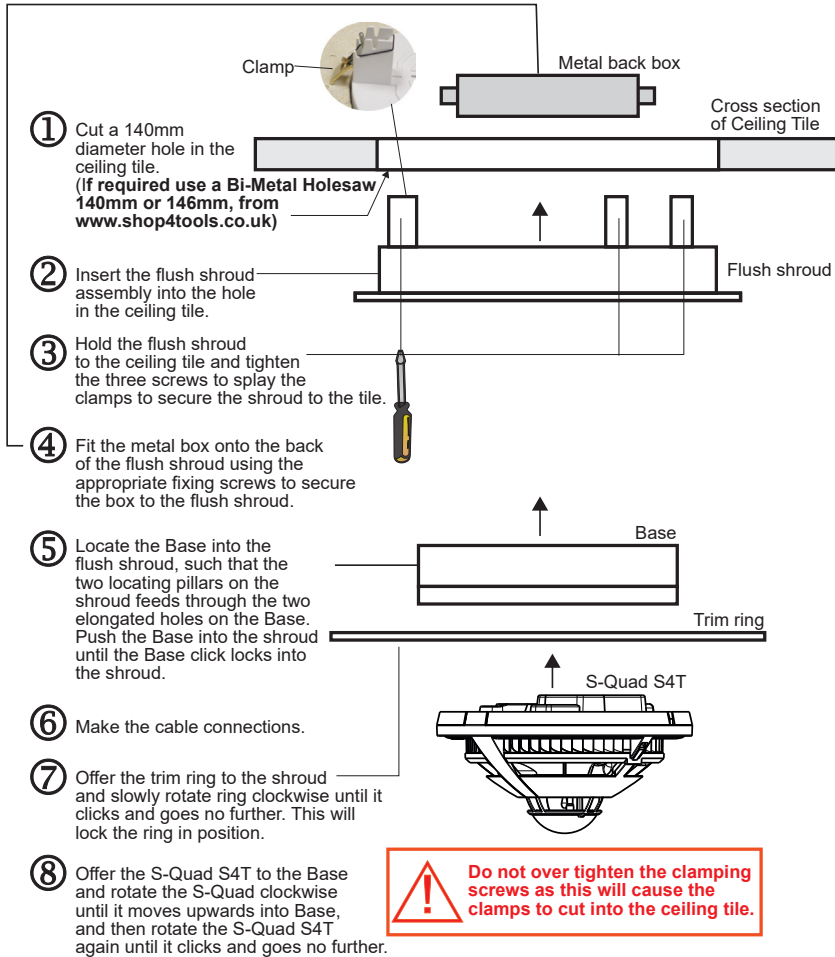

Technical data

Weight	164 g with trim ring
Dimensions	174 mm diameter by 50mm depth
Enclosure	ABS
Colour	RAL 9010
Storage Temperature	-20 °C to +70 °C
Ambient temperature	-10 °C to +50 °C
Relative Humidity	95 % non condensing (+5 °C to +45 °C)

Testing Self-Test Sensors

Sensors must be tested after first installation and during periodic maintenance. The BS5839 : Part 1 recommends that all sensors are tested for correct operation.

Preparation

Ensure sensor dust cover have been removed before carrying out a Self-Test.

Communication to site occupants

Before undertaking any of these tests ensure:

- All affected personal on site are informed via a responsible person that the fire alarm system is being tested.
- Where there is a link to an alarm receiving centre, the appropriate action is taken to ensure they are informed that tests are being carried out on the system.

Self-Test

This is a functional test of the optical sensor (and/ or heat sensor), followed by a smoke entry test, which checks if the sensor is masked, such as where the dust cover is not removed.

The heat sensor is tested by heating the thermistor (temperature measuring element), and checking for the correct thermal response.

The smoke sensor is tested by a controlled amount of smoke directed into the sensing chamber which tests the optical chambers response to real smoke.

A small fan within the device then pushes the smoke out of the detection chamber into the atmosphere thru the smoke entry point of the device (smoke entry test).

It is normal to hear a noise from the fan during the self-test operation. This noise will differ from device to device and this is perfectly normal.

Overview of Self-Test and Inspection

Here is an overview steps of the Self-Test and inspection:



- Panel must be placed in Service mode and there are two options On or On with BLE. On with BLE activates the bluetooth beaconing on all devices on the panel.
- Initiate Self-Test.
- Device(s) are tested for smoke entry and heat automatically.
- Device Pass / Fail is processed and status displayed at the Vigilon panel.
- This information is then sent to the cloud and mobile app via the Panel connection to a Gateway.
- If the devices were placed in beaconing mode they can be discovered by the mobile App when performing the visual inspection. The device with the strongest signal will appear at the top of the test session in the App and is defined with a dark blue bar on the left hand side of the device card. Any other devices within bluetooth range can be seen with a light blue bar on the left hand side of the device card. To pass the visual inspection swipe right on the device card. This will record the visual inspection has been performed with bluetooth verification.
- If the device does not pass the visual inspection, it can be failed by clicking on the device card. Once in the device card information you can enter corrective actions and test comments, to help identify why it did not pass.
- All other information above is captured and stored in the cloud.
- A compliance Report can be generated providing all these details.
- Report can be viewed by registered users of App and also viewed using CLSS Web portal.

Enabling Self-Test

Self-Test is a licensed feature, please refer to your CLSS account on how to activate and pay for self-test.



Additional features such as the Purge & Anti-Mask test will require a Self-Test license.

 0832 22	 2831 22																								
<p>Gent by Honeywell Manufactured by: Honeywell Life Safety Systems-Romania Street: Str. Salcamilor 2 bis- Lugoj</p> <table border="0"> <thead> <tr> <th style="text-align: left;">DoP</th> <th style="text-align: left;">Product No.</th> </tr> </thead> <tbody> <tr><td>134-CPR-2022</td><td>S4T-720</td></tr> <tr><td>134-CPR-2022</td><td>S4T-710</td></tr> <tr><td>134-CPR-2022</td><td>S4T-711</td></tr> <tr><td>134-CPR-2022</td><td>S4T-780-S</td></tr> <tr><td>134-CPR-2022</td><td>S4T-770-S</td></tr> <tr><td>134-CPR-2022</td><td>S4T-771-S</td></tr> <tr><td>134-CPR-2022</td><td>S4T-711-V</td></tr> <tr><td>134-CPR-2022</td><td>S4T-711-VAD-HPR</td></tr> <tr><td>134-CPR-2022</td><td>S4T-720-VAD-HPR</td></tr> <tr><td>134-CPR-2022</td><td>S4T-711-V-VAD-HPR</td></tr> <tr><td>134-CPR-2022</td><td>S4TB-711-V-VAD-HPR</td></tr> </tbody> </table>		DoP	Product No.	134-CPR-2022	S4T-720	134-CPR-2022	S4T-710	134-CPR-2022	S4T-711	134-CPR-2022	S4T-780-S	134-CPR-2022	S4T-770-S	134-CPR-2022	S4T-771-S	134-CPR-2022	S4T-711-V	134-CPR-2022	S4T-711-VAD-HPR	134-CPR-2022	S4T-720-VAD-HPR	134-CPR-2022	S4T-711-V-VAD-HPR	134-CPR-2022	S4TB-711-V-VAD-HPR
DoP	Product No.																								
134-CPR-2022	S4T-720																								
134-CPR-2022	S4T-710																								
134-CPR-2022	S4T-711																								
134-CPR-2022	S4T-780-S																								
134-CPR-2022	S4T-770-S																								
134-CPR-2022	S4T-771-S																								
134-CPR-2022	S4T-711-V																								
134-CPR-2022	S4T-711-VAD-HPR																								
134-CPR-2022	S4T-720-VAD-HPR																								
134-CPR-2022	S4T-711-V-VAD-HPR																								
134-CPR-2022	S4TB-711-V-VAD-HPR																								
<p>EN54-3:2001 + A1:2002 + A2:2006, EN54-3 : 2014 + A1 : 2019, EN54-5:2017 + A1:2018, EN54-7:2018, EN54-17:2005, EN54-18:2005, EN54-23:2010</p> <table border="0"> <tbody> <tr><td>S4T-720</td><td>(EN54-5,17,18)</td></tr> <tr><td>S4T-710</td><td>(EN54-5,7,17,18)</td></tr> <tr><td>S4T-711</td><td>(EN54-5,7,17,18)</td></tr> <tr><td>S4T-780-S</td><td>(EN54-3,5,17,18)</td></tr> <tr><td>S4T-770-S</td><td>(EN54-3,5,7,17,18)</td></tr> <tr><td>S4T-771-S</td><td>(EN54-3,5,7,17,18)</td></tr> <tr><td>S4T-711-V</td><td>(EN54-3,5,7,17,18)</td></tr> <tr><td>S4T-711-VAD-HPR</td><td>(EN54-5,7,17,18,23)</td></tr> <tr><td>S4T-720-V-VAD-HPR</td><td>(EN54-3,5,17,18,23)</td></tr> <tr><td>S4T-711-V-VAD-HPR</td><td>(EN54-3,5,7,17,18,23)</td></tr> <tr><td>S4TB-711-V-VAD-HPR</td><td>(EN54-3,5,7,17,18,23)</td></tr> </tbody> </table> <p style="text-align: center;">Intended for use in fire detection and fire alarm systems</p> <p style="text-align: center;">Refer to DoP 134-CPR-2022, for level or class of performance declared, for details see website www.gent.co.uk</p>		S4T-720	(EN54-5,17,18)	S4T-710	(EN54-5,7,17,18)	S4T-711	(EN54-5,7,17,18)	S4T-780-S	(EN54-3,5,17,18)	S4T-770-S	(EN54-3,5,7,17,18)	S4T-771-S	(EN54-3,5,7,17,18)	S4T-711-V	(EN54-3,5,7,17,18)	S4T-711-VAD-HPR	(EN54-5,7,17,18,23)	S4T-720-V-VAD-HPR	(EN54-3,5,17,18,23)	S4T-711-V-VAD-HPR	(EN54-3,5,7,17,18,23)	S4TB-711-V-VAD-HPR	(EN54-3,5,7,17,18,23)		
S4T-720	(EN54-5,17,18)																								
S4T-710	(EN54-5,7,17,18)																								
S4T-711	(EN54-5,7,17,18)																								
S4T-780-S	(EN54-3,5,17,18)																								
S4T-770-S	(EN54-3,5,7,17,18)																								
S4T-771-S	(EN54-3,5,7,17,18)																								
S4T-711-V	(EN54-3,5,7,17,18)																								
S4T-711-VAD-HPR	(EN54-5,7,17,18,23)																								
S4T-720-V-VAD-HPR	(EN54-3,5,17,18,23)																								
S4T-711-V-VAD-HPR	(EN54-3,5,7,17,18,23)																								
S4TB-711-V-VAD-HPR	(EN54-3,5,7,17,18,23)																								

	<p>At the end of their useful life, the packaging, product and batteries should be disposed of via a suitable recycling centre and in accordance with national or local legislation.</p>
--	---

	<p>WEEE Directive: At the end of their useful life, the packaging, product and batteries should be disposed of via a suitable recycling centre. Do not dispose of with your normal household waste. Do not burn.</p>
--	--

Honeywell Gent reserves the right to revise this publication from time to time and make changes to the content hereof without obligation to notify any person of such revisions of changes.

	Gent by Honeywell (Novar Systems Limited), Building 5 Carlton Park, King Edward Avenue, Narborough, Leicester, LE19 0AL, UK	
	Telephone: +44 (0) 203 409 1779	Website and Tech. Support: https://buildings.honeywell.com/gb/en/brands/our-brands/gent

S-Quad Self-Test (S4T) range

Sensor, Sounder, Speech & Visual Alarm

Description

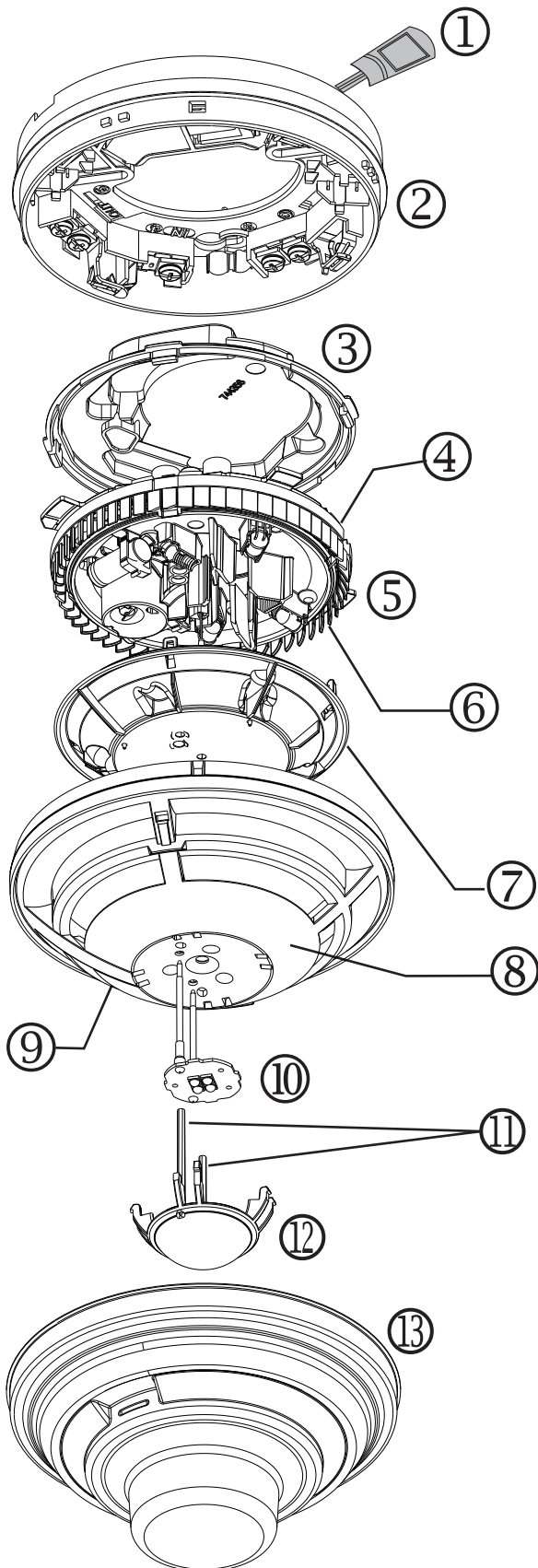

①	Base Label
②	Base
③	PCB Cover
④	PCB
⑤	Optical Chamber and sounder horn assembly
⑥	Baffle ring: Black - Sensor and/or VAD White - Sensor with Speech and/or Sounder
⑦	Insect mesh assembly
⑧	Outer housing
⑨	Sensor marking
⑩	Visual Alarm
⑪	Light pipes
⑫	Lens Cap
⑬	Dust Cover

Base

The base has terminals for external cables to allow it to be electrically connected to the panel loop circuit and to the monitored input or output circuit. Any S-Quad Self-Test device can be plugged into a base.

Base labels

An optional label (Part No: 805576) can be fitted to the base. The label can be marked up with device location information.

Lock

Refer to the instructions supplied with the Base for information on how to lock the Sensor to Base.

Indicators

The S-Quad Self-Test has a red LED that gives an indication in the event of a fire. The LED can be configured to flash periodically, as an 'in operation' confirmation, this indication is given system-wide at all S-Quad Self-Test devices.

Dust Cover

A dust cover is supplied with the S-Quad Self-Test to prevent dust from building work contaminating the sensor. The cover is removed prior to the commissioning of the fire alarm system.

Monitoring

Under normal conditions the S-Quad Self-Test devices are monitored regularly and the data is used to create a background performance record. When there is a potential event, the S-Quad Self-Test device will flag the control panel for attention. The control panel will take further readings from the device and compare all the measurements with patterns and rules to determine if it is a fire event.

Device functionality

All S-Quad Self-Test devices are monitored periodically to check if they are working correctly, an indication of a fault is given if there is a failure. For example the infrared signals through the optical chamber are regularly checked and the thermistor is checked for failure. The speech, VAD and sounder circuits are monitored for failure.

Heat sensor (H)

The heat sensing is provided by a thermistor ①. The temperature at which the device goes into fire is defined by the configuration settings in the control panel. The control panel also calculates any rate of rise elements required in the fire decision.

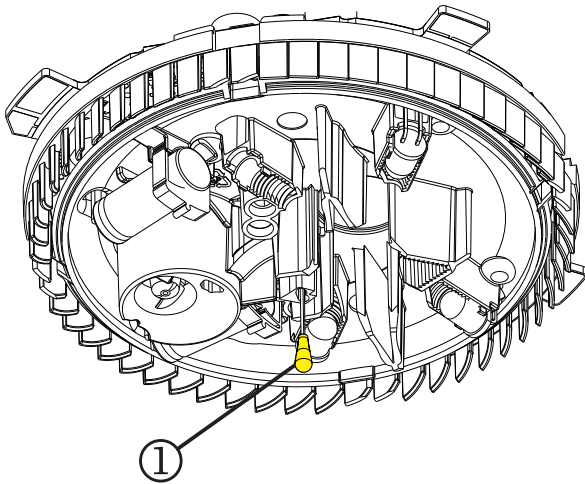

Dual Optical Sensor

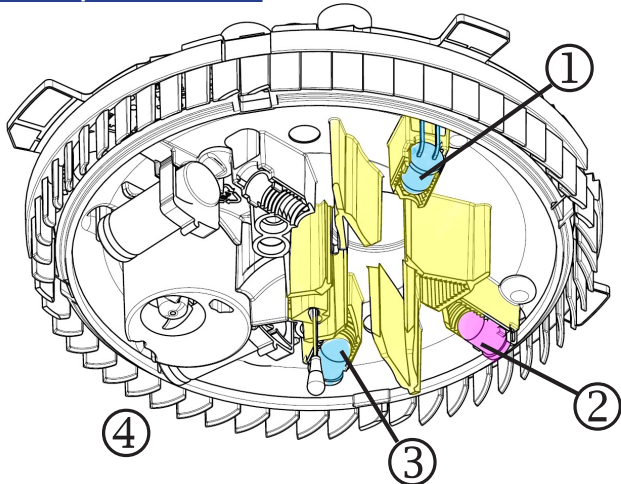

The optical sensing is performed by the dual angle optical chamber ④, which has two transmitting ① LED1 and ③ LED2, plus an infrared receiver ②. Normally measurements are taken at regular intervals at both angles of the chamber. The panel uses both readings to form a ratio. The ratio is used to compensate the optical sensor, producing a very flat response to different fire types. There are distinct bands of ratios that define the presence of types of smoke, dust or steam. The dual optical sensor is therefore able to discriminate between certain aerosol in the environment. Additionally to stop the sensor saturating with large false alarm signals the sensor incorporates an extended dynamic range. The sensor is therefore suitable for use in wider applications where steam and dust particles may occasionally be present.

Single Optical Sensor

The optical sensing is performed in the optical chamber using transmitting LED 1 ① and an infrared receiver ②. Measurements are taken at regular intervals. The control panel use these readings to detect the presence of smoke.

Self-Test

SMOKE Self-Test:

The self-testing of optical sensor is made possible by activating a paraffin aerosol (smoke) generator ①. A controlled amount of smoke is generated and then directed into the optical scatter chamber ③ by a variable speed fan ②. Analogue readings are sent back to the CIE to verify the correct optical response. For a Dual Optical Sensor, then the readings on both channels would be verified, see Dual Optical Sensor for explanation on how smoke is detected. To complete the optical self-test, a smoke entry test is performed. Smoke generation stops and the variable speed fan ② now increases its flow rate, in order to quickly draw clean-air/ambient air into the sensor to remove the smoke, via the smoke entry points. If the smoke entry into the smoke chamber is not impeded, then the analogue values measuring the optical smoke density quickly drop. The CIE checks for a fast decay rate of the analogue readings and a return to the ambient values, before the test can pass, ensuring no test smoke remains in the sensor.

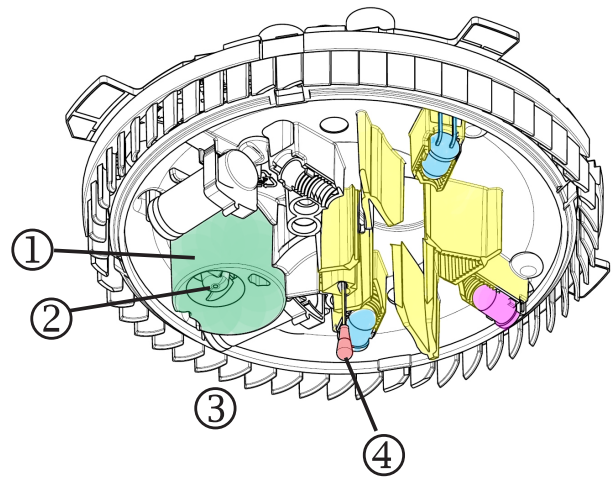

HEAT Self-Test

The self-testing of heat sensor is made possible by heating a thermistor ④ (this is the temperature measuring element of the heat sensor). During this heating period, the sensor sends analogue values back to the CIE, to verify the correct thermal response (change in level over a time period).

Sounder (S)



All outputs (sounder, voice or strobe) devices in the same sector will be synchronised to the same signal output. There is no option to be unsynchronised.

The sounder function is designed to meet the requirement of EN54 : Part 3. The EN54 : Part 3 average output from the sounder is 85dBA at 1m or 75dBA at 3m at a bedhead, making it suitable for installation in hotel bedrooms. The sounder can operate a turbo mode if configured during commissioning to provide further 3dB output. The sound outputs are based on the settings of the FABs and SABs at the panel that gives changing levels over 2 seconds duration in 8 time slots. The standard outputs are synchronised with the 34000 sounders and S3 devices installed in the same system.

A piezo disk within the S-Quad Self-Test assembly outputs the sound via a horn, which is constructed in the chamber moulding. The volume of the sound output can be individually set at the device, note that the sound level should not be set lower than 65dBA at 1m for standards compliance. The system prevents adjustment of volume down to zero. Another feature that can be configured is the soft start that ramps the sound volume gradually to the maximum level set at the device. The Sounder function is silently monitored for failure. An S-Quad Self-Test device with a white baffle identifies it as having Sound functionality.



The Sound Pressure Level on axis at 90° will typically be 92dB(A).

Tones

Signal 1 Intermittent tone 933 @ 1Hz

Signal 2* Alternating tone
High 933 Hz for 0.25 secs /
Low 700 Hz for 0.25 secs

Signal 3* High Tone - Continuous 933Hz

The Signals marked with an * are LPCB approved. The above tones are nominal only.

Speech (Sp)

The S-Quad Self-Test device Speech function is provided by stored messages on a flash memory chip within the assembly. The standard flash memory can hold up to 20 seconds of audio and additionally it holds local complex attention tones, such as the bell and DIN signals. Each signal output from an S-Quad Self-Test Speech device consists of an attention tone followed by a message. The attention tone can be a local complex tone or a panel tone, such as the standard 'nee naw' sound. The Speech function is silently monitored for failure.

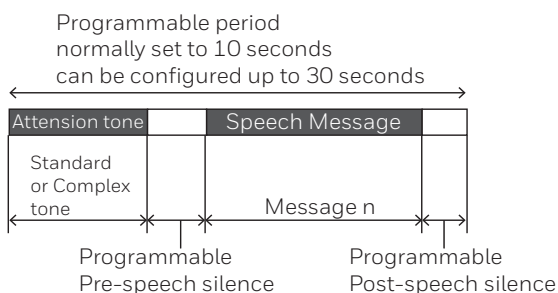

It is possible to reprogram factory set speech messages

There are four default messages in English plus a bell tone. However your system may carry special messages.

Messages

Default messages

Message 1	Bell tone	
Message 2	<i>Attention please this is an emergency please leave the building by the nearest available exit. (female voice)</i>	Signal 3
Message 3	<i>An incident has been reported in this building please await further instructions. (female voice)</i>	Signal 1
Message 4	<i>This is a test message no action is required. (female voice)</i>	Signal 0
Message 5 #	<i>This is a fire alarm please leave the building immediately by the nearest available exit. (male voice)</i>	Signal 2

Approved to EN54-3 Annex C.

Visual Alarm Device (S-Quad Self-Test VAD)

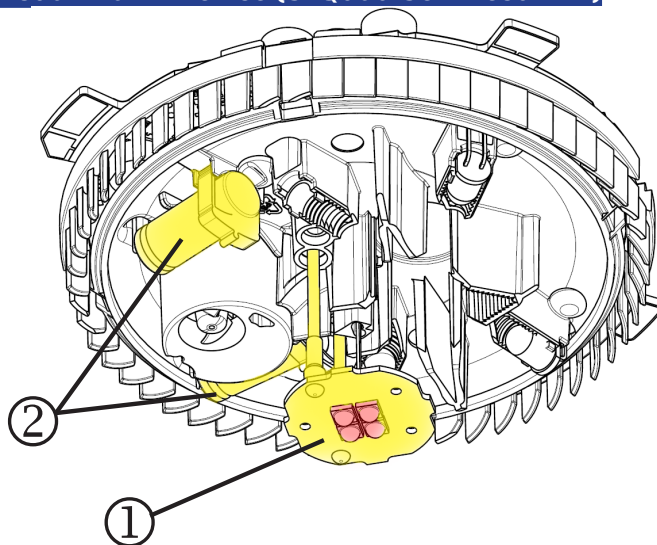

The Visual Alarm Device (VAD) utilises a high-power red LED ① that receives its power from super capacitors ② in the S-Quad Self-Test assembly. The high light output from the LED is made possible by the low impedance of the capacitor. The Visual Alarm is designed to meet requirements of EN54 Part 23 for installation on a ceiling. As factory set the Visual Alarm provides a pulsed output every 2s. The Visual Alarm is synchronised all S-Cubed VAD installed in the same system. The Equality Act 2010 recommends visual alarms S-Quad Self-Test, are installed in protected premises to warn occupants who are hard of hearing.



It is possible to set the flash rate with commissioning tools to 1s,2s,or 4s but only the 2s rate is compliant with EN54-23.

Device address allocation

Refer to the CIE manual 4188-856 for information on how devices are allocated addresses on a loop circuit.

Category 'C' Visual Alarm Coverage

What is Category 'C' (Ceiling-mounted) coverage volume

A ceiling-mounted Visual Alarm Device (VAD) covers a cylindrical volume with a minimum effective illuminance of 0.4 Lux. The coverage volume is stated as:

C-x-y

- where C is the ceiling mounted category
- 'x' is the maximum mounting height in metres and
- 'y' is the maximum diameter in metres.

The 'C' category is currently restrictive and only allows mounting heights to be specified as 3, 6 or 9 metres. This diagram shows how to relate the cylindrical volume to a square spacing volume. Note the diameter 'y' is divided by 1.414.

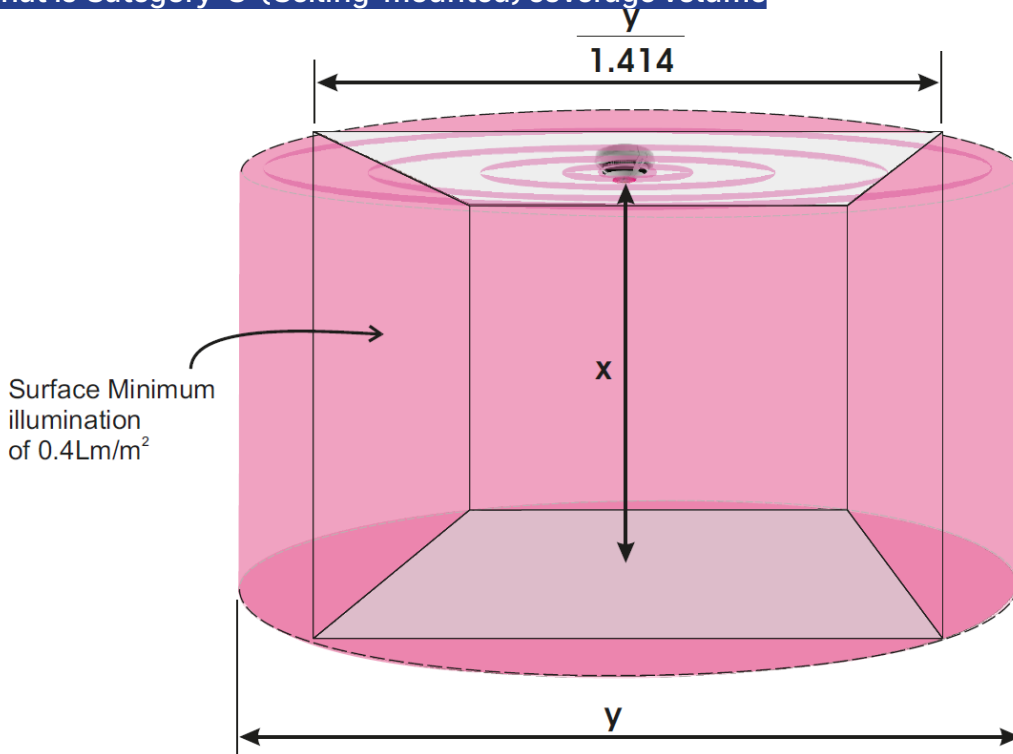
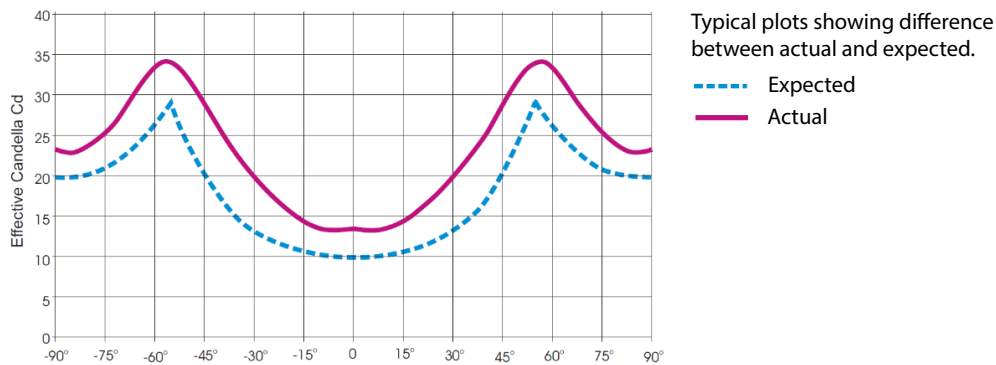

Fig. A Category 'C' Coverage

Example

A C-3-14 could be mounted at 3m and have a square spacing of 9.9m; however the recommendations of CoP 0001 must be applied.



Category 'O' Visual Alarm Coverage

What is Category 'O' (intended ceiling-mount) coverage volume

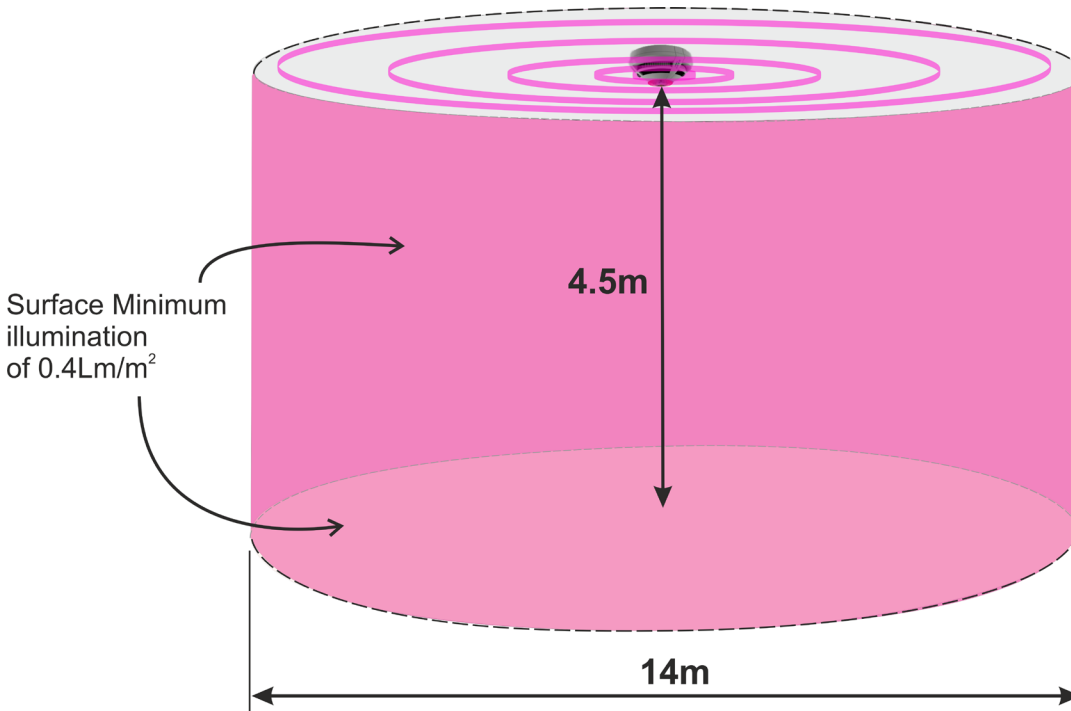

Fig. B Category 'O' Coverage height 4.5m by 14m diameter

Mounting position
The VAD is an integral part of the device and has the same mounting arrangement as the smoke sensor. It is mounted in its base and intended for ceiling mount.

Orientation
The VAD must be mounted on a flat surface but is not directionally dependant, so it can be rotated.

Mounting height
The VAD has a maximum mounting height as defined by the Category 'O' specification and CoP0001, see pages 13 and 14.

Volume coverage
See Fig B & C.

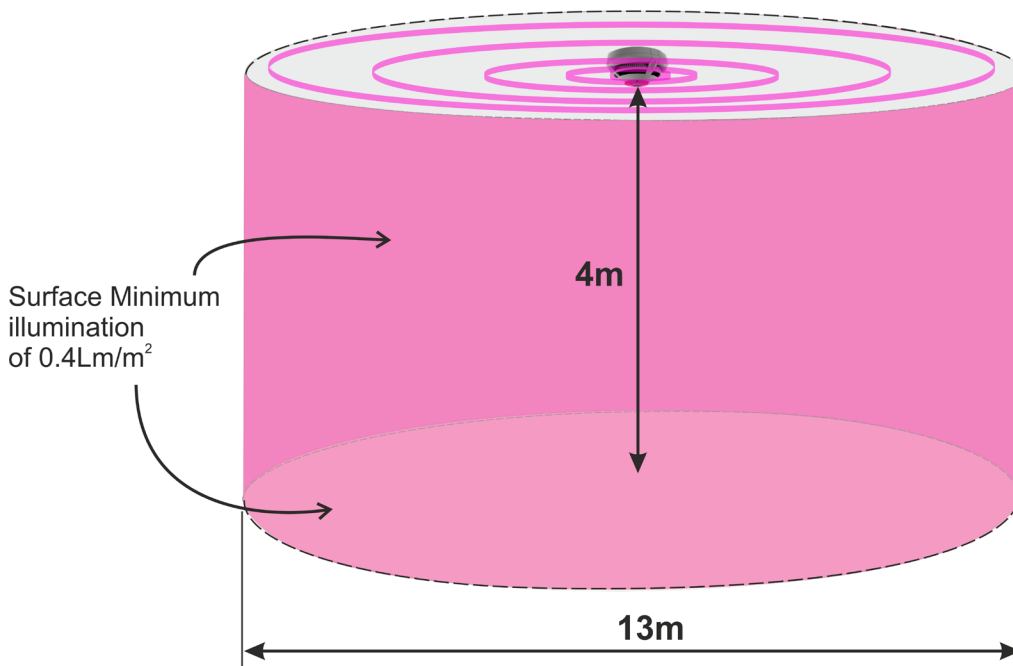

Fig. C Category 'O' Coverage height 4m by 13m diameter

Visual Alarm Coverage



It is essential that the 'Battery Standby and Loop Load calculator' is used for system design.

High performance of S-Quad Self-Test Red VAD (HPR)

Power setting	Maximum loop current and power for the VAD only	Maximum loop current and power for the sounder (minimum voltage)	Maximum total loop current and power for the VAD and sounder	EN54-23 coverage and column in cubic metres See Fig. A		Additional EN54-23 Category 'O' coverage and volume in cubic metres	
High	16mA (560mW)	Turbo = 4.5mA (158mW)	20.5mA (718mW)	C-3-14	461.8 m ³	Cylinder volume: Height - 4.5m Diameter - 14m See Fig. B	692.7 m ³
		Non-Turbo = 2mA (70mW)	18mA (630mW)				
Medium	11.5mA (403mW)	Turbo = 4.5mA (158mW)	16mA (560mW)	C-3-13	398.1 m ³	Cylinder volume: Height - 4m Diameter - 13m See Fig. C	530.9 m ³
		Non-Turbo = 2mA (70mW)	13.5mA (473mW)				
Low	6mA (210mW)	Turbo = 4.5mA (158mW)	10.5mA (368mW)	C-3-10	235.6 m ³	None	
		Non-Turbo = 2mA (70mW)	8mA (280mW)				

Note the above table show worst case performance of the Red VAD (high performance-HPR).

CoP 0001 Coverage distance multiplication factors

The table below shows how the EN54-23 coverage specification will vary with the ambient light level and if the VAD can be viewed directly or indirectly i.e. if it relies on reflections to be viewed.

As S-Quad Self-Test is a sensor and a VAD, then its placement must always be suitable for both fire detection and warning occupants of an emergency. The coverage of the VAD has been designed so that in most cases it can match the coverage of a particular sensor. It is however advisable to site the VAD so that direct viewing is possible to maximize the VAD coverage.

Ambient light level (Lux)	Ceiling mount direct viewing	Ceiling mount indirect viewing
<100	2.8	1.3
100-200	2.4	1.2
200-300	1.9	1
300-400	1.4	0.8
400-500	1.1	0.6
500-600	0.9	0.5
600-700	0.7	0.4
700-800	0.5	0.3

Example 1:

A S-Quad Self-Test VAD is used in an open area with a rating of a 4.5m height by 14m diameter. The location has an ambient light level of up to 480 Lux and it can be viewed directly. The sensor is a Optical-Heat. The maximum mounting height is:
 $4.5 \times 1.1 = 4.95\text{m}$

It will have a maximum coverage diameter of:

$14 \times 1.1 = 15.4\text{m}$ (limited by the 15m optical spacing)

However as the Optical sensor has a coverage diameter of 15m then this will limit the maximum VAD diameter to 15m.

The maximum square spacing will then be the same as a smoke:

$15 \times 1/1.414 = 10.6\text{m}$

Example 2:

A S-Quad Self-Test VAD is used in an open area with a maximum rating of a 4.5m height by 14m diameter. The location has an ambient light level of up to 390 Lux and it can only be viewed indirectly. The sensor is a Heat-only. The maximum mounting height is:

$4.5 \times 0.8 = 3.6\text{m}$

It will have a maximum coverage diameter of:

$14 \times 0.8 = 11.2\text{m}$ (limited by the 10.6m heat spacing)

In this case even if the viewing is indirect and at a high ambient light level, the maximum heat sensor can be used.

The maximum square spacing will be limited by the heat sensor:

$10.6 \times 1/1.414 = 7.5\text{m}$.

Gent VAD Tool

The above examples are simple calculations. Use the Gent VAD Tool from App Store for accurate calculations. With this tool you can create a floor plan, enter ambient light settings or use the built-in lux meter, select low, medium or high-powered settings. You can drag and drop VAD's onto your floor plan and get an instant, visual confirmation that your proposed plan is valid.

Compatibility

At the time of releasing this issue of data sheet the S-Quad Self-Test devices were compatible for installation on the loop circuits of fire alarm system based on panels having the following Main Controller Card/Board (MCC / MCB) and Loop Processor Card (LPC) software.

VIGILON

≥ means greater than or equal to.	Vigilon 4 Loop	Vigilon Compact	Vigilon 1-6 Loop	
Card ->	MCC	MCB	MCC	LPC
All S-Quad S4T range The devices with VADs operate in 'Compliant mode', i.e meets EN54 Part 23	≥ 4.64	≥ 4.64	≥ 4.64	≥ 4.58
Minimum version to enable additional Self-Test (2026) features: Purge, Anti-Mask & AV (audio visual) silent test.	≥ 4.65 26/11/24	≥ 4.65 26/11/24	≥ 4.65 26/11/24	≥ 4.59 2/12/24

Gateway: 4.6.0.5

Self Test Device Firmware: ≥ 5.1.0.2

Sounder Device Firmware : ≥ 5.0.0.1

A Vigilon System is configured using the Vigilon Commissioning Tool ≥ V1.40



Additional features such as: Anti Mask, Purge and AV background test are applicable to devices manufactured from May 2026 with a version number v5.xx or greater. Devices manufactured before May 2026 will return a fault/warning message, indicating that Anti Mask, Purge and AV background tests could not be performed on these older devices.

How to check card software version

The Master Control Board MCB and Master Control Card MCC are always Card 0. There can be up to 2 loop cards installed in a Vigilon Compact Panel in slots labelled Card 1 and Card 2 on the MCB.

There can be up to 4/6 loop cards installed in a EN54 Vigilon 4/6-loop panel. The loop cards are installed in slots labelled **Card 1 to Card 4/6** on the backplane.

- Press the **MENU ON/OFF** button.
- Press the F3 button to select **[Info]**.
- To display a Device label: Press the F1 button to select **[Display]**.
- Press the F4 button to select **<etc>** until **[Status]** appears on the display.
- Press the F2 button to select **[Status]**.
- Press the F3 button to select **[Card]**.
- Enter the Card number: For MCC/MCB this is card 0 and for the Loop processor card LPC this can be card 1,2,3, 4, 5 or 6 dependent on panel type.
- Press the F2 button to select **[Enter]**. Notice the selected card status is displayed to include the software version number.

Approved S-Quad Self-Test STATES

The STATE in which an S-Quad Self-Test sensor operate can be changed from the default factory set STATE to another STATE configured during commissioning using the Vigilon Commissioning tool. The environment in which an S-Quad Self-Test device is installed will determine what STATE is used.

Device	LPCB approved STATES	Meets ~ EN54-7 : 2018 * EN54-5 : 2017 + A1 : 2018
S4 Self-Test Dual Optical & Heat sensor variant - S4T-711 (With VAD) S4T-711-VAD-HPR (With Speech) S4T-711-V (With VAD & Speech) S4T-711-V-VAD-HPR S4TB-711-V-VAD-HPR (With Sounder) S4T-771-S	STATE 0 #	Normal sensitivity optical smoke ~ / Category A1 heat *
	STATE 2	Low sensitivity optical smoke ♦ / Category A1 heat *
	STATE 3	High sensitivity optical smoke ~ / Category A1 heat *
	STATE 4	Normal sensitivity (no spike) optical smoke ~ / Category A1 heat *
	STATE 5	Normal sensitivity optical smoke ~ / Category B heat *
	STATE 6	Low sensitivity optical smoke ♦ / Category BS heat *
	STATE 7	Normal sensitivity optical smoke ~ / Category A2S heat *
	STATE 8	Delayed normal sensitivity optical smoke ~ / Category A1 heat*
	STATE 11	Low sensitivity optical smoke ♦ Category B heat *
	STATE 12	Category A1 heat *
	S4 Self-Test Optical & Heat sensor variant - S4T-710 (With Sounder) S4T-770-S	STATE 0 #
STATE 2		Low sensitivity optical smoke ♦ Category A1 heat*
STATE 3		High sensitivity optical smoke ~ / Category A1 heat*
STATE 4		Normal sensitivity (no spike) optical smoke ~ / Category A1 heat*
STATE 5		Normal sensitivity optical smoke ~ / Category B heat*
STATE 6		Low sensitivity optical smoke ♦ Category BS heat*
STATE 7		Normal sensitivity optical smoke ~ / Category A2S heat*
STATE 8		Normal sensitivity (delayed) optical smoke ~ / Category A1 heat*
STATE 11		Low sensitivity optical smoke ♦ Category B heat*
STATE 12		Category A1 heat*
S4 Self-Test Heat sensor variant - S4T-720 (With Speech & VAD) S4T-720-V-VAD-HPR (With Sounder) S4T-780-S	STATE 0 #	Category A1 heat *
	STATE 5	Category B heat *
	STATE 6	Category BS heat *
	STATE 7	Category A2S heat *
	STATE 13	Category A2 heat *

- factory default STATE. ♦ Low sensitivity optical smoke sensing is not approved but may still be useful in certain applications.

S4 Self-Test

Dual Optical Heat & Optical Heat sensor STATES

STATE	Definition / Category	Application in / Suitable for:	Sensitivity a-high- to-k-none
STATE 3	High sensitivity optical, Category A1 heat	Area where smoke, dust or steam occurs at times.	a
STATE 4	Normal sensitivity with no optical spike protection, Category A1 heat	General area as STATE 0 with less immunity to steam and dust for ease of testing using artificial smoke in normal operating mode, when test / commissioning mode is not active.	b
STATE 0#	Normal sensitivity optical, Category A1 heat	General area.	c
STATE 8	Delayed normal sensitivity optical, Category A1 heat	General application in area with transient steam, dust or smoke present.	d
STATE 7	Normal sensitivity optical, Category A2S heat	General application in area with low dust, smoke or steam present, for fixed temperature operation that is totally unaffected by transient temperature variation.	e
STATE 5	Normal sensitivity optical, Category B heat	Area having high ambient temperature with low dust, smoke or steam present.	f
STATE 2	Low sensitivity optical smoke \diamond , Category A1 heat	Areas with moderate dust, smoke or heat during working hours when used with timing function.	g
STATE 11	Low sensitivity optical smoke \diamond , Category B heat	Area having high ambient temperature, plus where moderate dust, smoke or steam present.	h
STATE 6	Low sensitivity optical smoke \diamond , Category BS heat	Area having high ambient temperature that changes, plus moderate dust, smoke or steam present.	i
STATE 12	Category A1 heat only	Area where smoke, dust or steam occurs at times.	j
STATE 15	No detection		k

- factory default STATE. NOTE: All the Sensor STATES in the above table are LPCB approved to EN54-5 & EN54-7 with the exception of STATES 2, 6 and 11 which are only approved to EN54-5. \diamond Low sensitivity optical smoke sensing is not approved but may still be useful in certain applications. The STATE 15 is no detection and is not part of LPCB approval.

S4 Self-Test

Heat sensor STATES

STATE	Definition / Category	Application in / Suitable for:	Sensitivity a-high- to-k-none
STATE 0#	Category A1 heat	Area having high levels of smoke, dust or steam.	a
STATE 13	Category A2 heat	Area where there is moderate temperature changes plus dust, smoke or steam present.	b
STATE 7	Category A2S heat	Area where fixed temperature operation is required, but is totally unaffected by transient temperature variations.	c
STATE 5	High temperature Category B heat	Area having high ambient temperature plus dust, smoke or steam present.	d
STATE 6	High temperature Category BS heat - with no rate of rise component	Area where there is rapid temperature changes plus dust, smoke or steam present.	e
STATE 15	No detection		f

- factory default STATE. NOTE: All the Sensor STATES in the above table are LPCB approved to EN54-5. The STATE 15 is no detection and is not part of LPCB approval.

Device Status

To view the status of an S-Quad Self-Test device following the allocation of the loop circuit on which it is installed

- a. Press Menu On/Off button.
- b. Select [Info], momentarily press <etc> to select [Status]
- c. Select [Device] and enter a device number
- d. Select [Loop] and enter the loop number and then [Enter] to view device status information.

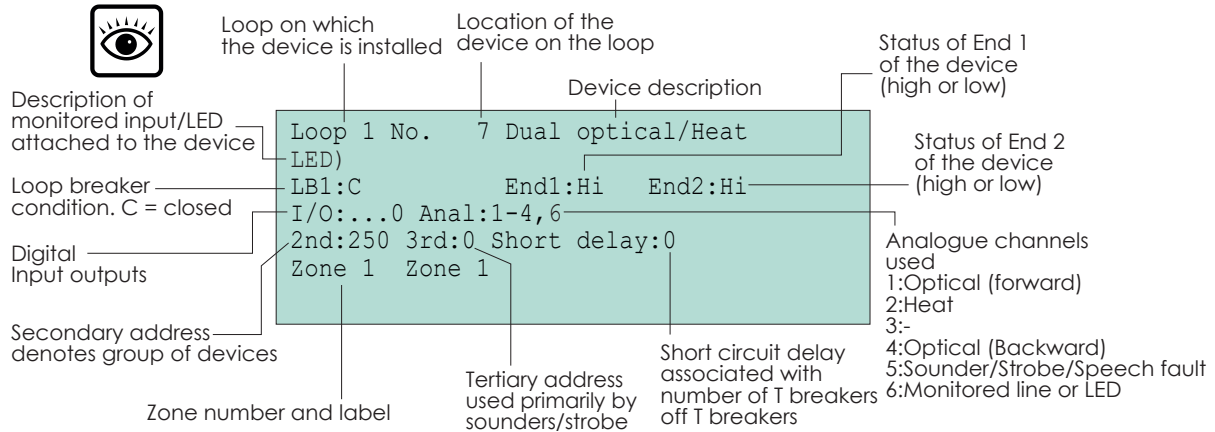

Part No.	Product	Digital I/O				Analogue Channels
S4T-720	S4 Self-Test Heat Sensor	.	.	.	0	2
S4T-710	S4 Self-Test Optical Heat Sensor	.	.	.	0	1, 2
S4T-711	S4 Self-Test Dual Optical Heat Sensor	.	.	.	0	1, 2, 4
S4T-780-S	S4 Self-Test Heat Sensor Sounder	.	0	0	0	2, 5
S4T-770-S	S4 Self-Test Optical Heat Sensor & Sounder	.	0	0	0	1, 2, 5
S4T-771-S	S4 Self-Test Dual Optical Heat Sensor & Sounder	.	0	0	0	1, 2, 4, 5
S4T-711-V	S4 Self-Test Dual Optical Heat Sensor & Voice Sounder	.	0	0	0	1, 2, 4, 5
S4T-711-VAD-HPR	S4 Self-Test Dual Optical Heat Sensor & High Power Red VAD	0	.	.	0	1, 2, 4, 5
S4T-720-V-VAD-HPR	S4 Self-Test Heat Sensor, Voice Sounder & High Power Red VAD	0	0	0	0	2, 5
S4T-711-V-VAD-HPR	S4 Self-Test Dual Optical Heat Sensor, Voice Sounder & High Power Red VAD	0	0	0	0	1, 2, 4, 5
S4TB-711-V-VAD-HPR	S4 Self-Test Black Dual Optical Heat Sensor, Voice Sounder & High Power Red VAD	0	0	0	0	1, 2, 4, 5
	+ Monitored input / + Monitored output					6
		- = Unconnected 0 = Output				

Analogue Channel 1 is forward scatter optical smoke sensor

Analogue Channel 2 is heat sensor

Analogue Channel 3 -

Analogue Channel 4 is for backward scatter optical smoke sensor

Analogue Channel 5 reports sounder / VAD / speech faults to the control panel

Analogue Channel 6 reports monitored input/monitored output faults/operation to the control panel.

The correct device type may not be displayed if the loop circuit has allocation faults.

Exceptions or Condition codes

The Exception codes are also sometimes called condition codes and these codes provide information about a sensor device. A code indicates small changes in the:

- environmental condition
- sensor mechanism and
- how the sensor performs in the system.



To ensure that the sensor exception codes are meaningful, after power up the system should be left undisturbed for at least 24 hours.

Definition

There are ten different conditions possible for each sensor type, although not all of them are defined. Each condition code has a range of 0-3,

Exception/Condition Code	Meaning
0	This condition is OK. This code is not displayed unless another non zero code exists.
1 or 2	Suggest preventive maintenance is required, where necessary, to avoid possible false alarms.
3	The sensor is faulty. A fault condition indication is given at the control panel. A message reading 'Sensor Out of Specification' is displayed.



A sensor having code 3 is automatically disabled by the system to prevent false alarms.

To view the exceptions/condition codes of a device/outstation:

- a. Press Menu On/Off button
- b. Select [Info] and press <etc> to select [Event]
- c. Press <etc> and select [Exception] and then select [Enter].

Time and date when Exceptions or Condition codes were read.

How to interpret Exception Codes

Exceptions /Condition codes	Meaning	Action
1000000000 or 0100000000 or 1100000000	This is the sub-fire band and if set should be taken as showing that the sensor is at its optimum sensitivity for its location.	No action need be taken.
2000000000 or 0200000000 or 2200000000	A sub-fire has been generated which would suggest that the sensor was either too sensitive for its environment or that the sensor type may be incorrect for the location.	Action should be to check location and alter sensor state or type as required. The customer should be made fully aware of this change. Remember to backup all changes of states onto the NVM.
0010000000 or 0020000000	These codes indicate that the sensor is in a windy location. This will cause the chamber voltage to drop. Code Level 1 shows one drop only, Level 2 shows greater than one drop.	The location should be checked and a change in siting made, if required. Note: Wind will not cause the sensor to false alarm.
0000100000 or 0000200000 or 0000010000 or 0000020000	This shows that the sensor time averages are close to acceptable limits.	On commissioning the sensor should be replaced. A sensor with code 2 is worse than code 1. On maintenance sensors with code 2 should be replaced.

Exceptions /Condition codes	Meaning	Action
0000001000 or 0000002000 or 0000000100 or 0000000200	This shows sensor hardware faults. 1 for code 1 and more than one for a code 2.	The sensor should be replaced.
0000000010 or 0000000020	This shows sensor hardware faults. 1 for code 1 and more than one for a code 2.	The sensor should be replaced.
0000000001 or 0000000002	This shows that transmission faults are being noted. Code 2 is worse than code 1.	The sensor should be replaced. If it reoccurs then check the environment.

How to clear Exception codes

This can be done by removal and replacement of the sensor chamber, by re-allocation of the loop having the sensor or by using the menu controls.

- a. Press Menu On/Off button.
- b. Select [Test/Eng] and then [Usercode].
- c. Select <etc> to display and select [Config].
- d. Select [Clear] and then select [Exception] and [Enter].



All cleared codes will return if the conditions are still true.

Condition Codes for devices (Exception / Sub Fault codes)

Gen type	Pos. No.	Description	Exception codes			
			Normal band 0	Sub fault band		Fault band 3
				1	2	
ENVIRONMENT	1	Optical subfire	None	Small signal sensed [Check location, STATE & type]	Subfire [Check location, STATE & type]	
	2	Heat subfire	None	Small signal sensed [Check location, STATE & type]	Subfire [Check location, STATE & type]	
	3					
	4					
SENSOR	5	Optical channel drift or out of range	OK		Close to acceptable limit	Out of limits [Clean/replace]
	6	Heat channel drift or out of range	OK			Out of limits [Clean/replace]
	7	Optical channel noisy (High freq)	OK	Single HF noise event detected	Multiple HF noise seen (Check location and report)	
	8	Heat channel noisy (High frequency)	OK	Single HF noise event detected	Multiple HF noise seen (check location and report)	
DEVICE	9	device firmware	OK	Isolated fault [Note/report]	Repetitive fault [Note / report / replace]	Total failure [Replace]
	10	device transmission	OK	Low error rate	Medium error rate [Report]	High error rate [Replace]

Time average readings

The typical time average values for sensors under normal operating condition are shown in the table below.

Part No.	Product	Analogue Channels	Time average at manufacture Tnew
S4T-720	S4 Self-Test Heat Sensor		
S4T-710	S4 Self-Test Optical Heat Sensor		
S4T-711	S4 Self-Test Dual Optical Heat Sensor		
S4T-780-S	S4 Heat Sensor Sounder	2 - Heat	66
S4T-770-S	S4 OH Sensor Sounder	1 - Optical (forward) 2 - Heat	25 66
S4T-771-S	S4 Dual OH Sensor Sounder	1 - Optical (forward) 2 - Heat 4 - Optical (backward)	25 66 40
S4T-711-V	S4 Dual OH/Voice Sounder	1 - Optical (forward) 2 - Heat 4 - Optical (backward)	25 66 40
S4T-711-VAD-HPR	S4 Dual OH/Red VAD (HP)	1 - Optical (forward) 2 - Heat 4 - Optical (backward)	25 66 40
S4T-720-V-VAD-HPR	S4 Heat / Voice Sndr. / Red VAD (HP)	2 - Heat	66
S4T-711-V-VAD-HPR S4TB-711-V-VAD-HPR	S4 Dual OH / Voice Sndr. / Red VAD (HP) S4 Dual OH / Voice Sndr. / Red VAD (HP)	1 - Optical (forward) 2 - Heat 4 - Optical (backward)	25 66 40
	Beam Transmit		0
	Beam Receive	2	150 - 170

Checking the time averages

Press the Menu On/Off button and then [Info], momentarily press <etc> to select [Time Avg] and type in the required channel number from the range 1-6 whose time average is required, select [Device] and type in the device number, select [Loop] and type in the loop number of the device ->[Enter]. The display shows time averages for the device. If necessary select [Repeat] to refresh the readings.



Time average readings of Channel 1 device 1 loop 1

Tnew (On demand)
 Foreground (fast) Time average readings T1 to T5 of Channel 1 Device 1 loop 1
 Background (slow) Time average readings T6 of T11 Channel 1 Device 1 loop 1

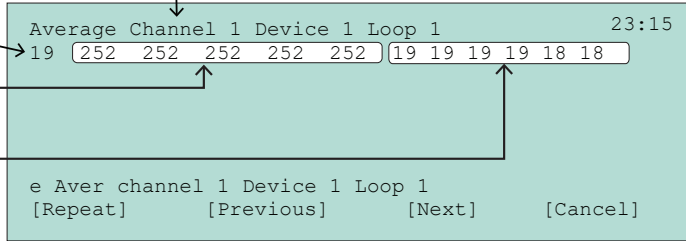

	Foreground (fast) time average readings					Background (slow) time average readings					
Tnew	T1	T2	T3	T4	T5	T6	T7	T8	T9	T10	T11
On demand	80mS	320mS	1.28S	5.12S	20.48S	1.36min	5.46min	21.84min	1.45hr	5.82hr	23.3hr

Normally reads 252, unless there is a threshold.

Message Action List

This list shows the messages that are likely to be displayed at the control panel or at a loop repeat panel in the fire system.

Message Action list

The messages displayed at the control panel or loop repeat panels are given for guidance only:

- ▣ fault message
- ▣ likely meaning of the message
- ▣ along with suggestions on what initial actions may be taken to rectify the problem.
- ▣ the term Outstation and Device are used interchangeably



Only the messages that are applicable will appear on the display of the control panel or loop repeat panels.

Message	associated with..	meaning..	..possible action
Flash memory checksum error	Device	Speech Memory Checksum Error	Replace the device
Invalid Configuration	Device	EEPROM incorrectly programmed	Replace the device
Invalid configuration	Loop	Loop recovered with freeblocks ON	This is not allowed. Switch OFF the freeblocks and reallocate.
Memory corrupt	Device	EEPROM checksum failure	Replace the device
Program memory corrupted	Device	Checksum failure on EPROM at midnight	Clear and ignore single occurrence. Record in log book.
Sounder circuit has failed	Device	There is a fault with the sounder hardware on the S-Quad Self-Test or S-Cubed.	Replace the device
Sounder circuit Restored	Device	The fault on the sounder S-Quad Self-Test or S-Cubed has been restored.	-
Speech circuit has failed	Device	There is a hardware fault possibly associated with the voice chip on the speech S-Quad Self-Test or S-Cubed.	Replace the device
Speech circuit Restored	Device	The fault on the speech S-Quad Self-Test and S-Cubed has been restored.	-
Strobe (VAD) circuit has failed	Device	The strobe (VAD) circuit on the S-Quad Self-Test or S-Cubed device has failed	Replace the device
Strobe (VAD) circuit Restored	Device	The hardware fault associated with the strobe (VAD) has been restored.	-

Finding a device

The 'find device' is a function that gives a visual or audible indication at the respective S-Quad Self-Test device on a loop circuit.

- Press the **Menu On/Off** button and then [**Test/Eng**].
- Select [**Loop**] and then [**Find Dev**].
- Now enter a Loop card number to select the loop circuit.
- Select [**Start**] and type in a device number (usually device 1 is entered).
- Select [**Enter**]. The display shows the device and loop number.

Number 1 on Loop 1

- Press [**Next**] to find the next device on the loop and at any stage if the previous device needs to be found then select [**Previous**].

A found device will provide visual or audible indication:

- On any S-Quad Self-Test device there will be a flashing indication given by the local LED.
- An S-Quad Self-Test with Sounder, but without speech, will cause the Sounder to output pulsed tone
- An S-Quad Self-Test with Visual Alarm will cause the light to operate.
- An S-Quad Self-Test with Speech will cause a tone followed by announcement of a test message: "This is a test message no action is required".

Turbo and Non Turbo Modes

The S-Quad Self-Test devices can output in turbo and/or in non turbo modes. When the panel commands a low or high tone output at device, if configured during commissioning, the device will output turbo and/or non turbo tones. The **high and low FAB mappings** are used to change the tone output of the sounder. The turbo mode outputs a waveform with a basic frequency that is the same frequency as the resonant frequency of the piezo. The non turbo mode outputs modulated turbo waveform.

No.	Description		
0	Turbo square wave		
1	Turbo high tone		
2	Turbo low tone - high output		
3	Turbo low tone		
4	Turbo rich high tone		
5	Turbo rich low tone		
8	Non-Turbo square wave		
9	Non-Turbo high tone		
10	Non-Turbo low tone - high output		
11	Non-Turbo low tone		
12	Non-Turbo rich high tone		
13	Non-Turbo rich low tone		



The volume levels and power requirements of the device operating in turbo mode are significantly higher than in non-turbo mode.

System test

See Self-Test section in Part 1 of this manual

Other Tests on S-Quad Self-Test devices

- The sensor(s) part of the S-Quad Self-Test device must be system tested to check the configured cause and effect in the event of fire(s).
- where the Sound and Speech are part of the device ensure each device outputs the correct signal at the appropriate volume level and ensure the VAD operate at the required flash rate.
- Each S-Quad Self-Test device should be tested for correct operation in the event of real fire.
- The sound levels in the areas should be tested in accordance with the British Standard requirements and to meet the site specific needs as agreed with the customer.

Other installed equipment off interface unit



1. **DO NOT** use a heat gun when testing conventional heat detectors off interface unit installed in hazardous environment.
2. Use recommended test equipment and methods to fire test flame detectors off interface units, see instructions supplied with Flame Detector.
4. When smoke testing a fire detector using artificial smoke, avoid excessive spray to prevent accumulation of sticky residue on detector, see instructions on the smoke canister.
5. A beam sensor should be tested using obscuration filters to simulate smoke at default sensitivity.

Vigilon Commissioning tool settings for S-Quad Self-Test range

See Vigilon Commissioning tool user guide for full information.

1a Menu selection: Configuration

1b Menu selection: SQuad Config...

1 Icon selection: S4

Sounder or Speech and VAD enable / disable

High and Low tone selection or Tone followed by message selection for signals 0, 1, 2 and 3

VAD flash rate setting of 4 = 0.25Hz, 2 = 0.5Hz and 1 = 1Hz.

2 Signal configuration table:

Signal	Low/ Attn Tone	High/ Message	Audible On	VAD/Str Actioned	Speech Operation	VAD/Str Period#	PreSpeech Silence	PostSpeech Silence
Signal 0	00	04	<input checked="" type="checkbox"/>	<input checked="" type="checkbox"/>	<input checked="" type="checkbox"/>	4	0	0
Signal 1	00	03	<input checked="" type="checkbox"/>	<input checked="" type="checkbox"/>	<input checked="" type="checkbox"/>	2	0	0
Signal 2	00	05	<input checked="" type="checkbox"/>	<input checked="" type="checkbox"/>	<input checked="" type="checkbox"/>	2	0	0
Signal 3	00	02	<input checked="" type="checkbox"/>	<input checked="" type="checkbox"/>	<input checked="" type="checkbox"/>	2	0	0

3 Device settings: Line Type (UnMonitored Output)

To select line type:
 - Unmonitored output
 - Monitored input or
 - Monitored output

To select input type:
 - Fire detector
 - Fault
 - Supervisory
 - Other fire
 - MCP fire

4 All Devices: Background Monitoring, Compatibility mode for speech sounders**

High and Medium power settings are only available for Enhanced Loop Card.

5 Soft start settings: Start Volume, Increment

Select the maximum required volume out of Sounder and Speech S-Quads.

All % settings range from 0 to 100% in increments of 5%

10 to 60 seconds

High and Low FAB mapping with a selection from a range of turbo and non turbo tones, including rich, square wave and high output tones.

* To comply with EN54 Pt 3, the min volume of a sounder should be at least 65dBA, which equates to 16% of max volume for S-Quad devices

** Note. Compatibility mode for speech sounders will set volume to 100%.

For compliance to EN54-23 the flash rate of VADs should be set to '2'. Flash period > 2 seconds are only supported on Enhanced Loop Cards.

VAD settings

VAD Power: Med.C-3-13 O-4-13

These settings should be used with the LPCB CoP 0001 to determine coverage

VAD Power:
 - High C-3-14 O-4.5-14
 - Med.C-3-13 O-4-13
 - Low C-3-10 None

Selected VAD device can have *high, medium and low* power setting. This setting is selectable using this drop down menu. Refer to the product data sheet for further information on VAD power settings.

Category 'O'	
Old reference	New reference
O-4.5-14	Cylinder volume: Height - 4.5m, Diameter - 14m
O-4-13	Cylinder volume: Height - 4m, Diameter - 13m

- ⚠ **Background monitoring is not applicable for Self Test devices.** Background monitoring of non-self test devices, such as S-Cubed Mark 3 or an S-Quad Mark 2/3.
 No tick - Off,
 Grey tick - every 6 hours (for New device like a Pt 23 device) / every 1 hour (for Old devices) and
 Black tick - every 24 hours
- S4T Devices with Self-Test functionality.

Note the Commissioning tool will not distinguish between part number prefix S4TB and S4 of equivalent devices.

