

S³ Mark II - Data and Installation Addressable Speech Sounder and Strobe Devices

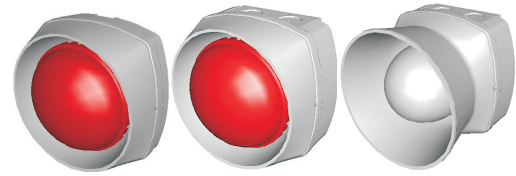

These instructions cover the following range of addressable S³ devices, which are suitable for installation in GENT analogue addressable fire alarm system:

Low profile range				
Speech Sounder		Speech Sounder Strobe (red lens)		
	Deep base	Shallow base	Deep base	Shallow base
White	S3IP-VP-W	S3-VP-W	S3IP-VP-ST-WR	S3-VP-ST-WR
Red	S3IP-VP-R	S3-VP-R	S3IP-VP-ST-RR	S3-VP-ST-RR

System range	
	Speech Sounder
	Deep base
White	S2IP-VP-W
Red	S2IP-VP-R



All of these parts are LPCB approved #

These products are not visual alarm devices and does not meet EN 54-23.

The Strobe and Speech functions are not LPCB approved.

Note: The system range of products do not support strobe options.

The low power addressable Voice Enhanced Sounder and combined Strobe products provide audible and visual alarm signals, and are designed for use in GENT analogue and addressable fire alarm systems.

The S³ devices are supplied with standard speech messages along with sounder and strobe option. The devices are configured during commissioning to operate to site specific requirement. The devices are supplied with either a deep base (40mm) or a shallow base (25mm), offering IP55C and IP31C ratings respectively. The system range is available with deep base only.

In addition to the products covered in this leaflet there are Sounder, Sounder/Strobe and Strobe only variants, for information contact your supplier.

The S³ product range incorporates innovative design features protected by Patents GB2388994, GB2388995 and GB2388916. The product design has also been registered.

Do's and Don'ts

- Do's**
- Check to ensure the S³ Mark II products are compatible with the system control panel software, see compatibility section.
 - Use correct method to open and close the device

- Mount the device in correct orientation with 'TOP' uppermost, to allow remote control operation
 - Fit the **wall gasket** first when installing the deep base if IP55C protection is required
 - Ensure the **transparent cover** is in place over the PCB
 - Ensure the **earth continuity strap** is in place in the **deep base**
- Don'ts**
- Don't flush mount the Base.
 - Don't have excessive incoming cable slack
 - Don't locate unit such that the audible and visual outputs are obstructed
 - Don't mount the device above obstructions, such as shelves, that can prevent its operation with the IR remote control
 - Don't paint the device enclosure.

Bases

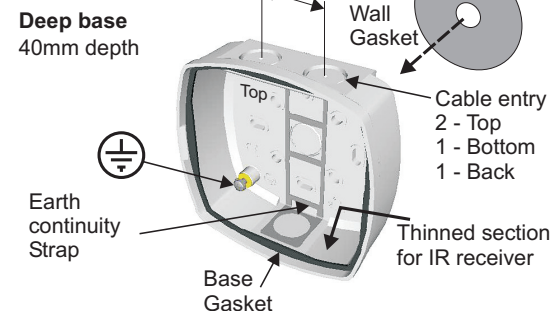
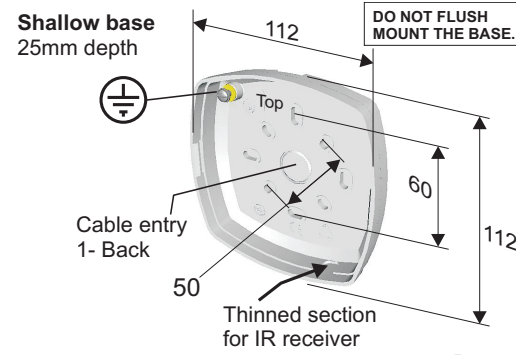

How to open and close the assembly

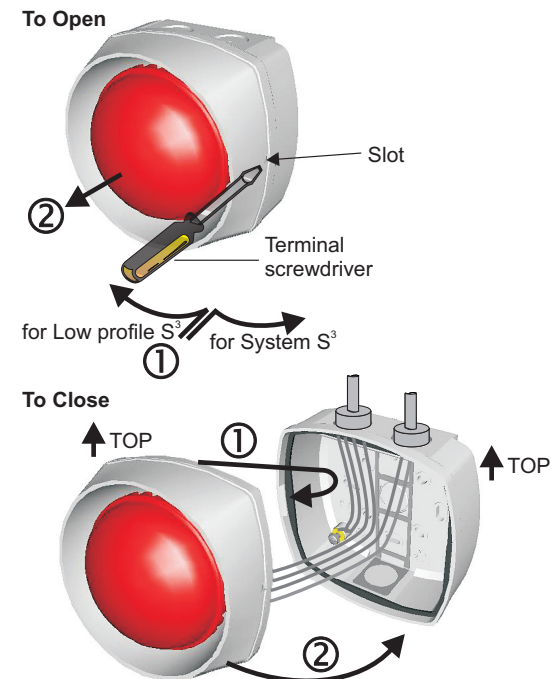

Installation

- Drill or knockout the required cable entry points on the **Base**.
- If using the deep base option and IP55C protection is required, then stick on the circular **wall gasket** on to the centre back of the **base**.
- Secure the Base to the wall whilst ensuring Top of the base is in correct orientation.
- Terminate the cable at the entry point leaving no more than 10cm (4") tail wire length for connection.

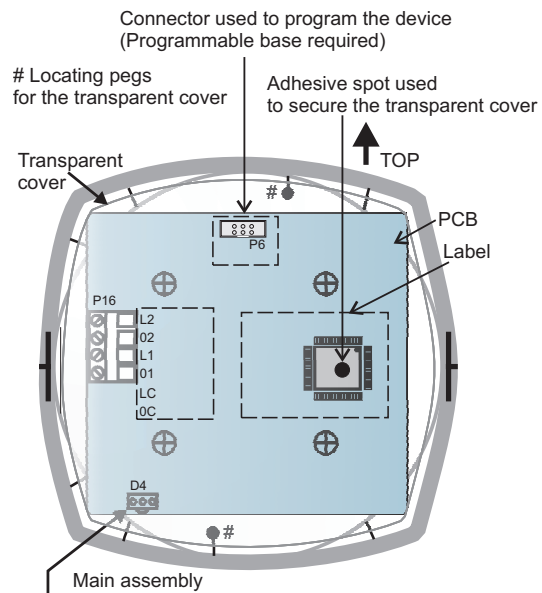

- Ensure the **transparent cover** is in place over the **PCB**. Connect the wires to the terminal block, see Wiring.
- Close the **main assembly** to the base.

Wiring

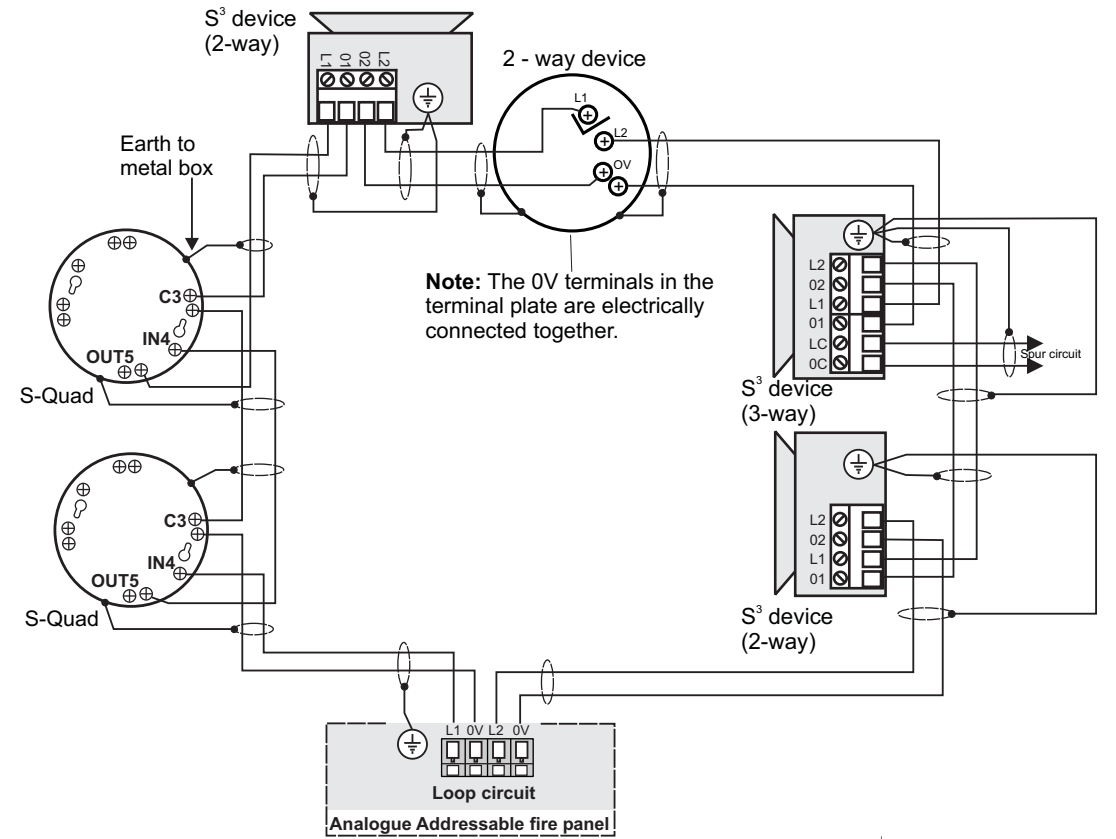

Technical data

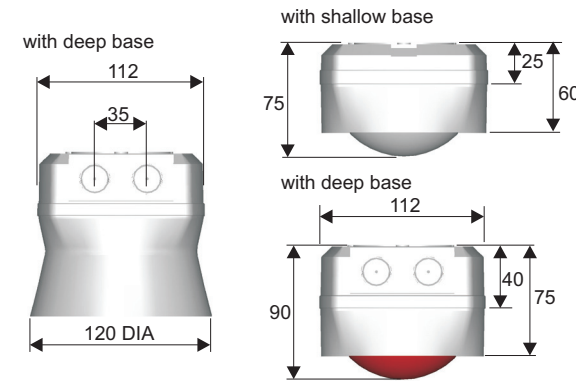

Note: If you have a speech/sounder only product then ignore the strobe information given.

Sound output for standard tone (levels given are typical values with measurement taken at 90° anechoic - fast response) #	Low profile S ³ - 100dBA +/-3dBA
	System S ³ - 103dBA +/-3dBA
Standard	EN54:Part 3:2001 (for sounder only) + EN54:17:2005
Messages, Tones and Strobe flash rate	see information on the next page
Strobe light output with red lens	equivalent to 3W Xenon flasher
Operating voltage	range 35V - 41V
Terminal size	2.5mm ² maximum
IP rating	
	with deep base IP55C
	with shallow base IP31C
Enclosure colour	White and Red (with red translucent lens cover for the Strobe)

Loop loading factors	per device
Standard tone - with Speech	5 - 17
Standard tone with red Strobe plus Speech	13
Complex tone 'Tone n' with red Strobe	25
Enclosure material	Flame retardant ABS (Strobe cover is polycarbonate) The plastic enclosures meet the flammability requirements of ISO 1210:1992 Class FH-2.
Weight	0.3Kg (approximate)
Operating temperature	-10°C to +50°C
Storage temperature	-20°C to +70°C
Relative humidity (non condensing)	up to 90%
IR operating distance (used for selecting volume level)	3m
Message and attention Tone period	10 seconds default Configurable up to 60seconds
EN54-17 data	V _{max} 42V I _{Cmax} 0.4A V _{nom} 40V I _{Smax} 1A V _{min} 24V I _{Lmax} 4μA V _{SOmax} 10.6V Z _{Cmax} 112mΩ V _{SO min} 9.8V

The addressable S³ products are fully synchronised on the same fire panel.

Minimum volume setting a Sound Pressure Level (SPL) of above 65dB(A) is achieved in at least one direction in all operational modes.

Information on minimum sound output levels to include polar dispersion is covered in technical note TECH6310.029, available on request from manufacturer.

Addressable Speech Sounder and Strobe

Note: Only the messages and complex tones specified in the following table are applicable to this S³ product.

Message 1	Bell tone
Message 2	Attention please this is an emergency please leave the building by the nearest available exit. (female voice)
Message 3	An incident has been reported in this building please await further instructions. (female voice)
Message 4	This is a test message no action is required. (female voice)
Message 5	This is a fire alarm please leave the building immediately by the nearest available exit. (male voice)

There are four default messages in English plus a bell tone. However your system may carry special messages.

Signals

Signal	Description
Signal 1*	Intermittent tone 970Hz @ 1Hz
Signal 2*	Alternating tone 800/970Hz @ 2Hz
Signal 3*	High Tone (Continuous 970Hz)

The Signals marked with an * are LPCB approved.

Speech function

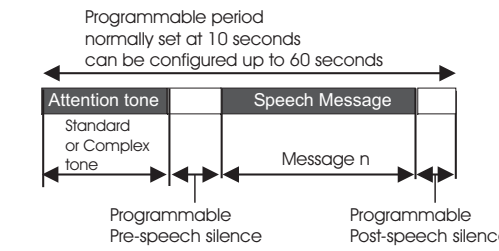

It is possible to reprogram factory set speech messages, for which a programmable base is required - contact Gent for information.

The S³ Speech sounder function is provided by stored messages on a flash memory chip within the assembly. The standard flash memory can hold up to 20 seconds of audio and additionally it holds local complex attention tones, such as the bell and DIN signals. Each signal output from an S³ Speech device consists of an attention tone followed by a message. The attention tone can be a local complex tone or a panel tone, such as the standard 'nee naw' sound.

Sounder function

A S³ sounder can operate in turbo mode if configured during commissioning to provide further 3dB output. The sound outputs are based on the settings of the FABs and SABs at the panel that gives changing levels over 2 seconds duration in 8 time slots. The standard outputs are synchronised with the 34000 sounders and other S³ devices installed in the same system. The volume of the sound output can be individually set at the device, note that the sound level should not be set lower than 65dBA at 1m for standards compliance. The system prevents adjustment of volume down to zero. Another feature that can be configured is the soft start that ramps the sound volume gradually to the maximum level set at the device.

Turbo and Non Turbo Modes

The S³ sounders can output in turbo and/or in non turbo modes. When the panel commands a low or high tone output at S³, if configured during commissioning, the S³ sounder will output turbo and/or non turbo tones. The high and low FAB mappings are used to change the tone output of the S³ sounder. The turbo mode outputs a waveform with a basic frequency that is the same frequency as the resonant frequency of the S³ piezo. The non turbo mode outputs modulated turbo waveform.

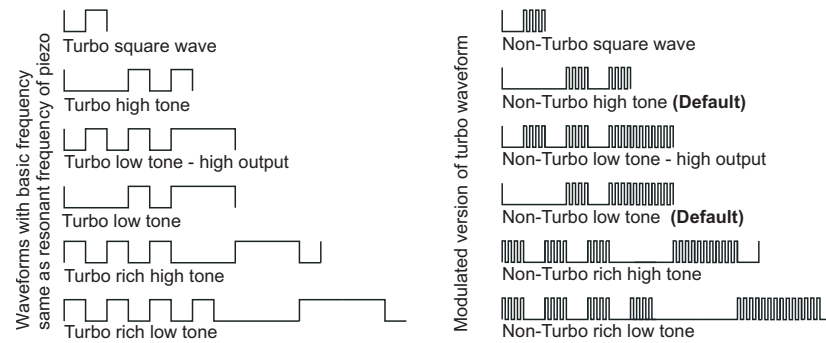

The volume levels and power requirements of the S³ operating in turbo mode are significantly higher in than non-turbo mode.

Strobe function

In the event of a fire the appropriate S³ device in the system will output alarm signals according to the site specific configuration and these can be either signal 1, 2 or 3 alarm:

- every 2 seconds with signal 1,
- every 1 second with signal 2
- every 1 second with signal 3

However the operation of the strobe with the signals 1, 2 and 3 can be changed at the commissioning stage. The strobe is synchronised with S³ and S⁴ strobes installed in the same system.



The Disability Act 1995 recommends visual alarms, like S³ and S⁴, are installed in protected premises to warn occupants who are hard of hearing.

Compatibility

At the time of releasing this data sheet the S-Cubed Mark II devices were compatible for installation on the loop circuits of the fire alarm system based on:

≥ mean - Greater than or equal to.	EN panels				
	Vigilon 4 Loop	Vigilon Compact	Vigilon Compact VA	Vigilon 4-6 Loop	All panels
Card ->	MCC	MCB	MCB	MCC	LPC
	≥4.30	≥4.30	≥4.30	≥4.37	≥4.30

≥ mean - Greater than or equal to.	BS panel	
	Vigilon	
Card ->	MCC	LPC
	≥3.90	≥3.90

Testing the S³ devices

- Test the Sounder and Speech part of the S³ and ensure each device outputs the correct signal at the appropriate volume level. Ensure the strobe operates at the required flash rate. All S³ devices in the system should have been configured using the commissioning tool.
- Each S³ should be tested for correct operation in the event of fire.
- The sound levels in the areas should be tested in accordance with the British Standard requirements and to meet the site specific needs as agreed with the customer.



2811

Gent by Honeywell (Novar Systems Limited)
Manufactured by: Honeywell Life Safety Systems,
140 Waterside Road, Hamilton Industrial Park,
Leicester, LE5 1TN, United Kingdom

13

DoP	Product No.	DoP	Product No.
033-CPR-2013	S3-SN-R-V2	039-CPR-2013	S2IP-VP-R
033-CPR-2013	S3-SN-W-V2	040-CPR-2013	S3-VP-R
035-CPR-2013	S3IP-SN-R-V2	040-CPR-2013	S3-VP-W
035-CPR-2013	S3IP-SN-W-V2	041-CPR-2013	S3-VP-ST-WR
036-CPR-2013	S2IP-SN-R-V2	041-CPR-2013	S3-VP-ST-RR
036-CPR-2013	S2IP-SN-W-V2	042-CPR-2013	S3IP-VP-R
037-CPR-2013	S3-SN-ST-RR-V2	042-CPR-2013	S3IP-VP-W
037-CPR-2013	S3-SN-ST-WR-V2	043-CPR-2013	S3IP-VP-ST-WR
038-CPR-2013	S3IP-SN-ST-RR-V2	043-CPR-2013	S3IP-VP-ST-RR
038-CPR-2013	S3IP-SN-ST-WR-V2		
038-CPR-2013	S3IP-SN-ST-RW-V2		

EN54-3: 2001 + A1: 2002 + A2: 2005, EN54-17: 2005

S3-SN-R-V2	(EN54-3 & 17)	S2IP-VP-R	(EN54-3 & 17)
S3-SN-W-V2	(EN54-3 & 17)	S3-VP-R	(EN54-3 & 17)
S3IP-SN-R-V2	(EN54-3 & 17)	S3-VP-W	(EN54-3 & 17)
S3IP-SN-W-V2	(EN54-3 & 17)	S3-VP-ST-WR	(EN54-3 & 17)
S2IP-SN-R-V2	(EN54-3 & 17)	S3-VP-ST-RR	(EN54-3 & 17)
S2IP-SN-W-V2	(EN54-3 & 17)	S3IP-VP-R	(EN54-3 & 17)
S3-SN-ST-RR-V2	(EN54-3 & 17)	S3IP-VP-W	(EN54-3 & 17)
S3-SN-ST-WR-V2	(EN54-3 & 17)	S3IP-VP-ST-WR	(EN54-3 & 17)
S3IP-SN-ST-RR-V2	(EN54-3 & 17)	S3IP-VP-ST-RR	(EN54-3 & 17)
S3IP-SN-ST-WR-V2	(EN54-3 & 17)		
S3IP-SN-ST-RW-V2	(EN54-3 & 17)		

Intended for use in fire detection and fire alarm systems in and around buildings

Refer to 033-CPR-2013, 035-CPR-2013, 036-CPR-2013, 037-CPR-2013, 038-CPR-2013, 039-CPR-2013, 040-CPR-2013, 041-CPR-2013, 042-CPR-2013, 043-CPR-2013 for level or class of performance declared, for details see website www.gent.co.uk



WEEE Directive:
 At the end of their useful life, the packaging, product and batteries should be disposed of via a suitable recycling centre. Do not dispose of with your normal household waste. Do not burn.



At the end of their useful life, the packaging, product and batteries should be disposed of via a suitable recycling centre and in accordance with national or local legislation.

Gent by Honeywell reserves the right to revise this publication from time to time and make changes to the content hereof without obligation to notify any person of such revisions or changes.

Hamilton Industrial Park, Waterside Road, Leicester LE5 1TN, UK
 Website: www.gent.co.uk
 Telephone +44 (0) 203 409 1779 Fax (UK): +44 (0)116 246 2300