

Red enclosure for Fire applications (backbox optional)

Blue enclosure for Plant interface applications (supplied with backbox)

The keyswitch units covered in this leaflet are suitable for installation in GENT analogue addressable fire alarm system. The product range covered here include:

- S4-34807 Keyswitch MCP (Red)
- S4-34418 Keyswitch Interface (Blue)
- S4-34499 Spare Keys (Pack of 2)
- S4-34895 Surface Back Box for Interface Red Plastic (Pack of 10)

Keyswitch assembly

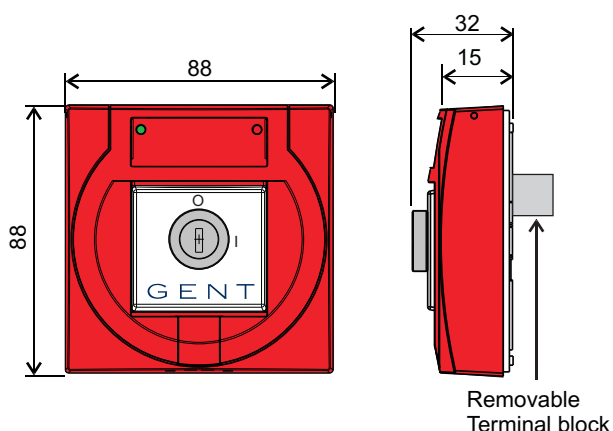

Back box

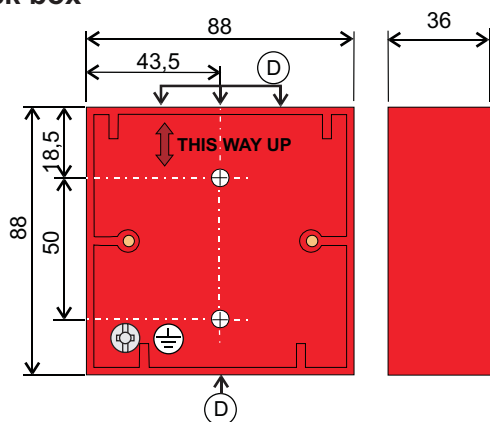

The back box has recessed centres 'D', 3 at the top and 1- at the bottom, a maximum of 2 are usable.

Symbols on product

- Switch is in the OFF position.
- Switch is in the ON position.
- Protective Earth connection terminal.
- The WEEE symbol. It indicates the product is to be recycled and not thrown away.
- The CE compliance logo. This product is in conformity with the relevant European Union harmonisation legislation.
- The RoHS compliance logo. The RoHS directive restricts the use of certain hazardous substances commonly used in electronic and electronic equipment.
- The UKCA (UK Conformity Assessed) marking is a new UK product marking that is used for goods being placed on the market in Great Britain (England, Wales and Scotland).







Technical data

Standard	EN54: Part 17 EN54: Part 18	
Dimensions	height 88 mm x width 88 mm depth 32 mm or 66 mm when surface mounted	
Full assembly weight	128g - without backbox 192g - with backbox	
Storage temperature	-30°C to +70°C	
Operating temperature	-25°C to +70°C	
Relative Humidity (Non condensing)	up to 95% (Temperature +25°C to +55°C)	
Emission	BS EN 61000-6-3:2007 + A1: 2011	
Immunity	BS EN 50130-4 : 2011	
Ingress Protection	IP43 estimated standard type	
Colour	Red (similar to RAL3020) Blue (similar to RAL5015)	
Case	ABS engineering plastic	
Indicators	Normal	Green LED for status and find device application
	Active	Red LED for active or Fire indication
Terminals	2.5mm ² maximum	
LPCB Approved	-	
Operating voltage	35V to 48V	
EN54-17 data	V _{max} 48V	/C max 0.8A
	V _{nom} 40V	/S max 1.25A
	V _{min} 35V	/L max 20 A
	V _{SO} max 16V	ZC max 0.13
	V _{SO} min 8V	

If the keyswitch MCP is used in a 3400 system then ensure the LCC and LPC software are at Version 3.30 or higher.

Installation

a) Check the contents of the package:

	Component	Quantity
	Keyswitch Interface assembly (red / blue)	1
	Earth Strap	1
	Operating Key	2
	Opening Key	1
	Long Screw	2
	Instruction leaflet	1
	Blue Back box supplied with Blue keyswitch interface assembly	1

- b) The keyswitch assembly may be mounted on a standard electrical box or on the backbox.
- c) Feed the fire rated cables through the entry holes and mount an electrical box or the red/blue back box to an even wall surface using suitable fixing.

 **When semi flush fixing the keyswitch assembly a standard electrical box must first be flushed into the wall before the keyswitch assembly is fitted.**

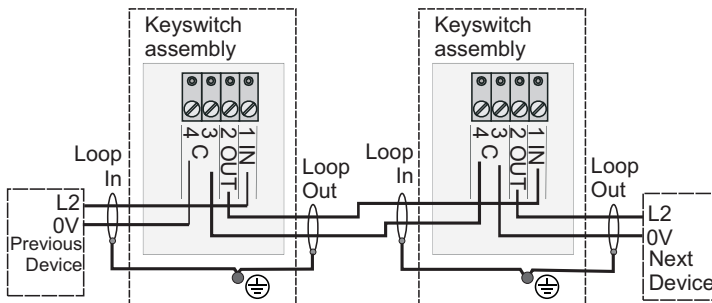

- d) Terminate each cable entry at the back box. Use the *earth strap* or the *earth point* in the back box to maintain loop cable earth continuity. Connect the loop cable to the terminals.
- e) Disengage front cover from the keyswitch assembly using the end of the opening key 'E' and lift out the cover from the bottom edge.
- f) Secure the keyswitch assembly to the back box using the 2 long screws supplied.

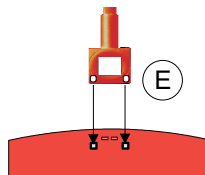

g) Hook the front cover onto the top edge of the keyswitch unit and then push the bottom edge down until it click shut. Check both hooks on the top of the front cover are locked onto the keyswitch assembly.

Operation

To operate the keyswitch insert the operating key into the keyhole 'J' and turn clockwise to the stop position, the red LED 'K' is flashing. The green LED 'I' gives an operating indication.

Apply the reverse procedure to return the keyswitch to a normal operating position.

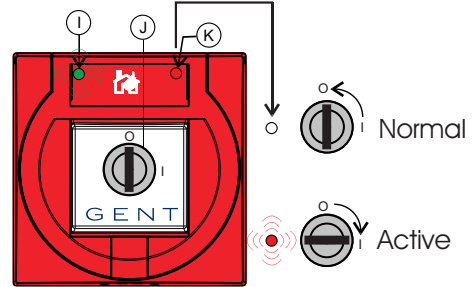

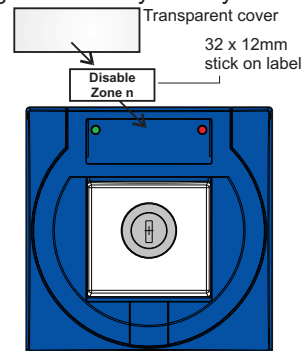

Label

When using the blue keyswitch interface to control plant ensure the unit is labelled to describe what is being controlled by the keyswitch.



It is suggested that an A4 sheet white paper label 32 x 12mm is used, such as the one from RS, part number RS495 385. The required text can be printed onto the label. The label is stuck centrally inside the aperture behind the transparent cover. Ensure LEDs remain visible and are not covered by the label.

 At the end of their useful life, the packaging, product and batteries should be disposed of via a suitable recycling centre and in accordance with national or local legislation.

 **WEEE Directive:**
At the end of their useful life, the packaging, product and batteries should be disposed of via a suitable recycling centre. Do not dispose of with your normal household waste. Do not burn.

Honeywell Gent reserves the right to revise this publication from time to time and make changes to the content hereof without obligation to notify any person of such revisions of changes.

Honeywell GENT	Honeywell Building Technologies, Building 5 Carlton Park, King Edward Avenue, Narborough, Leicester, LE19 0AL	Website: www.gent.co.uk
	Telephone: +44 (0) 203 409 1779	Technical support: www.gentexpert.co.uk