



Operating instructions

Nano panel-based Fire detection and alarm system



Contents

Preface - - - - -	3
Associated documents - - - - -	3
Conventions - - - - -	3
Symbol Keys - - - - -	3
Abbreviations - - - - -	3
User responsibility - - - - -	4
Daily - - - - -	4
Weekly - - - - -	4
Quarterly - - - - -	4
Limitation of false alarm - - - - -	4
Control and indicating equipment - - - - -	5
Control panel - - - - -	5
Repeat panels - - - - -	5
Description of controls and indications - - - - -	6
Navigation - - - - -	8
Normal condition - - - - -	9
How to enter 'Customer mode' PIN for access to Level 2 menus - - - - -	9
Weekly tests - - - - -	10
How to enter the Weekly test mode - - - - -	10
How to exit the Weekly Test mode - - - - -	11
How to view the active Test log - - - - -	11
How to manually raise an alarm of FIRE - - - - -	12
Automatic detection of FIRE - - - - -	13
Coincidence Fire Detection - - - - -	14
Fault condition - - - - -	15
Typical fault messages - - - - -	16
Disablement condition - - - - -	17
Typical Disablement Messages - - - - -	17
To carry out a display test - - - - -	18
How to change time and date - - - - -	18
How to view or print the Historic Events log - - - - -	19
How to view or print active Fire events - - - - -	19
How to view or print active Fault events - - - - -	20
How to view or print active Disablement events - - - - -	20
How to put the system in 'Day mode' or 'Night Mode' - - - - -	21
How to view, enable/disable or test mode a Zone - - - - -	21
How to view or enable/disable an alarm Sector - - - - -	22
How to view the Loop map and Device details - - - - -	22
How to view channel details of interface devices - - - - -	23
How to enable/disable master alarms, fire relay and evacuate input - - - - -	23
How to view the Loop status - - - - -	24
How to view panel 'Firmware' version - - - - -	24
How to view 'Site data' version - - - - -	25
The 'Loop Repair' option - - - - -	25
General Maintenance - - - - -	26
Replacing the glass on a Manual Call Point - - - - -	26
Resetting the resettable element on a Manual Call Point - - - - -	26
Battery replacement - - - - -	26

Preface

This is the seventh issue of the operating instructions for the single loop Nano panel based fire detection and alarms system having Version 2.xx software. It covers all the Customer mode Access level 2 user instructions. This issue has resulted from update to other documents in the document pack.

Associated documents

Nano panel based fire detection and alarm system - Document Pack

Conventions



This is a note to highlight important text that is normally hidden in the main text.



This is either a caution to prevent damage to the equipment or a warning to inform of dangerous conditions that may result in injury or death.

Symbol Keys



What you will see



What you will hear



A fire condition



LED illuminated - On



LED illuminated - Flashing

Abbreviations

LCD - Liquid Crystal Display

LED - Light emitting diode (light)

MCP - Manual call point

PIN - Personal Identification Number
(a password code)

Operating instructions

User responsibility

Your fire alarm system should have been designed, installed and commissioned to your site specific requirements and in accordance with the requirements of BS5839 Part 1. You should have received instructions about your system during the handover stage and must make arrangements to ensure the system is regularly tested and maintained.

It is recommended that the **person responsible** for the fire alarm system should ensure the system is tested and maintained in accordance with the requirements of BS5839:Part 1 and become familiar with:

- the operation of controls and be able to interpret the indications given at the control panel
- keep up to date all documentation associated with the system.



Any servicing work on the system must be carried out by a suitably trained person, please refer to your servicing organisation.

Daily

BS 5839:Part 1, states that the system should be inspected daily to ensure:

- That a normal indication is given at the control and indicating equipment.
- That any previously indicated **fault** conditions have received appropriate attention.
- All system events are entered into the Log Book for future reference.
- That the use of the 'area(s) that are inspected' has not changed since the system was designed.
- That no unsafe practices that could lead to fire are being undertaken.

Weekly

When testing the system there may be a need to isolate ancillary outputs and it is important to contact the alarm receiving centre before and after the weekly test.

- A different **manual call point** of the system should be tested to ensure the system is capable of operating under alarm conditions.
- The operation of the **alarm sounders** should be checked, which also reminds the occupants that there is a fire alarm system which gives a particular sound output.



The test should be performed at a regular time to avoid confusion between a test and a genuine fire alarm. The alarm receiving centre must be contacted before and after the test to check alarms are received and also to avoid unwanted alarms.

Quarterly

At quarterly intervals the system should be inspected and any work necessary should be performed by a trained maintenance engineer.



For help with service and maintenance please refer to your servicing organisation, see contact details entered in the log book.

Limitation of false alarm

It is recommended that the person responsible for the fire alarm system should arrange for suitable investigation and appropriate action on occasion of every false alarm. For a system having less than 40 automatic fire detectors installed, an in-depth investigation should be instigated on occurrence of two false alarms in any rolling 12 months. For a system having more than 40 automatic fire detectors an investigation should be instigated if there has been:

- one false alarm for every 20 installed detectors in the system in any rolling 12 months, or
- two or more false alarm occurrences from a single device.

Control and indicating equipment

On occurrence of a fire, fault or disablement event in the protect premises, the event is quickly indicated at the control panel. The panel controls are password protected and must only be operated by the person responsible for the fire system.

Control panel

The control panel is the heart of the system. It is normally located near to the main entry or exit point of the protected premises. The control panel continuously monitor devices that are connected to the device loop. The device loop cable is routed through the protected premises to cover all areas with both ends of the loop terminating at the control panel. On the loop cable are installed devices such as fire sensors that constantly monitor the environment for fire. Alarm devices on the loop provide alert and evacuation alarm to warn occupants in the protected premises in the event of a fire.



Repeat panels

There may be one or more repeat indicator panels installed in the protected premises to provide secondary indications of the system events. The repeat indicator panels are usually located near to secondary entry and exit points of the protected premises.





Repeat indicator panel











Description of controls and indications

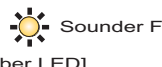

Indicators

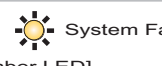
Description

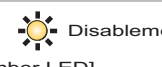
<p>Display</p>	<p>The display provides messages of the system status under normal and event conditions, by means of 8 lines by 40 characters per line display.</p>
<p>POWER  [green LED]</p>	<p>The POWER light when illuminated indicates that a supply to the panel is present.</p>
<p>FIRE  [red LED]</p>	<p>The COMMON FIRE light when illuminated indicates that a FIRE has been detected in the protected premises. The COMMON FIRE light when flashing indicates the external evacuate input is active.</p>
<p>FAULT  [amber LED]</p>	<p>The COMMON FAULT light when illuminated indicates that a FAULT has been detected in the fire detection and alarm system.</p>

	<p>The ZONE 'n' light when illuminated indicates that a FIRE has been detected in the respective zone(s). ('n'=zone number)</p>
	<p>The DELAY light when illuminated indicates that Day Mode delays are setup and active on the panel.</p>
	<p>The VERIFY light when illuminated indicates the verification delay is active.</p>
	<p>The TEST light when illuminated indicates that one or more zones are in Test mode.</p>
	<p>The SOUNDER FAULT light is always illuminated with the FAULT light, which indicates that there is a sounder fault.</p>
	<p>The POWER FAULT light when illuminated indicates the battery or mains supply to the panel has failed.</p>
	<p>The SYSTEM FAULT light when illuminated indicates that a fault has occurred with the system processor.</p>
 <p>It is very important to investigate this fault because the fire alarm system may not be able to detect fires.</p>	
	<p>The DISABLEMENT light when illuminated indicates that a part of the system has been disabled.</p>
	<p>The SOUNDER DISABLEMENT light is always illuminated with the DISABLEMENT light, which indicates that there is sounder disablement.</p>

Controls

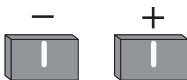
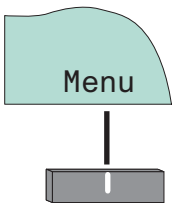





Description

The two selection buttons with a line above allow selection of an option on the display. In this example the option is MENU and on pressing the corresponding button the menu is displayed.

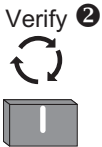
These buttons are used to scroll through a range in a form. They are also used to scroll through the alphabet or number range when entering a label or a PIN code.

Operating instructions

	<p>This button is normally used to highlight the next menu or sub menu option for selection. It is also used to scroll to the next character position when entering a PIN code and similarly when editing a text label.</p> <p>In a fire condition this button is a selection for the 'Verify' option, which is available when the 'Day mode' option is active and the 'Delay LED' is lit. Selecting the 'Verify' option will delay the alarm further to provide the responsible person(s) time to investigate the cause of the alarm and the option of cancelling the alarm within the delay time period.</p>
	<p>The CANCEL BUZZER button when pressed will stop the internal panel buzzer from sounding.</p>
	<p>The SOUND ALARM button will activate all the alarm sounders in the system. This button is only pressed in an emergency or at other agreed times, for example when conducting a sounder test or practice evacuation.</p>
	<p>The SILENCE ALARM button will silence the alarm sounders in the system.</p>
	<p>The RESET button will clear any fire indication and messages and return the panel to its normal condition, providing the devices generating alarm have been cleared for normal operation. If a fire condition occurs immediately after reset then the indicated device should be investigated.</p>

- ① This button may be configured to site specific operation at Access level 1 or Access level 2, latter requiring a Customer mode PIN (factory setting).
- ② These buttons are operable on entry of a Customer Mode PIN code.

Navigation

On selecting the **Menu** option the display shows the user menu.

The functions and submenu options accessible are determined by the access level. The access level 1 is without a PIN code entry, while access level 2 (Customer Mode) or higher access level will require a PIN code entry. Normally the panel is at access level 1.

The instructions covered here are of all those menu options under Access levels 1 and 2.

At any level in a menu momentarily selecting the **Back** option will abort the operation.

At any point in a form selecting the **Quit** option will disregard and not save entries made and return to the menu display. Once a form is filled-in you must select the **Save** option to acknowledge and save any changes made.

If the time taken between button presses exceed a few minutes then the panel will automatically revert to system status indication.

The **Customer Mode PIN code** is programmed during the commissioning of the system and is passed on to the person(s) responsible for the fire alarm system on site.

Normal condition

When the system is operating normally with no fault or disablement condition present then the panel indications are as follows:

- the display will show the Nano system message
- and only the POWER light is lit.

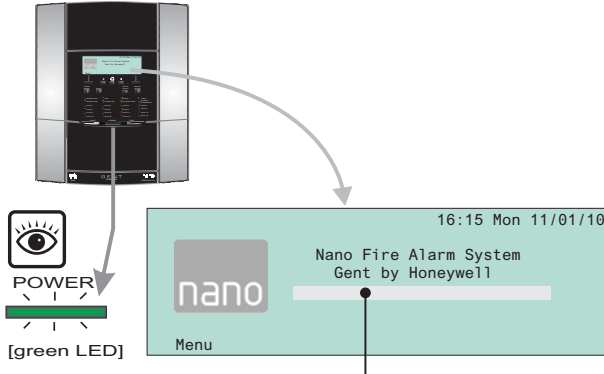

When at access level 2 the display reads :PANEL IN CUSTOMER MODE
 When at access level 3 the display reads :PANEL IN ENGINEERING MODE
 When at access level 4 the display reads :PANEL IN MAINTENANCE MODE

NOTE: The Engineering and Maintenance Modes are not covered in this manual.

How to enter 'Customer mode' PIN for access to Level 2 menus

A Customer mode PIN code is normally set up by the servicing organisation during commissioning of the system. The Customer mode PIN code (password) is for the end user, the person(s) responsible for the fire alarm system. The Customer mode allows access to menu options that are required to be protected by coded entry. It is important the PIN code is changed on a regular basis for security, ask your servicing organisation for advice on changing the PIN code.

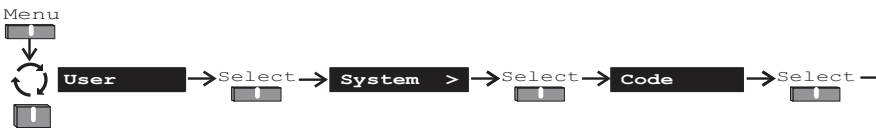

When prompted for a PIN code only these procedures apply.

Use these buttons to scroll to a required number of your PIN from a range 0 to 9. Then repeat the sequence for the next character (or PIN code) position.

To move to the next character (or PIN Code) position.

Accept

User Access Code Entry 10:15 Tue 12/01/10

Enter User Code : [0***]

Accept Quit

Factory set access level code for customer mode is: 0000

Other Access levels exist for engineering use only and are not covered in this document.

Weekly tests

Every week during normal working hours the fire detection and alarm system should be tested. It is important to inform the alarm receiving centre of the fire test. A fire test reminder will appear on the display every week on the specified day if the option is turned on. The fire test should be conducted at a specific time of the day.

A weekly test can be carried out at a manual call point without breaking the call point glass by use of a test key.

How to enter the Weekly test mode

To put the system in a weekly test mode and to identify the next device to be tested, carry out the following procedure at the panel.

First enter the Customer Mode by entering Access Level 2 PIN code, see page 9.

Set the system for 'Weekly Test' by following these procedures.

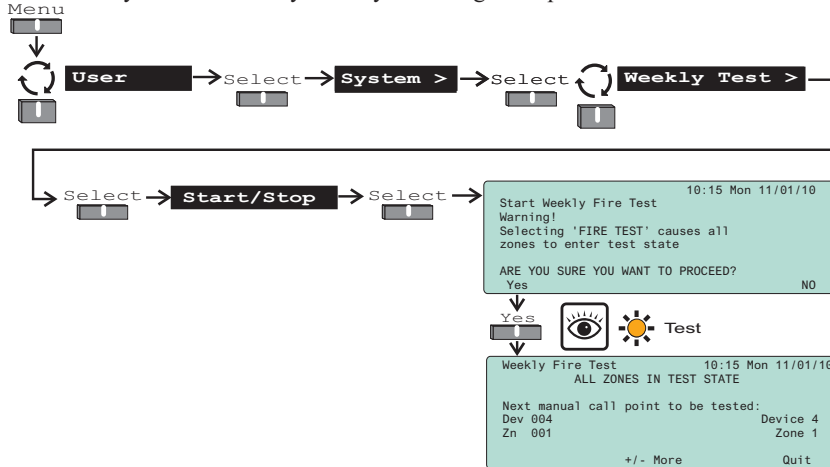

Go to the manual call point to be tested, its green light will be giving a flashing indication. Insert the test key into the Call point keyhole. The keyhole is located on the bottom-centre front face of the call point and is concealed behind a slider cover. Turn the key one quarter of a turn clockwise.

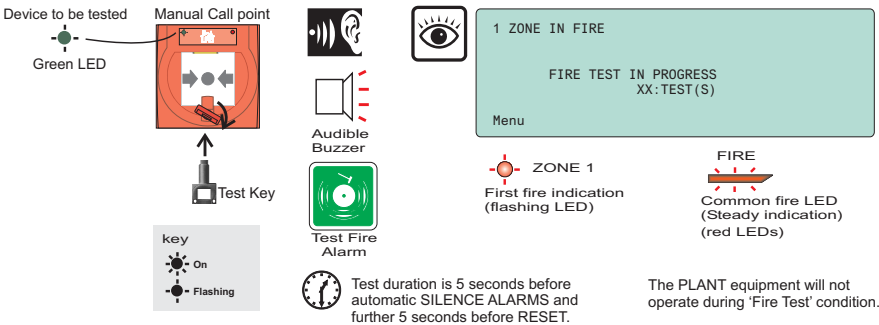

The PLANT equipment will not operate during 'Fire Test' condition.

Check the alarms are sounding in the building and an indication is given of the fire event.

Turn the key anticlockwise one quarter of a turn and remove it from the call point.

Record the event Make an entry in the log book of the event for future reference.

How to exit the Weekly Test mode

When the weekly test is over you will need to exit the weekly test mode.

- Ensure you are still in the Customer Mode at Access level 2, see page 9.
- To exit the 'Weekly Test' follow these procedures.

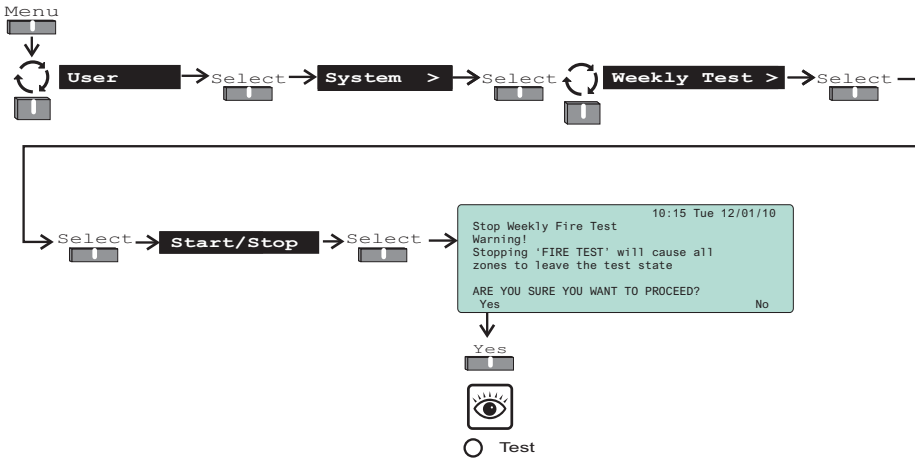

How to view the active Test log

The active test log will show the zones that are in weekly test mode, that is if weekly test is active. Additionally the test log will also show any zone that have been manually placed in test. The 'Test' light will be lit. Follow these procedures to view the Test log:

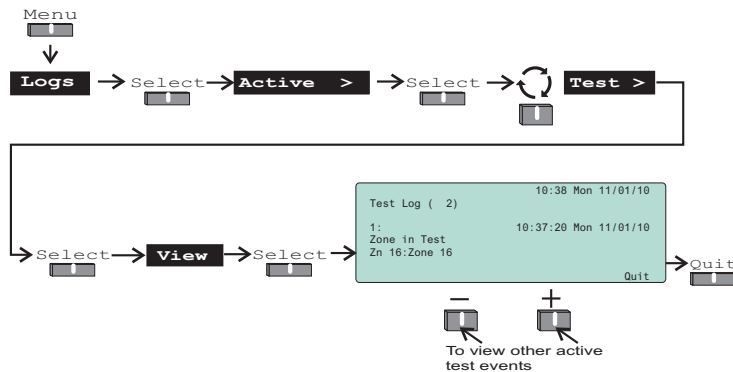

How to manually raise an alarm of FIRE



If you see a fire in the protected premises and want to raise a fire alarm to warn occupants in the building, you can do this manually by:

- going to the nearest manual call point that is located away from the fire hazard.
- press hard with thumb onto the centre of the glass until it breaks.

Manual Call point

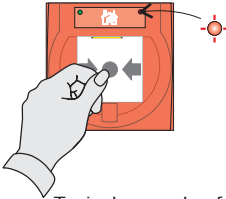

Sound Alarms

At any time you can press the 'Sound Alarms' button to activate alarms site wide. You will need to be in the Customer Mode, see page 9.

Typical example of multiple fires

FAULT:0 DISABLE:1 TEST:0 17:53 Mon 11/01/10
 FIRST FIRE: Zone 1 17:52
 Dv 02 DEVICE 2
 LATEST: Zone 4 17:53
 Dv 03 DEVICE 3
 MA Disabled
 Menu Logout

Displayed if Fault, Disablement or Test Event is present.

ZONE 1
 [flashing indication of first zone in fire]

ZONE 4 + other zone in fire
 [steady indication of other zones in fire]

FIRE
 [Common fire indication] all red LEDs

How to scroll multiple fire events

-
 To view other active events

+

How to cancel the fire buzzer

Cancel Buzzer

Audible Buzzer

MA + Sector X-Y, Z Disabled

Where 'Master Alarm (MA)' and/or alarm 'Sectors' are disabled in the system then they will be displayed in place of 'Total fires'.

NOTE: Where applicable the PLANT equipment will operate in a Fire Condition.

Audible Buzzer

 FIRE ALARM

Key
 On
 Flashing

To operate the alarm controls you will need to be in the Customer Mode at Access level 2, see page 9.

To silence alarms

When the emergency is over the alarm sounders can be silenced.

Silence Alarms



Press:
 Display reads:
 'Alarms silenced'

To reset system

To return the system to normal condition clear any residual smoke or heat from devices, reset any fire inputs and reset Manual call points.

Ensure the fire system is checked by your servicing organisation if there has been fire damage in the protected area.

Reset



Press:
 Display reads: 'Resetting fire - please wait..'

Resets all plant equipment controlled via 'Plant Sectors'.

Record the event Make an entry in the log book of the event for future reference.

Automatic detection of FIRE



A fire in your protected premises is automatically sensed at any one of the fire detection devices installed. A fire detection can be from a fire sensor, manual call point or fire input from an interface. The control panel actions the alarm sounders in the system and at the same time give details of the fire event. The event indication is repeated at all repeat indicator panels in the system.

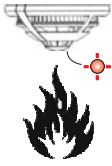

Typical example of a fire event

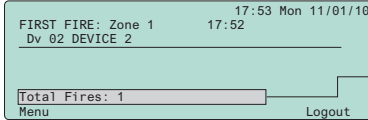

MA + Sector X-Y, Z Disabled
 Where 'Master Alarm (MA)' and/or alarm 'Sectors' are disabled in the system then they will be displayed in place of 'Total fires'.



ZONE 1

[flashing indication of first zone in fire]



ZONE x (other zones in fire)

[A steady indication is given of subsequent zones in fire]

FIRE

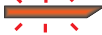

[Common fire indication]

all red LEDs

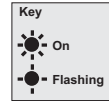

NOTE: PLANT equipment will operate in a Fire Condition.

Multiple fires

The 1st Fire will always appear at the top part of the display. Latest fires appear beneath the 1st Fire message and multiple fires can be scrolled.

The zone light(s) show zones in fire condition. The first zone to go into a fire condition will be indicated by a flashing zone light, all other zones in fire will give a steady indication.

Each fire is logged in the Historic Events log, which can be recalled using the menus. See How to view the Historic Events.



To view other active events Use these buttons to scroll through the fire events.

To operate the following controls you will need to be in the Customer Mode at Access level 2, see page 9.

To activate Verification delay

The 'Verify' option will appear on the display if the 'Delay' light is lit. On selecting the 'Verify' option there is a further delay before alarm activation giving time to investigate the cause of the alarm.



[amber LED]

Verify



Press:

To cancel buzzer

You can stop the panel buzzer from sounding by pressing the CANCEL BUZZER button.

Cancel Buzzer



Press:

Display reads 'Local buzzer cancelled'.

To silence alarms

When the emergency is over the alarm sounders can be silenced by pressing the SILENCE ALARM button. At any time you can resound the alarms by pressing the SOUND ALARMS button.

Silence Alarms



Press:

Display reads: 'Alarms silenced'

To reset system

To return the system to normal condition clear any residual smoke or heat from device(s), reset manual call point(s) and reset any fire inputs. Then press the RESET button.

Reset



Press:

Ensure the fire system is checked by your servicing organisation if there has been fire damage in the protected area.

Resets all plant equipment controlled via 'Plant Sectors'.

Record the event

Make an entry in the log book of the event for future reference.

Zone and Detector Coincidence Fire Detection

If there are area(s) in your protected building configured to operate coincidence fire detection, then the first automatic detection of fire event in that area will cause a FIRE indication at the panel.

When a second fire is detected in the coincidence detection area then the system will go into a FULL FIRE condition and sound the fire alarms.

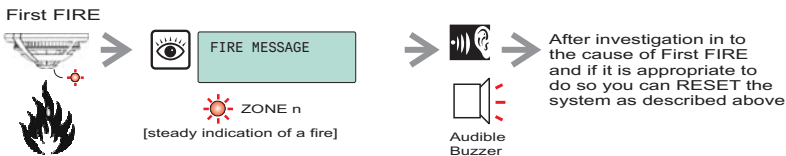

The above indications are given when the system is set up for 'Zone Coincidence' only. A system set up for 'Detector coincidence' will only give a fire message, there is no light indication nor an audible indication on First Fire.

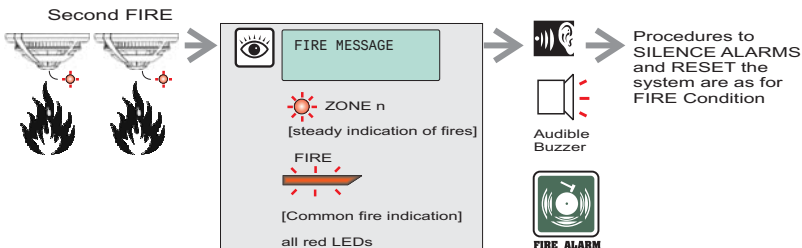

Fault condition

A fault in the system, such as the failure of mains power to the panel or removal of any monitoring device will cause a Fault condition to appear at the control panel. The control panel will provide details of the event, this event indication is repeated at all repeat indicator panels.

Typical indications of Fault events



```

FAULT:6 DISABLE:0 TEST:0          16:15
LATEST FAULT AT 11/01/10 16:15
Device Lost
Dv 145: Room 1 first floor 1
Zn 001: Zone 1
Menu                               Quit
    
```



[amber LED]

Common FAULT indication may be accompanied with:



Audible Buzzer

How to scroll multiple fault events

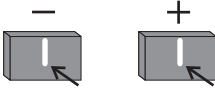

To view other active fault events



[amber LED]



[amber LED]



[amber LED]

You may need to enter the Customer mode PIN, see page 9

To cancel fault buzzer

To stop the panel buzzer from sounding press:



Cancel Buzzer

Display reads:

'Local Buzzer Silenced'

What must be done?

You need to ensure the panel is returned to normal condition.



Only the trained engineer who is responsible for the fire alarm system must attempt any fault rectification work. For advice please call your servicing organisation, see contact details in the Log book.

Record the event

Make an entry in the log book of the event for future reference.

Multiple faults

















On the top line of the display the word *'FAULT'* appears followed by a number 'n'. The 'n' indicates the number of faults present in the system.

Each fault is logged in the Historic Events log, which can be recalled using the menus. See How to view the Historic Events.

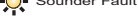
Operating instructions

Typical fault messages

The table below is for guidance only and shows some of the more typical fault messages and indications that may appear at the panel. It also gives the meaning and possible rectification action for each fault event. **Only the trained engineer who is responsible for the fire alarm system must attempt any fault rectification work. For advice please call your servicing organisation, see contact details in the Log book.**

Message	Indication	Meaning	Possible action
Mains supply failed	 	The mains supply to the control panel has failed.	Restore the mains supply to the control panel.
Batteries discharged	 	The battery supply to the control panel has been fully discharged.	Check the battery and replace the battery if necessary.
Batteries disconnected	 	The battery supply to the control panel has been disconnected.	Reconnect the battery supply to the panel.
External Evacuate or Class Change input OC or SC		The Evacuate or Class Change input has an open or short circuit fault.	Check the wiring and ensure the end-of-line devices are connected in the circuit.
Master Alarm(s) OC or SC n	 	There is an open or short circuit fault on the master alarm wiring.	Check the wiring and ensure the end-of-line device is connected to each master alarm circuit.
Lost Device	 	The device is not communicating with the control panel via the Loop. Additional indication is given if it is a Sounder.	Check the connections to the device.
Sensor out of specification		The device indicated is not functioning correctly.	Device needs replacing.
Loop Wiring changed SC		There is a short circuit on the loop wiring.	Identify the device where a cable fault has occurred and remove the fault.
Interface channel OC or SC		There is an open or short circuit fault on the input line of an interface.	Locate and remove the wiring fault. Ensure the end-of-line device is connected to the circuit.
Device Mains failed		There is a mains supply failure at a mains powered interface unit.	Check the fuse and mains supply to the unit.
Device Battery fault		The batteries at mains powered interface unit has failed the load test.	Check the batteries and replace them if necessary.

Disablement condition

A disablement condition is the manual or automatic disablement of a part of the fire detection system. An automatic disablement may be pre-configured for your premises to disable smoke sensors, in areas where smoke may be present for example during the normal working hours. Also a disablement may be necessary where building work is being undertaken that could result in a false alarm.

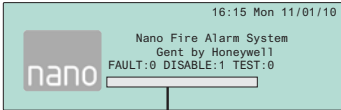

A message is given and the 'Sounder Disablement' light is lit when an alarm sector, sounder device or master alarms are disabled.

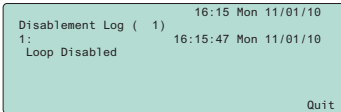

- Disablement
[amber LED]
- Sounder Disablement
[amber LED]

For details of disablement, see How to view or print active Disablement events.

CAUTION: Any changes to the setting of an automatic disablement must only be attempted by a trained engineer who is responsible for the fire alarm system, see contact details in the Log book.

What must be done? Investigate the reason for the disablement and re-enable if appropriate.

Record the event Where necessary make an entry in the log book of the event for future reference.

Multiple Disablements The default page will have the word '*DISABLE*' followed by a number 'n'. The 'n' indicates the number of disablements present in the system. Each disablement is logged in the Historic Events log which can be recalled, using the menus, see How to view the Historic Events log.

Typical Disablement Messages

The following table show some typical disablement messages and indications that may appear at the panel.

Message	Indication	Meaning	Action
Zone Disabled	Disablement	The displayed zone has been disabled.	If manually disabled then investigate and if necessary re-enable the zone.
Device disabled	Disablement Sounder Disablement	The device connected to the loop circuit has been disabled. Additional indication is given if it is a sounder device.	If manually disabled then investigate and if appropriate re-enable the device.
Sector disabled	Disablement Sounder Disablement	The fire alarm sector has been disabled.	If manually disabled then investigate and if appropriate, re-enable the sector.
Master alarm(s) disabled	Disablement Sounder Disablement	The master alarms have been disabled.	If disabled then investigate and if appropriate, re-enable the master alarms.

To carry out a display test

You can test the message display and the lights on the control panel. To operate the 'display test' option you will need to be in the Customer Mode at Access level 2, see page 9. Then carry out the following operation.

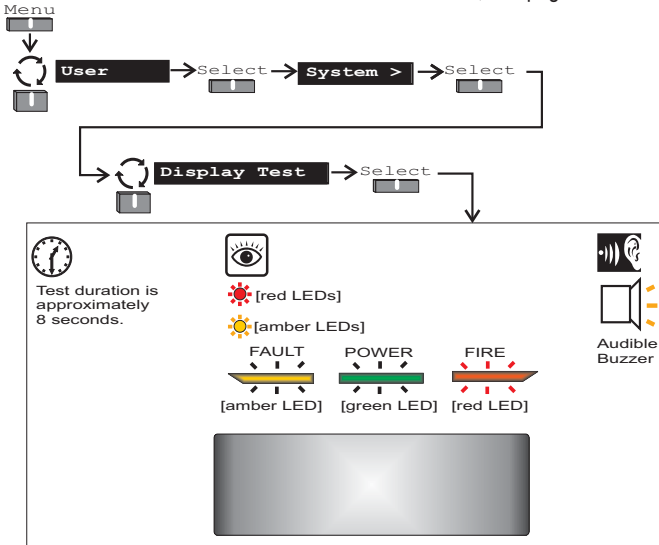

The display will clear, the indicators will illuminate, the buzzer sounds and then the display shows the system status message. The test will run for several seconds.

How to change time and date

The time and date shown on the panel can be changed or adjusted. To make the changes you will need to be at Access level 2, see page 9, then follow these procedures:

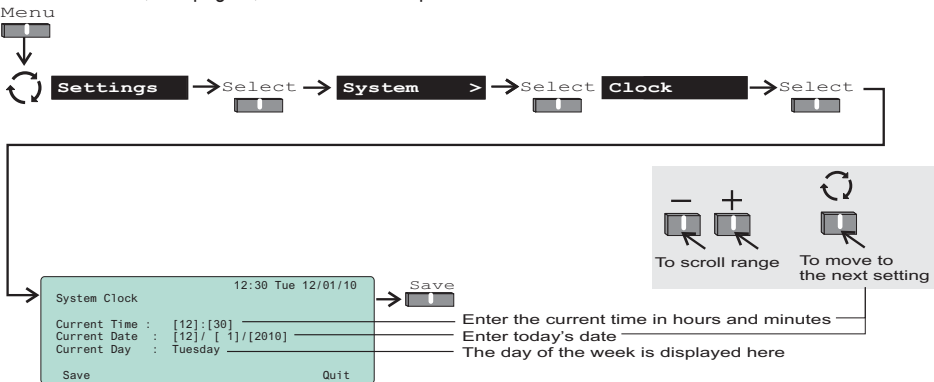

How to view or print the Historic Events log

The past events of the systems are stored in the Historic events log of the panel. To view the Historic events log follow these procedures:

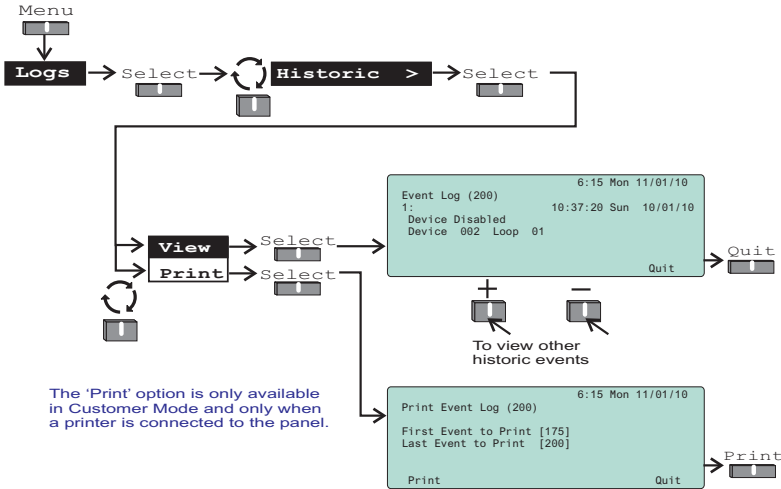

The event number '1' is always the most recent event.

How to view or print active Fire events

All active fire events that are still present and have not cleared can be viewed or printed at any time. The fire lights will be lit at the panel. Follow these procedure to view the fire events log:

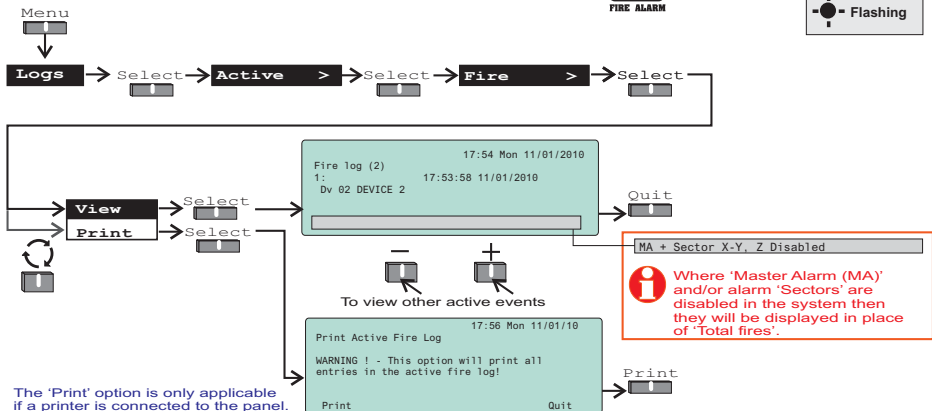
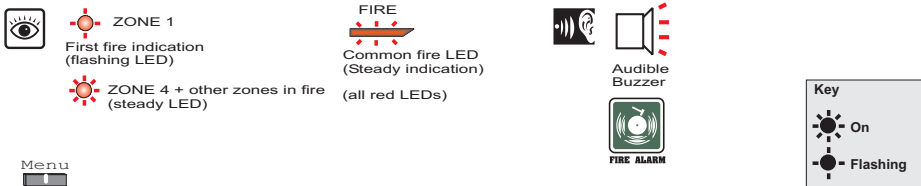

How to view or print active Fault events

All active fault events that are still present and have not cleared can be viewed or printed at any time. The fault light will be lit. Follow these procedures to view the active fault events log:



 Fault
[amber LED]

+ May be accompanied with other Fault indicators

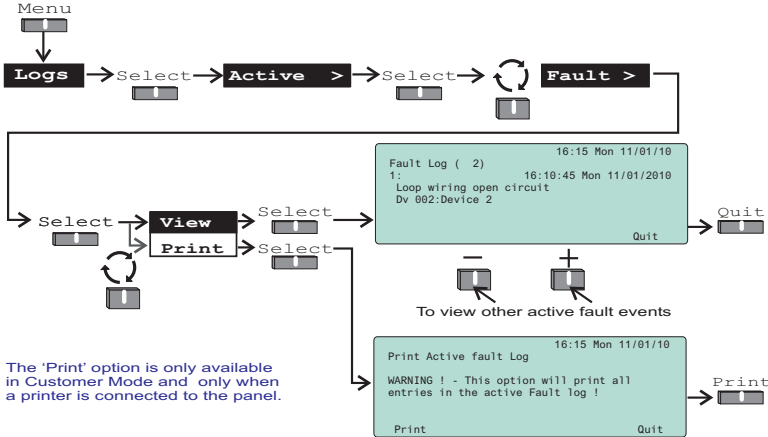

How to view or print active Disablement events

All the active disablement events that are still present and have not cleared can be viewed or printed at any time. The disablement light(s) will be lit. Follow these procedures to view the disablement events log:



 Disablement
[amber LED]

+ Sounder Disablement LED may also be lit

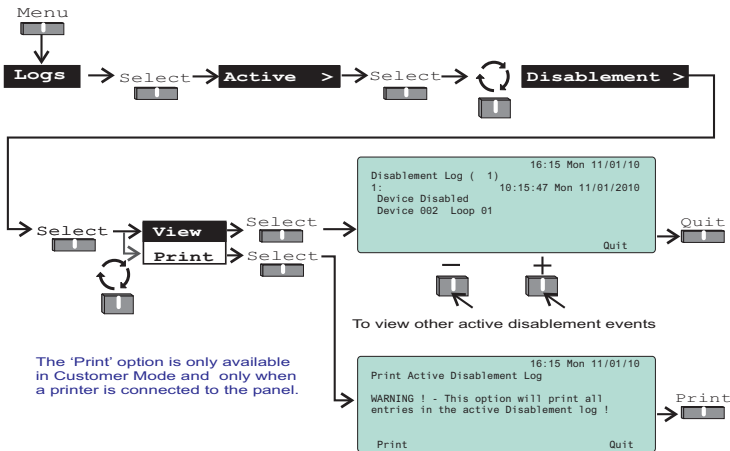

How to put the system in 'Day mode' or 'Night Mode'

The fire system normally operates in the 'Night Mode', which means all the fire alarms operate without a delay in the event of a fire detection. The 'Day Mode' allows a delayed operation of fire alarms. The 'Day mode' is active when the 'Delay' light is lit. The delay durations are programmed to site specific requirements by the servicing organisation. The 'Day Mode' will remain active for a predefined period of time. You can manually place the system in 'Day mode', 'Night Mode' or 'NONE'. Selecting the 'NONE' option will revert the panel delays to operate according to the 'Day mode delay settings' made during commissioning. You will need to be at Access level 2 to change 'Day mode' settings, see page 9.

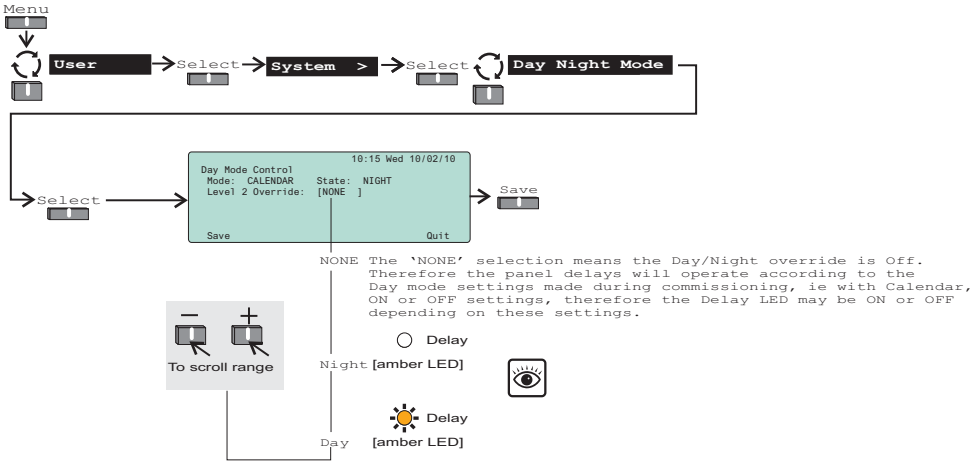

How to view, enable/disable or test mode a Zone

The 'Zone' form allow a zone to be placed in test mode and also allow a zone to be disabled or enabled. Notice the 'Test' light is lit if a zone is in Test mode and the selected zone will function as described for 'weekly test', see page 10. A disabled zone will not detect fires from sensors or manual call points in the zone, the 'Disablement' light will be lit. To access the 'Zone' form you will need to be in the Customer Mode at Access level 2, see page 9.

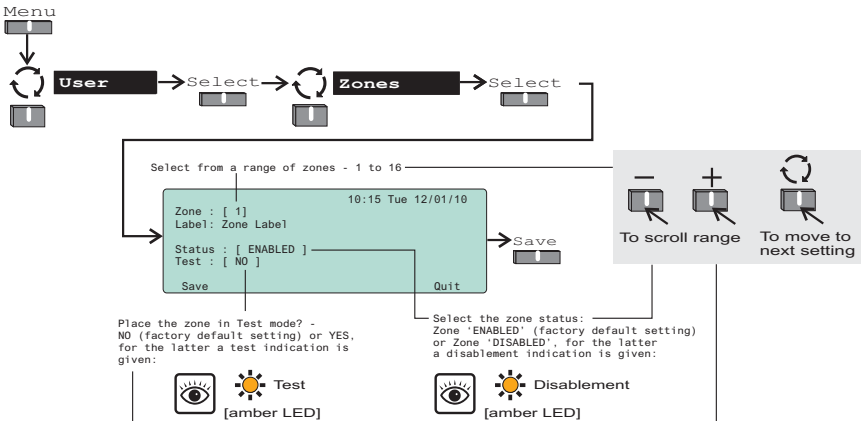

How to view or enable/disable an alarm Sector

The 'Sector' form displays the label given to a sector, its activation control and current status. You can also use this form to manually disable or enable a sector. A disabled sector will not activate its alarm devices in the event of a fire and the disablement light(s) will be lit. To view the 'Sector' form you will need to be in the Customer Mode at Access level 2, see page 9.

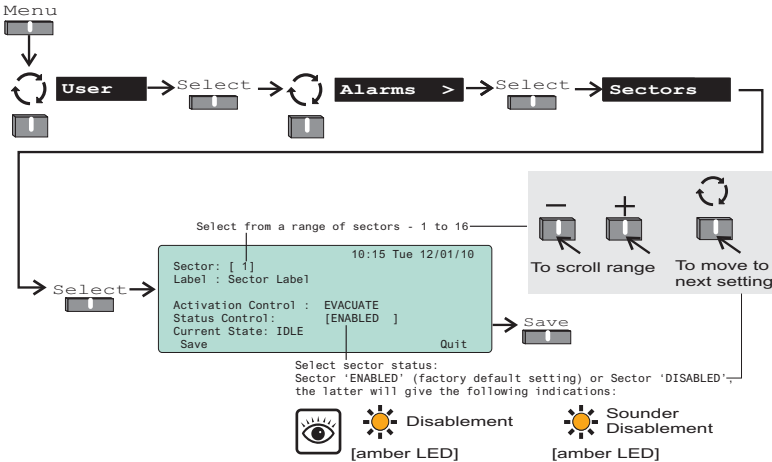

How to view the Loop map and Device details

The 'Loop map' form lists all the devices connected to the loop circuit. You can select a device from the map and view the 'Device details', which gives information on device label, type, status and assignment. To view 'Loop map' and 'Device details' you will need to be in the Customer Mode at Access level 2, see page 9.

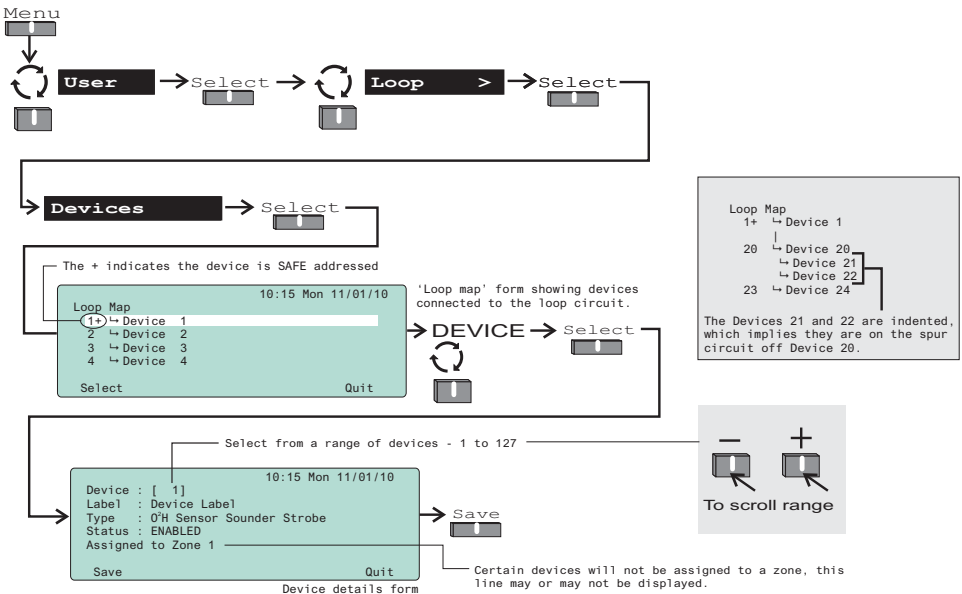

How to view channel details of interface devices

The 'Channels' form show details of a 4-channel interface device on the loop circuit. To view the details of a 4-channel device you will need to be in Customer mode at access level 2.

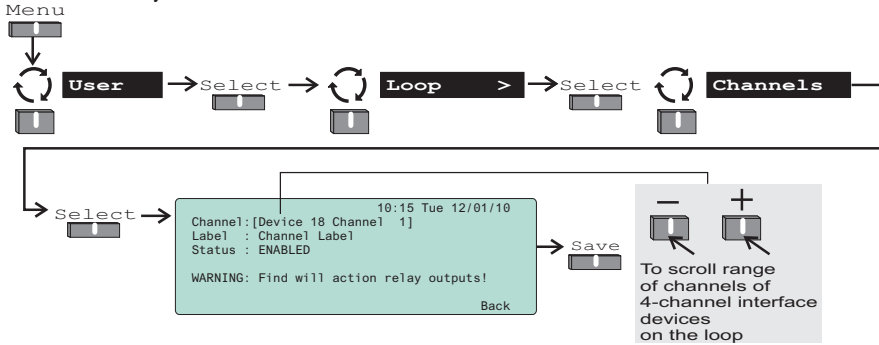

How to enable/disable master alarms, fire relay and evacuate input

The 'Other alarms' form allows the disablement or enablement for Master alarms, Fire relay and Evacuate input. If any of these features are disabled then the 'Disablement light(s) are lit, you will need to be in the Customer Mode at Access level 2, see page 9.

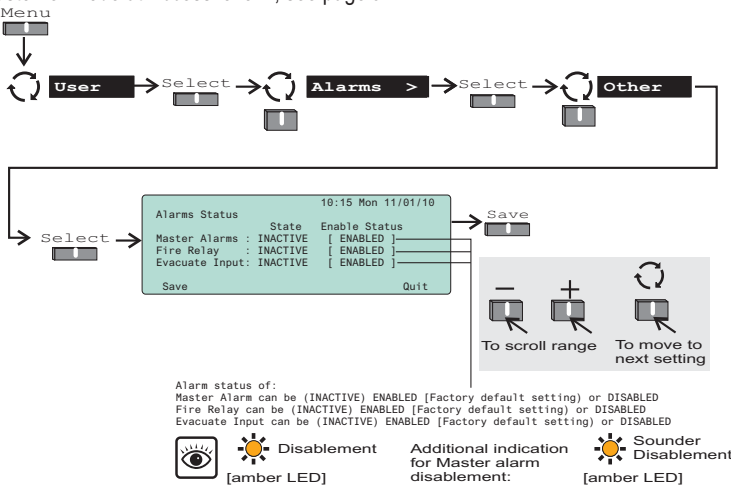

How to view the Loop status

The 'Loop status' form provides information about the number of devices on the loop circuit and the status of the loop circuit. This form is accessible in the Customer Mode at Access level 2, see page 9.

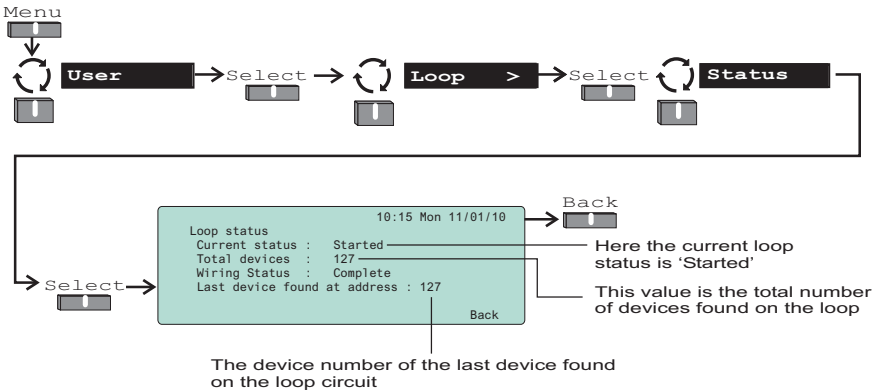

How to view panel 'Firmware' version

To check you have the required panel firmware to support the installed system, you can view the firmware version of the Main Controller, Loop driver and PSU. This form is accessible in the Customer Mode at Access level 2, see page 9.

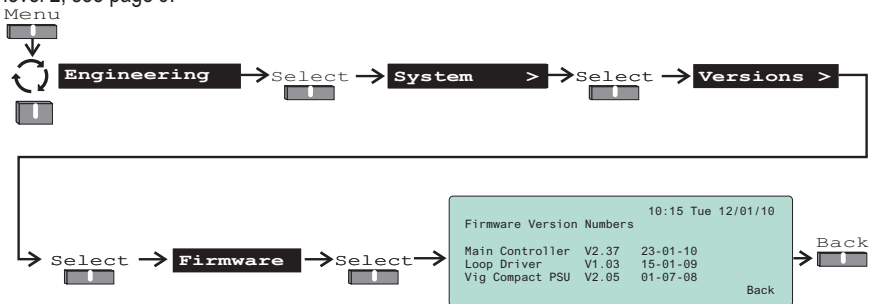

How to view 'Site data' version

You can view site data version. This form is accessible in the Customer Mode at Access level 2, see page 9.

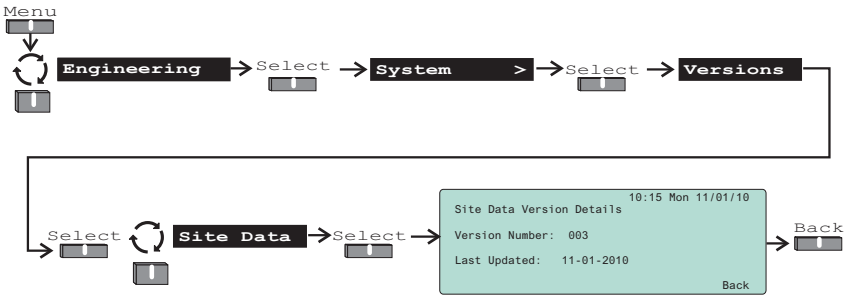

The 'Loop Repair' option



Any wiring fault on the system must be rectified by an engineer from the servicing organisation, for contact details see the log book. A wiring fault will require correction to the wiring before running the 'Repair' option at the main panel.

The 'Loop Repair' option is normally used by a trained person when rectifying wiring faults. Under normal circumstances it is unnecessary to use this option. The 'Repair' option is accessible in the Customer Mode at Access level 2, see page 9.

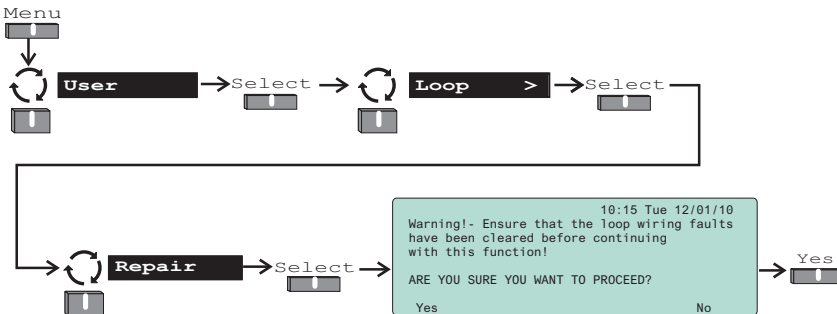

General Maintenance

Replacing the glass on a Manual Call Point

- Disengage the front cover from the call point assembly using the end of the test key. Insert the key into the slots 'E' and from the bottom edge lift out the cover.
- Carefully remove broken glass.

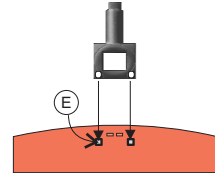

Take appropriate precautions when clearing broken glass to prevent injury.

- Turn the test key such that the tab is at position 'F' and insert a new glass as shown.
- Hook the front cover onto the top edge of the call point assembly and then push the bottom edge down until it clicks into position. Check both hooks on the top of the front cover are locked onto the call point assembly.
- Turn the test key anticlockwise one quarter of a turn such that the glass is held under the yellow arm.

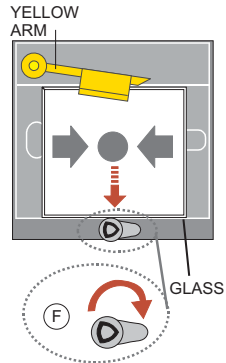

S4-34891 Spare MCP glass (Pack of 10)

Resetting the resettable element on a Manual Call Point

Slide the cover upwards to expose the key hole. Insert the test key in the keyhole and turn it clockwise by one quarter of a turn. Then turn the test key anticlockwise by one quarter of a turn to reset the call point element.

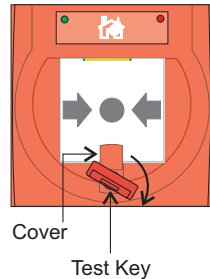

Battery replacement

It is recommended where batteries are installed they must be replaced at 4 Yearly intervals from the date the system is first commissioned.



Any servicing work on the system must be carried out by a suitably trained person, such as an engineer from the servicing organisation.

Quick Reference How to Silence Alarms and Reset system

Silence Alarms

On pressing the button you will be prompted to enter your password (a PIN Code) to access emergency controls.



Use the - and + keys to scroll the number range to show the first PIN number and then repeat the sequence for the next character (PIN code number) position. On entry of all 4 digits select 'Accept'.

Enter User Code : 0****

(The factory set PIN for Customer mode is: 0000)



To move to the next character position (PIN code number) position.

To Silence Alarms



At any time you can press the "Sound Alarms" button to activate alarms site wide. You will need to be in the Customer Mode

To Reset System



To reset and return the system to normal condition first clear:

- any residual smoke or heat from devices
- reset any fire inputs and
- reset Manual call point(s)

Ensure the fire system is checked by your servicing organisation if there has been fire damage in the protected area.

To cancel the panel Buzzer



To activate Verification delay IF APPLICABLE

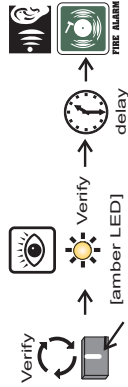

At the end of their useful life, the packaging, product and batteries should be disposed of via a suitable recycling centre and in accordance with national or local legislation.



WEEE Directive:
At the end of their useful life, the packaging, product and batteries should be disposed of via a suitable recycling centre. Do not dispose of with your normal household waste. Do not burn.



0832

Gent by Honeywell
Hamilton Industrial Park, 140 Waterside Road, Leicester LE5 1TN, UK
0832-CPD-1257
NANO-24

EN54-2: 1997, A1:2006

Control and Indicating equipment for fire detection and fire alarm systems in buildings.

7.8 Output to fire alarm devices

7.11 Delays to action outputs

8.3 Fault signals from point

10 Test condition

EN54-4: 1997, A1:2002, A2:2006

Power supply equipment for fire detection and fire alarm systems in buildings.

Gent by Honeywell reserves the right to revise this publication from time to time and make changes to the content hereof without obligation to notify any person of such revisions of changes.

GENT
by Honeywell

Hamilton Industrial Park, Waterside Road, Leicester LE5 1TN

Telephone: +44 (0)116 246 2000

Website: www.gent.co.uk

Fax (UK): +44 (0)116 246 2300

