

## Data and Installation Instructions

### Nano panel-based Fire detection and alarm system



## Contents

Contents - - - - -	2	Repeat indicator panel - - - - -	21
Preface- - - - -	3	External Evacuation input - - - - -	22
Associated Documents · · · · ·	3	Class Change input - - - - -	22
Conventions · · · · ·	3	RS232 Port- - - - -	22
Abbreviations - - - - -	3	USB Port- - - - -	22
Notes on system installation - - - - -	4	Battery installation - - - - -	23
Installation requirements - - - - -	4	On completion of panel installation - - - - -	24
Second fix - - - - -	4	Nano panel parts- - - - -	25
Fixture and fittings - - - - -	4	Control Panel- - - - -	25
As fitted drawings - - - - -	4	Printer - - - - -	25
Cable type and routing - - - - -	4		
Fire sensor cover - - - - -	4		
Earth continuity - - - - -	4		
Power supply- - - - -	4		
Mains supply - - - - -	4		
Devices - - - - -	4		
Local Manual Call Point - - - - -	4		
EN54 information - - - - -	5		
Optional functions with requirements of this European standard - - - - -	5		
System wiring - - - - -	5		
Cable separation - - - - -	5		
Lightning protection · · · · ·	5		
Requirements of cables - - - - -	6		
Mains Supply cable- - - - -	6		
Repeat indicator to Control panel cable - - - - -	6		
Loop Cables - - - - -	6		
Enhanced loop cables · · · · ·	6		
Standard loop cables · · · · ·	6		
Devices per Device loop - - - - -	7		
Nano System Architecture- - - - -	9		
Nano panel - - - - -	10		
Features · · · · ·	10		
Technical data - - - - -	11		
Control panel · · · · ·	11		
Power supply · · · · ·	12		
Panel installation - - - - -	13		
How to disassemble the panel to gain access to the Backbox - - - - -	13		
How to mount the backbox and use of dedicated cable entry points - - - - -	14		
Flush Mounting the backbox - - - - -	15		
Refitting the electronics module - - - - -	15		
Cable termination on enclosure - - - - -	16		
Wiring test · · · · ·	16		
Mains supply- - - - -	17		
Mains and battery supply connections · · · · ·	17		
Removable terminal blocks - - - - -	17		
Terminals for external circuits on Main Control Board - - - - -	18		
Device loop circuit - - - - -	19		
Master alarm circuits - - - - -	20		
Common Fault contacts - - - - -	20		
Fire Output contacts - - - - -	21		

## Preface

This is the eleventh issue of the Installation instructions for the **Nano panel based system** with information on products that are compatible with panel Version 3.xx software. This issue now cover EN54 Part 23 devices and battery standby calculation. This issue contains explanation of symbols on product, change to Notified body number and LVD updates. Zone input from loop interfaces updated.

These instructions must be read in conjunction with the recommendations in *BS5839:Part 1*, which is the *code of practice for Fire detection and alarm systems for buildings*.

## Associated Documents

Document Pack, includes:

- Operating instructions
- Installation instructions
- Log book
- Quick ref. / Template.

## Symbols on product



Electric shock hazard.



Protective Earth connection terminal.



The WEEE symbol. It indicates the product is to be recycled and not thrown away.



The CE compliance logo. This product is in conformity with the relevant European Union harmonisation legislation.

**RoHS** The RoHS compliance logo. The RoHS directive restricts the use of certain hazardous substances commonly used in electronic and electronic equipment.



The UKCA (UK Conformity Assessed) marking is a new UK product marking that is used for goods being placed on the market in Great Britain (England, Wales and Scotland).

## Abbreviations

ac - Alternating current  
 AS - Anti surge  
 dc - Direct Current  
 EOL - End of line  
 EP - Environmentally protected  
 GND - Ground  
 I/F - Interface  
 IO or I/O - Input Output  
 IP - Ingress protection  
 LCD - Liquid crystal display  
 LED - Light-emitting diode  
 LPCB - Loss prevention council certification board  
 LV - Low voltage  
 MCP - Manual call point  
 MICC - Mineral insulated copper cable  
 N/C - Normally closed  
 N/O - Normally open  
 OC or O/C - Open circuit  
 OH - Optical Heat  
 OHCO - Optical Heat Carbon DiOxide  
 PCB - Printed circuit board  
 PIN - Personal identification number  
 (Usercode, password or access code)  
 PSU - Power supply unit  
 SC or S/C - Short circuit  
 T - Anti-surge (fuse)  
 VAD - Visual Alarm Device  
 USB - Universal Serial Bus

## Conventions



This is a note to highlight important text that is normally hidden in the main text.



This is either a caution to prevent damage to the equipment or a warning to inform of dangerous conditions that may result in injury or death.

# Notes on system installation

The power-up of the control panel and commissioning of the system is done by the Servicing organisation.

### Installation requirements

It is recommended that the installer follow the general requirements of BS 5839 : Part 1 : 2013, which is the code of practice relating to fire detection and alarm systems for buildings. The installer must follow the relevant parts of BS 7671 : 2008 Requirements for Electrical installations, IEE wiring regulations 17th edition if installation is in the UK.

### Second fix

To prevent the possibility of damage or dirt degrading the performance or appearance of the products, the installation of the panel should be delayed until all major building work in the area is complete.



**The installation of all outstanding parts and panel the power up is usually carried out during system commissioning.**

### Fixture and fittings

It is the installer's responsibility to provide adequate fixtures and fittings for the type of construction surface onto which a product is to be mounted, whilst utilising the fixing points on the product. As an aid to this decision, the weight and overall size of each full assembly together with implications on cable entries and routing should be taken into consideration.



**All these procedures assume that the cable, gland, steel box (BESA box) and other related accessories are provided by the installer. Also the cable glands used must meet the UL94V-1 or better flammability rating.**

### As fitted drawings

The installer should acquire site specific information from the interested parties, for details on the location of products for installation. The acquired information together with this guide and the relevant standards should be used to assist the work. Each product assembly can be identified from its package label. The contents of all packages should be checked for any discrepancies.

### Cable type and routing

Appropriate attention must be given to ensure the correct cable type is installed in accordance with 'as fitted drawings', site specific information and recommendations of BS5839 Part 1 : 2013. The cables must be installed using cable manufacturers recommended fixing and accessories.

### Fire sensor cover

Each fire sensor may be supplied with a plastic dust cover. The cover must be fitted to prevent dust and dirt from the building work contaminating the fire sensor.

### Earth continuity

All earth connection points should be **clean to provide a good electrical conductivity path. To maintain the earth continuity: all earth leads and fittings** provided should be installed. The **loop cable** screen must be continued through each system device on the loop circuit, whether the earth is connected to the device or not.



**Do not use any part of building structure for earthing.**

Some of the system products having metal enclosure with **zinc coating** around the cable termination points, the coating provides a good electrical conductivity path for cable earth termination. The zinc coating on metal enclosures should not be damaged. Any damage will expose bare metal, which can corrode and make a poor earth connection.

### Power supply

The power to the system is derived from the mains and battery supplies. Before removal of the electronic module from the panel or disconnection of any cable from the board ensure both mains and battery supplies are disconnected.

### Mains supply

Mains supply to any fire alarm control and indicating equipment must be via an unswitched 5A fused spur unit. A disconnect device must be provided to disconnect both poles and must have a minimum gap of 3mm. The disconnect device should be available as part of the building installation and must be easily accessible after installation is complete.



**All mains powered equipment must be earthed.**

### Devices

Always install new devices on the loop circuit. Never use devices that have been previously installed on the loop circuit of another system.

### Local Manual Call Point

To comply with the requirements of EN54-2 : 1997 a manual call point must be installed near the control panel. The call point when activated must be set up to sound all alarms without delay.



**Failure to install and configure a local manual call point in the manner described above when delays are set up on the system will result in the panel not complying to EN54- 2 : 1997.**

# EN54 information

## Optional functions with requirements of this European standard

The Control panel complies with the requirements of EN54 : Part 2 : 1997. In addition to the basic requirements of the standard the panel conforms to the following optional clauses:

Clause	Description
7.8	Output to fire alarm devices
7.11	Delays to action outputs
8.3	Fault signals from point
10	Test condition

## System wiring

If instructed, the installer may need to terminate as well as connect the cables to the appropriate terminal blocks.

### Cable separation

Where the outgoing and return cables of a loop circuit covers more than the equivalent of one zone they must **not** run together, for example, either close to the **Control Panel** or in a **service duct**. There should be as much physical separation as possible between the cables and the mechanical protection of the cable should be to a particularly high standard. This is to minimise the risk of accidental damage to both cables.

### Lightning protection

Where a loop cable is mounted to an external wall or between two buildings then consideration should be given to the use of lightning protection devices.

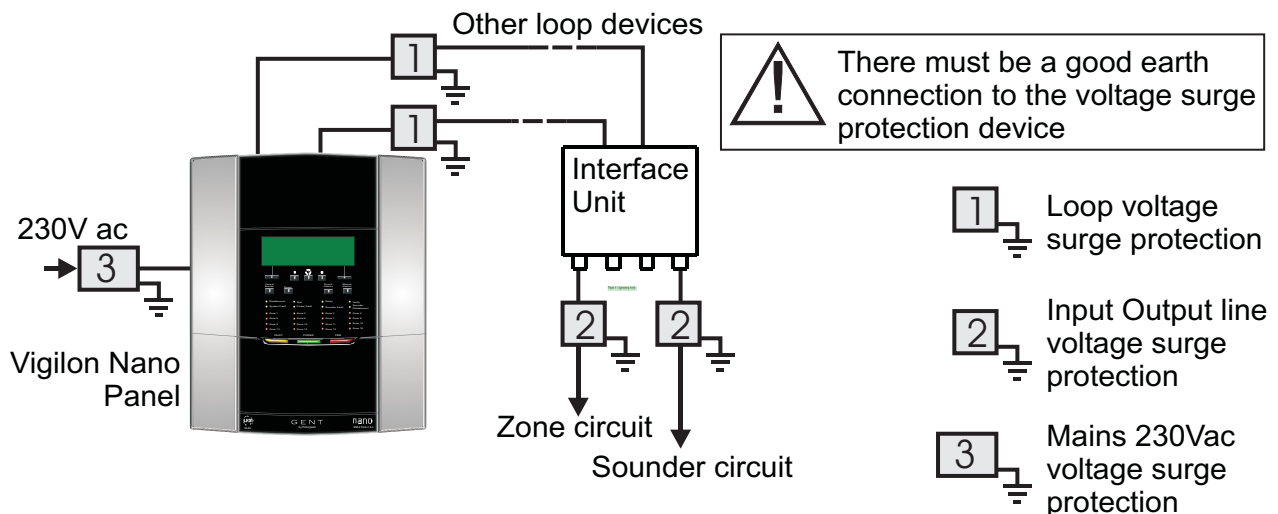

## Installation instructions

### Requirements of cables

The *British Standard BS5839 Part 1 : 2013 Code of practice for system design, installation, commissioning and maintenance* states the requirements for standard and fire resisting cables in Clause 26.2 section d and e.

"d) **Standard fire resisting cables** should meet PH 30 classification when tested in accordance with EN50200 and maintain circuit integrity if exposed to the following test:  
- a sample of the cable is simultaneously exposed to flame at a temperature of 830°C- 0+40°C and mechanical shock for 15min, followed by simultaneous exposure to water spray and mechanical shock for a further 15min.

e) **Enhanced fire resisting cables** should meet the PH120 classification when tested in accordance with EN 50200 and maintain circuit integrity if exposed to the following test:  
- a single sample of the cable is simultaneously exposed to flame at a temperature of 930°C - 0+40°C and mechanical shock for a period of 60min, followed by simultaneous exposure to water spray and mechanical shock for a further 60min."

### Mains Supply cable

The mains supply cable must be a standard fire resisting type and should meet PH30 classification, such as standard and or enhanced cables.

### Repeat indicator to Control panel cable

A maximum of 1Km cable distance is allowed between Control Panel and Repeat indicator panel

- Belden No. 9842 EIA RS485 Applications, O/A Beldfoil® Braid having two twisted pairs.

### Loop Cables



There is a maximum limit of 1Km loop cable usage allowed per loop circuit. This maximum limit is the sum of the cable used on main loop circuit, spurs off main loop circuit, plus cable runs to all input / output lines off loop powered interface units installed on the loop.

There is a further maximum limit of 100m cable run allowed per input/output line off loop powered interface unit.

A loop cable carries both data and power, therefore its selection is important. Note the following:

- In countries where the European EMC directive is in force, only **EMC Compliant** cables are to be used.
- The loop cable usage must not exceed **1Km**. This includes the cable used on main loop and spur circuits.
- Single pair cable must be used. It is **NOT** permissible to run mixed loops or outgoing and return pairs in a multi core cable, due to inadequate separation and possible electrical interference problems.
- Each core of the loop cable must be **1.5mm<sup>2</sup>** cross section area.
- The cable screen must be **capable** of being earthed at each system device.

- Red** is the preferred cover sheath for fire applications.
- The specified loop circuit cables are **also suitable** for wiring master alarm, auxiliary relay, input/output lines and mains supply.

### Enhanced loop cables

*Approved cables for loop wiring (EMC Compliant)*

- Draka Firetuf FT120 **Enhanced** - FTPLUS2EH1.5RD (formally Firetuf FT Plus)
- Datwyler Pyrofil **Enhanced**
- Mineral insulated cable (MICC) to BS6207:Part 1
- Prysmian (previously Pirelli) **FP PLUS \***

### Standard loop cables

*Approved cables for loop wiring (EMC Compliant)*

- AEI Cables **FIRETEC \***
- Alcatel cable **PYROLON E \*** distributed by Winstonlead
- BICC Pyrotenax **FLAMESIL FRC \***
- Cavicel SpA **FIRECEL SR 114H \*** distributed by Cables Britain
- Datwyler Pyrofil **Standard \*** (previously LIFELINE)
- Draka Firetuf EMC Standard 1.5mm<sup>2</sup> **FTEMC2EH1.5RDR**
- Draka Firetuf **FTES2EH1.5** (previously FTZ2E1.5 FIRETUF OHLS \*) fire resistant data cable
- Huber & Suhner **RADOX FR \***
- Prysmian (formally Pirelli) **FP200 FLEX \***
- Prysmian (formally Pirelli) **FP200 GOLD \***
- Raydex CDT **FG950 \***



The cables marked \* utilise laminated aluminium tape with a tinned drain wire for electrostatic screening. Under certain environmental conditions **galvanic action** may take place between the aluminium and the drain wire. This will severely **degrade EMC performance** as the foil to drain wire **impedance will increase**. Armoured variants of these can also be used for wiring a loop circuit.

## Devices per Device loop



**It is important that redundancy is built into the system to accommodate future expansions.**

The number of devices on the loop circuit can be limited by the total number of addresses available, the electrical load on the circuit, the maximum cable length and other geographical considerations.

- The loop circuit must not coverLoad factors adn more than **10,000m<sup>2</sup>** of floor area of a protected site.
- In total a maximum of **127** devices are allowed on the loop circuit.
- As a general rule allow **1000** load factor for the loop circuit and only use the 2nd value when calculating the maximum load factor.

**The following table can be used as a guide to determine loop load.**



**Take note of the number of interfaces / modules allowed per loop, see table below. The Battery Standby Calculator is built into the Commissioning tool, which should be used during system design stage to determine the loop loading. The tool can be downloaded from the Gent Expert forum ([www.gentexpert.co.uk](http://www.gentexpert.co.uk)), which is accessible to registered users.**



**All the 'High perform.' and 'Standard perform'. S-Cubed devices and (HP) S-Quad devices all revert to LOW VAD performance devices when installed in a Nano panel based system. Only the LOW VAD setting of the device is used in a Nano system.**

Device code number	Description	Load factor per device	Maximum devices on the loop
S3-S-R	S3 Sounder / Red Body	5	127
S3-S-W	S3 Sounder / White Body	5	127
S3-V-R	S3 Voice Sounder / Red Body	17.5	55
S3-V-W	S3 Voice Sounder / White Body	17.5	55
S3-VAD-HPW-R	S3 VAD / High perform. White VAD / Red body	25	40
S3-VAD-HPR-R	S3 High perform. Red VAD / Red Body	18	35
S3-S-VAD-HPW-R	S3 Sounder / High perform. White VAD / Red Body	28	35
S3-S-VAD-HPW-W	S3 Sounder / High perform. White VAD / White Body	28	35
S3-S-VAD-LPW-R	S3 Sounder / Standard perform. White VAD / Red Body	28	35
S3-S-VAD-HPR-R	S3 Sounder / High perform. Red VAD / Red Body	18	55
S3-S-VAD-HPR-W	S3 Sounder / High perform. Red VAD / White Body	18	55
S3-S-VAD-LPR-R	S3 Sounder / Standard Perform. Red VAD / Red Body	18	55
S3-V-VAD-HPW-R	S3 Voice Sounder / High perform. White VAD / Red Body	32	30
S3-V-VAD-HPR-R	S3 Voice Sounder / High perform. Red VAD / Red Body	21.5	45
S3EP-S-R	S3 Sounder / Red Body / EP	11.25	88
S3EP-VAD-HPW-R	S3 VAD/High perform. White VAD / Red Body / EP	25	40
S3EP-VAD-HPR-R	S3 VAD/High perform. Red VAD / Red Body / EP	18	35
S3EP-V-VAD-HPW-R	S3 Voice Sounder / High perform. White VAD / Red Body / EP	32	30
S3EP-V-VAD-HPR-R	S3 Voice Sounder / High perform. Red VAD / Red Body / EP	21.5	45
S4-34800-EN	Manual Call Point	3	127
S4-34805-EN	Manual Call Point	3	127

## Installation instructions

Device code number	Description	Load factor per device	Maximum devices on the loop
S4-34410	1 - LV Input interface module including. zone # excluding zone # - The 'including zone' Zone input functionality of this interface is not supported on NANO Loop.	n/a 1	n/a 100 ~
S4-34450	4 - LV Input / Output interface module including. zone # excluding zone # - The 'including zone' Zone input functionality of this interface is not supported on NANO Loop.	n/a 5	n/a 8, see Note
S4-34420	1 - LV Output Interface module	1	127, see Note
S4-34411 / S4-34415	1 - MV Output Interface module	1	127, see Note
S4-34440-12	Mains powered interface	1	8, see Note
S44404	Mains switching interface	5	8, see Note
S4-34418	Keyswitch interface	4	127, see Note
S4-720	S4 Heat	0.5	127
S4-715	S4 Optical	0.5	127
S4-710	S4 Optical & Heat	0.5	127
S4-711	S4 Dual Optical & Heat	0.5	127
S4-711-VAD-HPR	S4 Dual OH/Red VAD (HP)	10	100
S4-720-V-VAD-HPR	S4 Heat / Voice Sounder / Red VAD (HP)	17.5	55
S4-711-V-VAD-HPR	S4 Dual OH / Voice Sounder / Red VAD (HP)	17.5	55
S4-911-V-VAD-HPR	S4 Dual OHCO / Voice Sounder / Red VAD (HP)	17.5	55
S4-711-VAD-HPW	S4 Dual OH/White VAD (HP)	10	100
S4-711-V-VAD-LPW	S4 Dual OH / Voice Sounder / White VAD (LP)	17.5	55
S4-711-V-VAD-LPR	S4 Dual OH / Voice Sounder / Red VAD (LP)	17.5	55
S4-711-V-VAD-HPW	S4 Dual OH / Voice Sounder / White VAD (HP)	17.5	55
S4-720-V-VAD-HPW	S4 Heat / Voice Sounder / White VAD (HP)	17.5	55
S4-911-V-VAD-HPW	S4 Dual OHCO/Voice Sndr./White VAD (HP)	17.5	55
S4-711-V	S4 Dual OH / Voice Sounder	8.25	120
S4-770-S	S4 OH / Sounder	6.5	127
S4-771-S	S4 Dual OH / Sounder	6.5	127
S4-780-S	S4 Heat / Sounder	6.5	127
S4-901	S4 Dual OH CO	0.5	127
S4-34760	Venturi-Air Duct Kit	0.5	127
S4-34740	Beam sensor pair (16 sensor heads + 8 pair)	3 per pair	8 pair
34701	Tee breaker	0.5	127







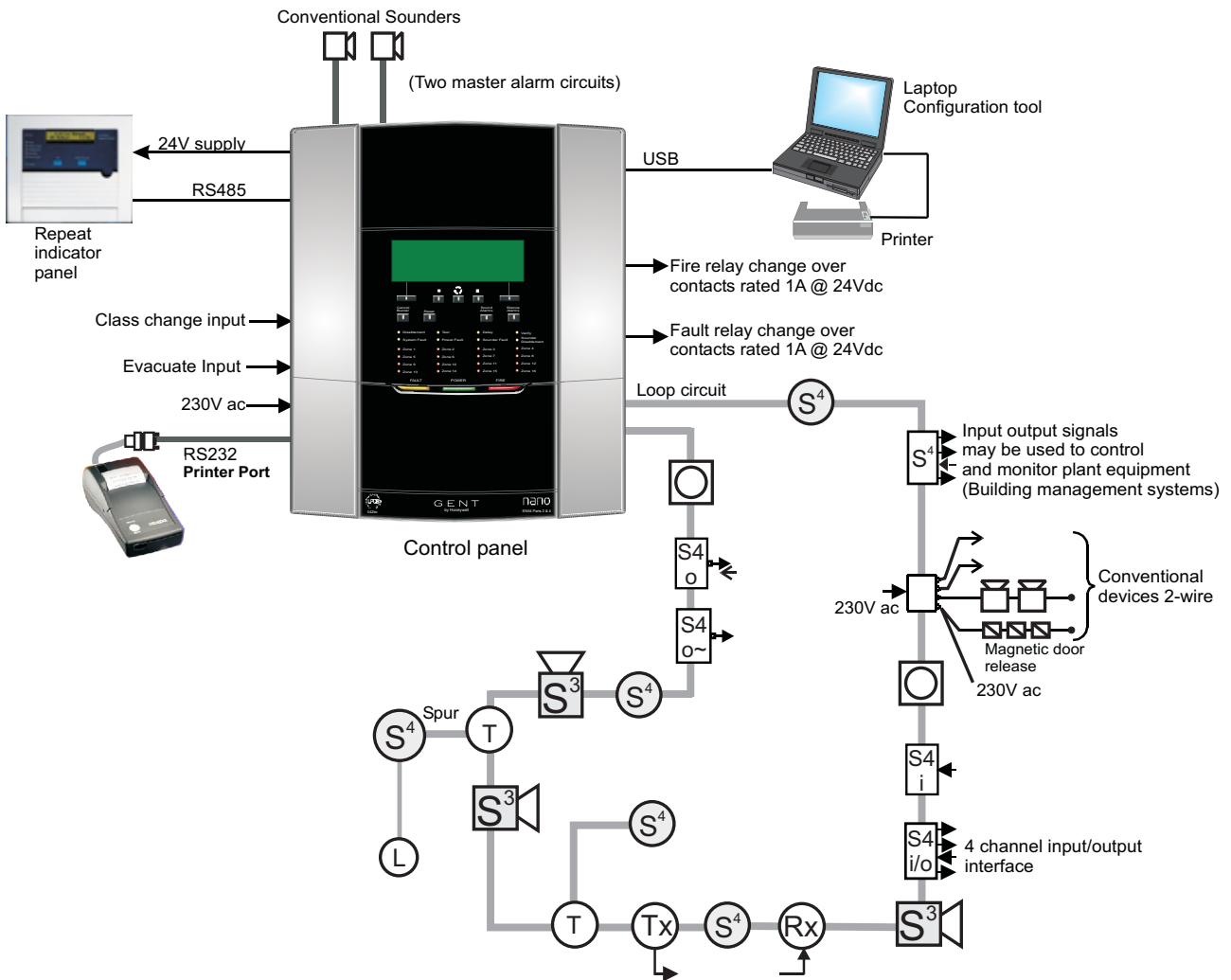



The maximum devices per loop and load factor per device have been revised due to changes in product specification.

## Nano System



The loop circuit allows wiring of addressable devices like **fire sensors, alarm sounders, manual call points and interface units**, a combined maximum of up to **127** devices is allowed on the loop circuit.



### Addressable System Devices

-  - S-Quad Sensor Speech Sounder & Strobe
-  - S-Cubed Voice enhanced Speech, Sounder, Strobe Unit
-  - Manual Call Point
-  - T Breaker
-  - Beam sensor Transmitter and receiver
-  - S4 4-Input/Output loop powered interface
-  - S4 1-Input loop powered interface
-  - S4 1-Output + Confirmation input loop powered interface
-  - S4 Mains switching output loop powered interface
-  - 4 - Input/Output mains powered interface unit

### Conventional Products off interface inputs

-  - Magnetic door release
-  - Alarm sounder

### LED off S<sup>4</sup> sensor

-  - Remote LED

# Nano panel



## Features

- Single loop fire control panel
- Up to 127 addressable devices can be connected to a loop circuit, devices like sensors, call point and interface units
- Two master alarm circuits
- RS485 Port to connect to repeat indicator panel(s)
- RS232 Port to connect to an external printer
- USB Port to connect to a Commissioning computer
- Fire Output - One set of clean voltage-free change over contacts
- Fault Output - One set of clean voltage-free change over contacts
- Class Change input that actions class change signal to selected sectors
- Evacuate input that actions all alarm sounders including master alarms and fire output
- Standby supply to power the system via batteries for 24 hours plus 0.5 hour alarm load
- Alphanumeric LCD with back light to display event information
- Integral 16 zone LEDs (with First fire zone LED flashing)
- LED lights for event indications
- Local audible buzzer for event announcement
- Push buttons for essential controls and menu driven commands.



042bc/01  
042bc/02  
042bc/03

The Nano panel is designed to meet the requirements of EN54-2 : 1997 and EN54-4 :1997. The panel can accommodate a loop circuit of analogue addressable devices, like fire sensors, sounders, manual call points and interface units. The panel gives local visual and audible indications of system events by means of indicators, a message display and an integral sounder. An integral mains derived supply provides power to the panel and the loop circuit in normal conditions and the integral batteries

provides a standby supply for up to 24 hours with 0.5hours of alarms should the mains supply fail. The controls are PIN code protected. The panel is designed for surface and semi flush mounting and facilitates both rear and top cable entry points.

**Technical data**

**Control panel**

Standard	Designed to EN54-2 : 1997
Approval	LPCB approved
Panel dimensions in mm	height 419 x width 347 x depth 85.5
Panel weight	approximately 3.12Kg without batteries 8.2Kg with batteries  2 - 12V 7Ah batteries are required (each battery weighing 2.54Kg [5.6lbs])
Storage temperature	-10°C to +55°C
Operating temperature	-5°C to +40°C
Relative Humidity (Non condensing) Temperature +5°C to +45°C	up to 93%
Emission	BS EN 61000-6-3:2001 Residential, Commercial & Light Industry <b>Class B limits</b>
Immunity	BS EN 50130-4: 1996 Alarm systems: <i>Electromagnetic compatibility</i> Product family standard: <i>Immunity requirements for components of fire, intruder and social alarm systems</i>
Ingress Protection	IP30
Colour	Door: Silver and Black Backbox: Black
Devices per loop	A maximum of up to 127 addressable devices on the loop
Device labels	Each device can be given a 32 character label for loop device location
Relays	Voltage-free contacts rated 1A @ 24Vdc
Fire	1 - set of change over contacts that are configured to operate immediately on a Fire event. The relay is normally de-energised
Fault	1 - set of change over contacts configured to operate immediately on occurrence of a Fault event. The relay is normally energised

Master alarm circuits and fuses	2 - Master alarm circuits operating at 24 volt nominal, 200 mA maximum per circuit MA1 - Fuse FS2 250mA AS MA2 - Fuse FS3 250mA AS Both fuses are Ceramic type 20mm x 5mm in size and are located on the MCB
Evacuate Input	A closed input will trigger all alarms to sound evacuate signal to include master alarms and activation of fire output
Class Change input	A closed input will trigger all configured sectors to sound the class change signal.
RS485 Port	RS485 - (PP3) Repeat indicator panel
RS232 Port	RS232 - (PP10) Printer
USB Port	USB - (P2) Commissioning tool
24V supply	Maximum output current of 200mA is protected by a Ceramic Fuse FS1 0.25A AS 20mm x 5mm in size, located on the MCB. Power taken from this supply will affect the battery standby duration.
Indicators	Fire (red) Power (green) Fault 'Common' (amber) 16 - Zones (red) Verify (amber) Disablement (amber) System fault (amber) Power fault (amber) Sounder Fault (amber) Test (amber) Delay (amber) Sounder Disablement (amber)
Display	Alpha-numeric display - 8 lines by 40 characters per line, back-lit, (LCD having black characters on green background)
Internal sounder	Audible announcement of Fire and Fault events.
Controls at Access level 1	Menu navigation buttons to view events and for PIN code entry to other access levels.

## Installation instructions

<p>Controls at Access level 2 (Customer mode)</p>	<p>As for controls at Access level 1 plus controls for:</p> <ul style="list-style-type: none"> <li><input type="checkbox"/> Cancel buzzer</li> <li><input type="checkbox"/> Emergency controls</li> <li><input type="checkbox"/> Clock set</li> <li><input type="checkbox"/> Day/Night mode</li> <li><input type="checkbox"/> Enablement/Disablement</li> <li><input type="checkbox"/> Weekly test</li> <li><input type="checkbox"/> Zone test mode</li> <li><input type="checkbox"/> Display test</li> <li><input type="checkbox"/> Loop status/repair</li> <li><input type="checkbox"/> Firmware version</li> <li><input type="checkbox"/> Site data</li> </ul>	<p><b>Power supply</b></p>	<p>Standard</p>	<p>Designed to EN54-4 : 1997</p>	
<p>Controls at Access level 3 (Engineer mode)</p>	<p>As for controls at Access level 2 plus controls for:</p> <ul style="list-style-type: none"> <li><input type="checkbox"/> Delay settings</li> <li><input type="checkbox"/> Calendar settings</li> <li><input type="checkbox"/> External inputs</li> <li><input type="checkbox"/> Serial ports</li> <li><input type="checkbox"/> Weekly test settings</li> <li><input type="checkbox"/> Zone label and linkage</li> <li><input type="checkbox"/> Device settings</li> <li><input type="checkbox"/> Interface channel settings</li> <li><input type="checkbox"/> Sound Signal settings</li> <li><input type="checkbox"/> Zone Cause and Effect</li> <li><input type="checkbox"/> Sound alarm mode &amp; operation</li> <li><input type="checkbox"/> Signal settings</li> <li><input type="checkbox"/> Loop status and map</li> <li><input type="checkbox"/> Site data backup &amp; restore</li> </ul>	<p>Mains supply voltage and fuses</p>	<p>230Vac -15% +10% 50Hz/60Hz protected by: FS3 Fuse - 3.15A (T) 250V Ceramic 20mm x 5mm, located on PSU. Input current - 0.45A</p>	<p>Nominal supply voltage for master alarm circuits</p>	<p>24V +/- 4V</p>
<p>Controls at Access level 4 (Maintenance mode)</p>	<p>As for controls at Access level 3 plus controls for:</p> <ul style="list-style-type: none"> <li><input type="checkbox"/> Clear logs</li> <li><input type="checkbox"/> Maintenance reminder</li> <li><input type="checkbox"/> Firmware upgrade</li> <li><input type="checkbox"/> Device time averages</li> <li><input type="checkbox"/> Device condition codes</li> <li><input type="checkbox"/> Diagnostics</li> <li><input type="checkbox"/> Reset codes, configuration and labels to factory default settings</li> <li><input type="checkbox"/> Backup &amp; restore changes</li> <li><input type="checkbox"/> Fast find</li> <li><input type="checkbox"/> Loop power up/down</li> <li><input type="checkbox"/> Start detection</li> <li><input type="checkbox"/> Commissioning mode</li> <li><input type="checkbox"/> Beam alignment</li> <li><input type="checkbox"/> Proprietary Logo</li> </ul>	<p>Lithium Battery</p>	<p>BATT3 on MCB. Type Panasonic CR2032 3V cell. <b>CAUTION: Replacement battery must be the same or equivalent type battery. Dispose of used batteries according to the manufacturer's instructions.</b></p>	<p>Battery circuit 'BAT1' and fuse</p>	<p>FS1 Fuse 3.15A (T) TE5 on PSU</p>
		<p>PSU volts &amp; fuses 43V (quiescent) 24V</p>	<p>FS6 Fuse 1.0A (T) TE5 on PSU FS4 Fuse 1.0A TE5 on PSU</p>	<p>Battery</p>	<p>Powersonic PS-1270F1-FR 2- 12V 7Ah sealed lead acid batteries that will provide 24 hours standby and 30 minutes alarms, determined by system loading via SentiOne tool.</p>
		<p>Storage temperature</p>	<p>-10 to +55°C</p>		
		<p>Operating temperature</p>	<p>-5°C to +40°C</p>		
		<p>Relative Humidity (Non condensing)</p>	<p>up to 93% (Temperature +5 to +45°C)</p>		
		<p>Maximum current from battery without mains connected</p>	<p>1.5A</p>		
		<p>EN54 Part 4 data</p>	<p>I max a</p>	<p>240 mA</p>	
			<p>I max b</p>	<p>1.0 A</p>	
			<p>I min</p>	<p>300 mA</p>	
			<p>UVLO</p>	<p>20.7 V 400mV</p>	
			<p>Ri max</p>	<p>1.5</p>	















**Always use the recommended replacement or equivalent type battery, as there is a risk of an explosion if incorrect battery is used.**



**After power down hazardous voltages may still be present even if indications are extinguished.**

# Panel installation

The Nano panel is supplied fully assembled, it is important to check the contents to ensure all the parts are supplied. Note the 2 x 12V 7Ah batteries are supplied in a separate pack.

Parts in the Spares packages		Quantity
Fuse T3.15A H 250V 20mm x 5mm Ceramic		1
Fuse T250mA H 250V 20mm x 5mm Ceramic		3
Fuse T1A TE5		2
Fuse 3,15A TE5		1
10K Ohms Resistor		4
Battery Link		1
Battery Lead		1
Allen Key#		1
Screw cover		1
Panasonic CR2032 3V cell		1
Trimmer tool		1
Document pack : Operating, Installation, Quick reference + template and Log book		1

# - part supplied in a plastic bag fitted to the enclosure.

## How to disassemble the panel to gain access to the Backbox

- Pull out the 'screw cover' ① which may be supplied fitted to the Outer Cover, the 'screw cover' is held in place by magnets.
- Open the two captive screws ② on the 'Outer cover' using the allen key and unhook the 'outer cover' ③ from the 'backbox'.
- Open the two captive screws ④ on the 'electronic module' and lift out the module ⑤ from the 'backbox'.

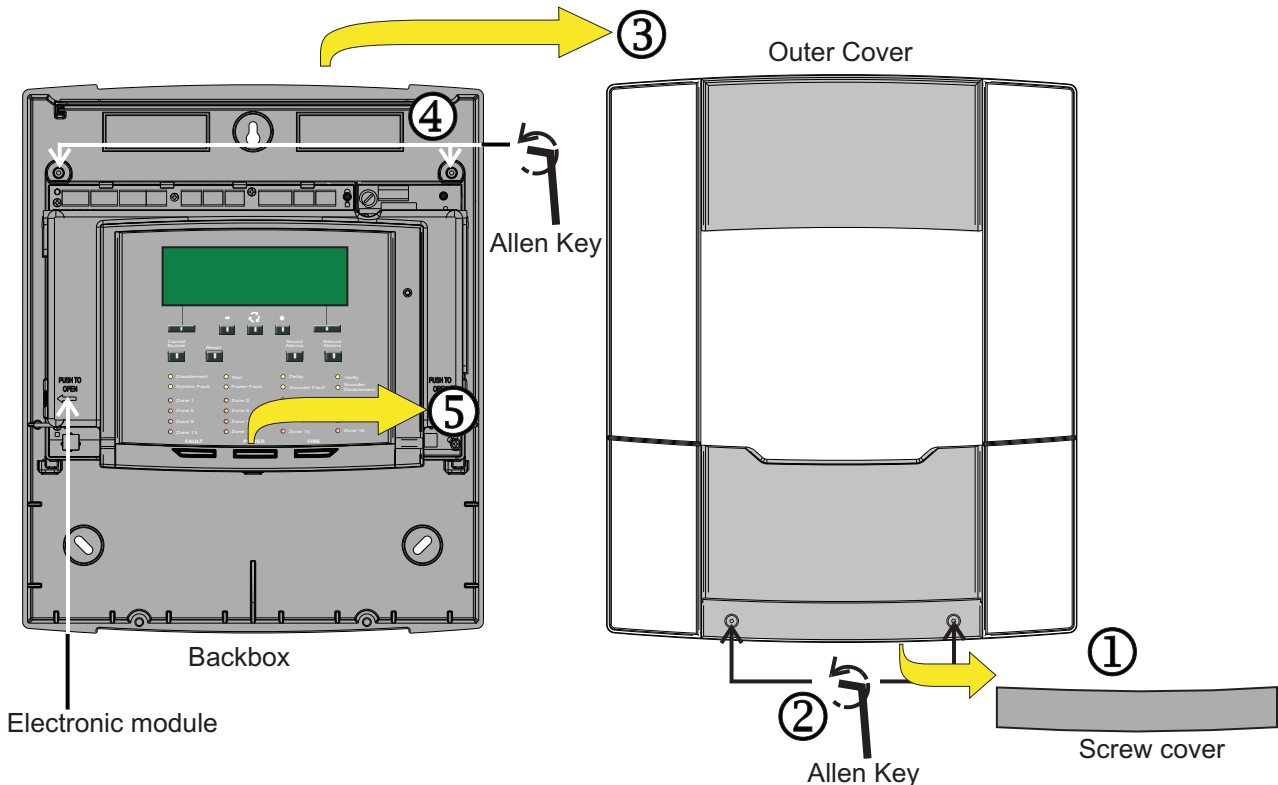

# Installation instructions

## How to mount the backbox and use of dedicated cable entry points



**Unused knockouts that have been removed should not be left open.**

Knockout the required dedicated cable entry points from the back box. Use the correct method of knocking out the entry points, as illustrated below. Use the three fixing points to mount the backbox onto a flat wall surface using suitable fixings.

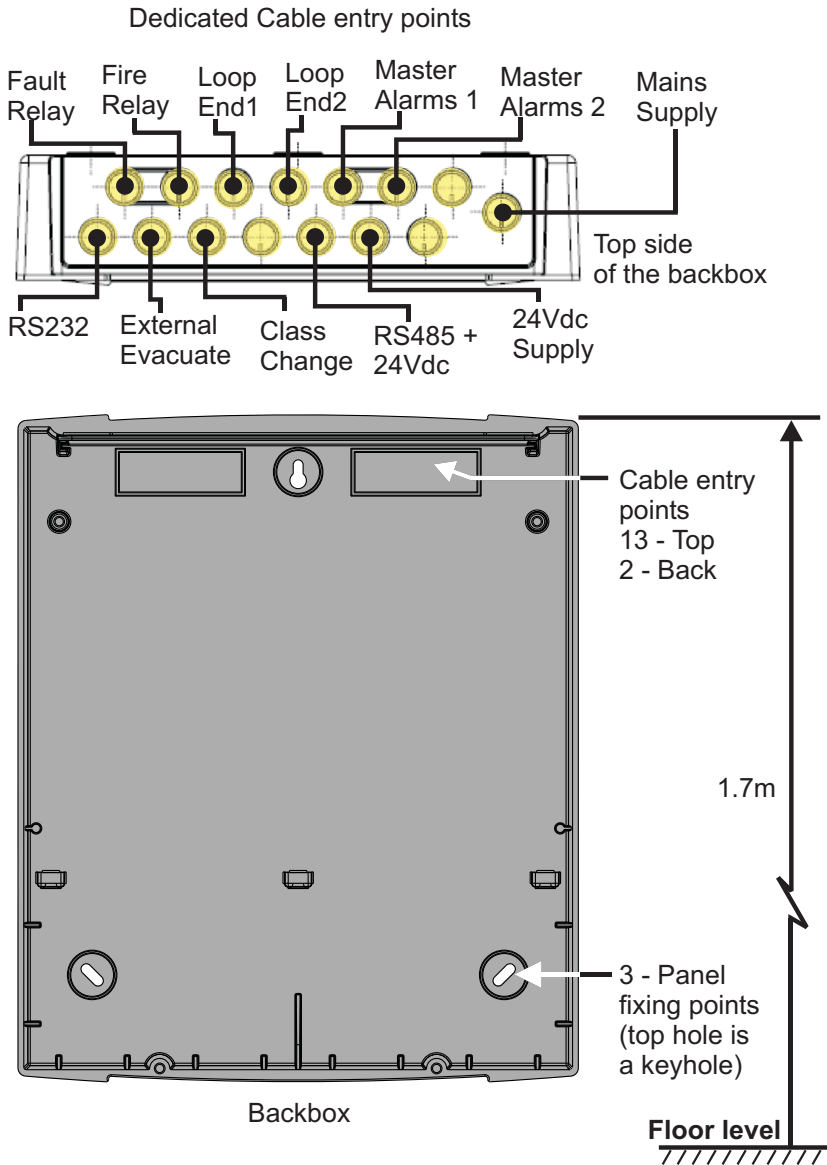

### How to knock out cable entry points

15° - 20° maximum

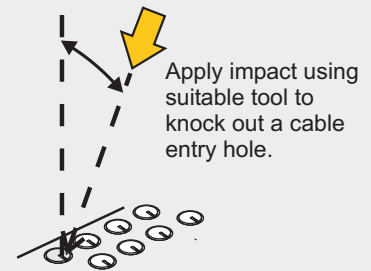

## Flush Mounting the backbox

The control panel may be flush mounted using a flush surround NANO-FLUSH.

- Cut out an aperture in the wall to allow the flush surround to be fitted, see diagram for dimension of the aperture.
- Using the fixing holes on the flush surround, secure it into the aperture side walls.
- Route the cables through the cable entry points into the panel and at the same time insert the panel into the flush surround.
- Fit the panel back box to the flush surround using the 3-off 5mm screws not supplied with the flush surround.

Aperture depth should not be less than: 75mm

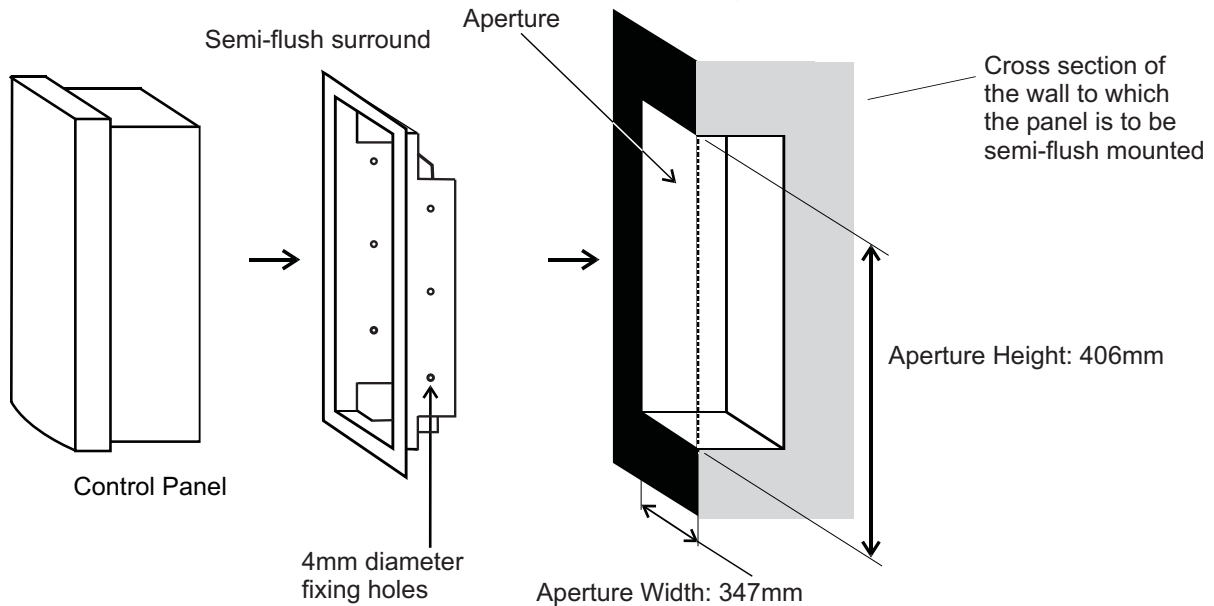

## Refitting the electronics module

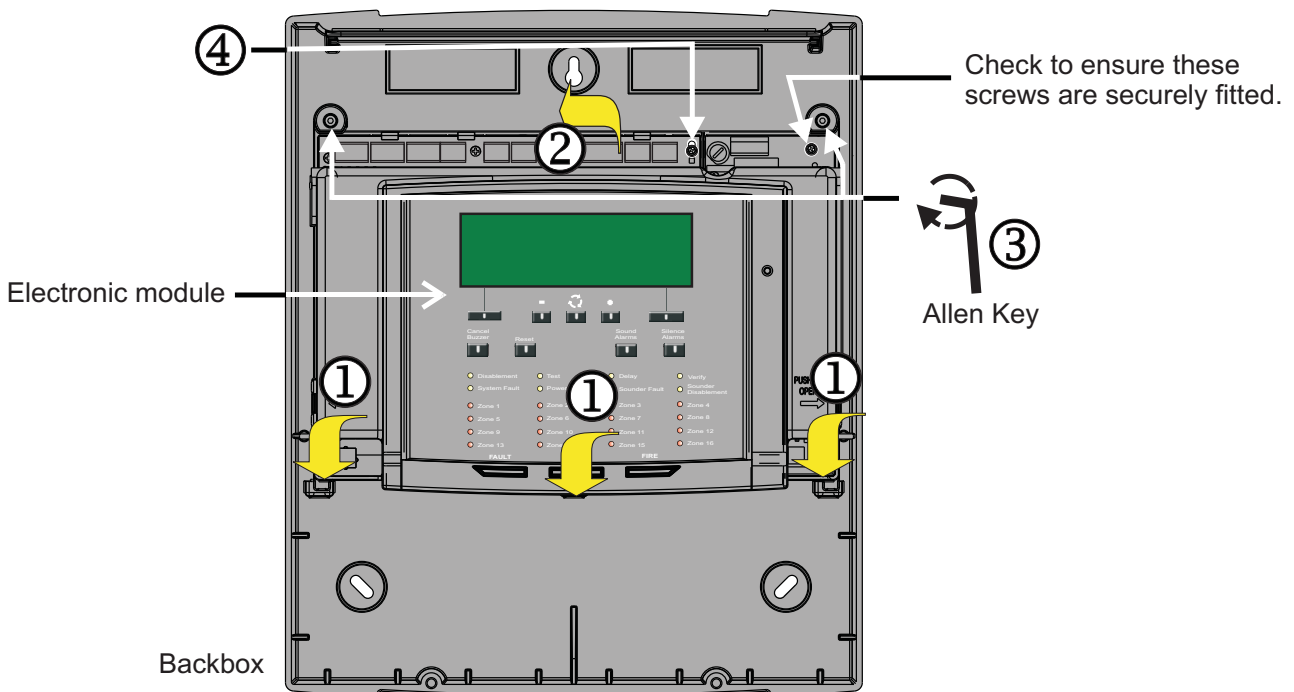

Locate the three tabs of the electronic module ① into the backbox and close the upper part ② of the module into the backbox and then secure the assembly by tightening the two captive screws ③ using the allen key. Ensure the two PCB fixing-screws ④ that provides earth bonding are securely fitted and are not loose.

## Installation instructions

### Cable termination on enclosure

The wire length between the cable termination and point of connection must be as short as possible. Cable earth drain wire, where applicable, must be connected to the respective drain termination point.

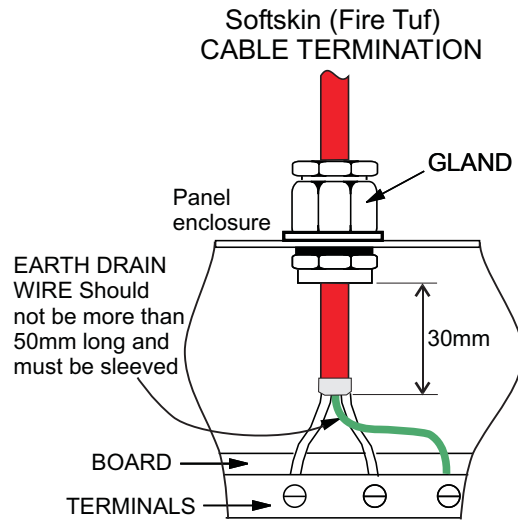
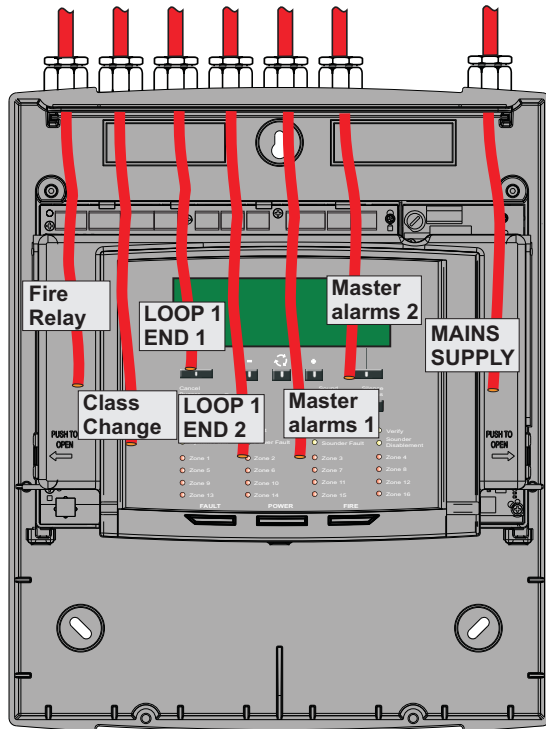

**Cables that are not required to be connected to terminals must be neatly coiled up and carefully tucked away into the backbox in the space above the electronic module.**

Terminate each cable at the dedicated entry point on the enclosure, using the cable manufacturers recommended techniques.

Where the cable is not required to be connected, leave **300mm** (unless otherwise specified) tail wire length and mark each **core** identifying its final point of connection. Where the cable is required to be connected, ensure it is securely fitted to the respective terminal.

### Wiring test



**DO NOT undertake high voltage insulation tests WITH THE CABLES CONNECTED to the panel and system device terminals. Such a test may damage the electronics circuitry in loop devices and at the panel.**

## Mains supply



Ensure that the mains supply cable enters the panel through a dedicated cable entry, located adjacent to the mains terminal block and that is also segregated from loop wiring.



These fire alarm system products are not designed to be powered from IT Power systems.

All mains powered equipment must be earthed. The mains supply to any fire alarm control and indicating equipment must be via an unswitched 5A fused spur unit. A disconnect device must be provided to disconnect both poles and must have a minimum gap of 3mm. The **disconnect device** should be available as part of the building installation and must be easily accessible after installation is complete.

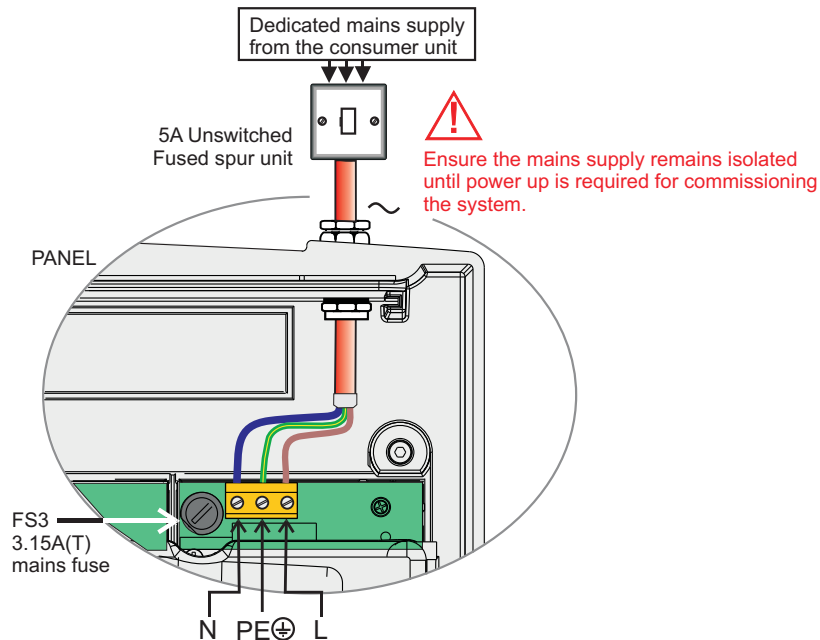

The fused spur isolator cover should be marked:

**FIRE ALARM - DO NOT SWITCH OFF**

The fire alarm equipment's fused spur unit must be fed from a dedicated switch or protective device at the local mains supply distribution board.

## Mains and battery supply connections

The mains and battery supply cables must be installed to a stage to **facilitate the power up** for commissioning, which is carried out by the Servicing organisation.



Where the mains cable is to remain disconnected, its tail ends must be insulated to prevent dangerous conditions arising in the event of accidental switching on of the mains supply.

## Removable terminal blocks

To ease installation the terminal blocks on the Main Control Board can be unplugged from the board.

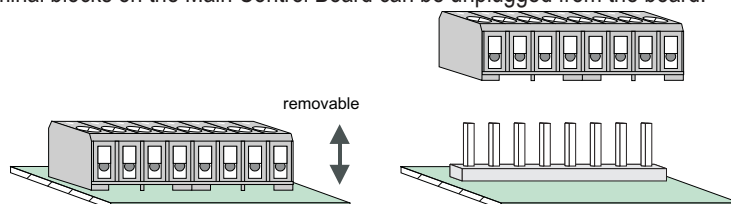

## Terminals for external circuits on Main Control Board

The Main Control Board (MCB) holds all the terminals for the connection of fire alarm loop circuit, master alarms, fire and fault relays, class change, evacuate input and repeat indicator panel.

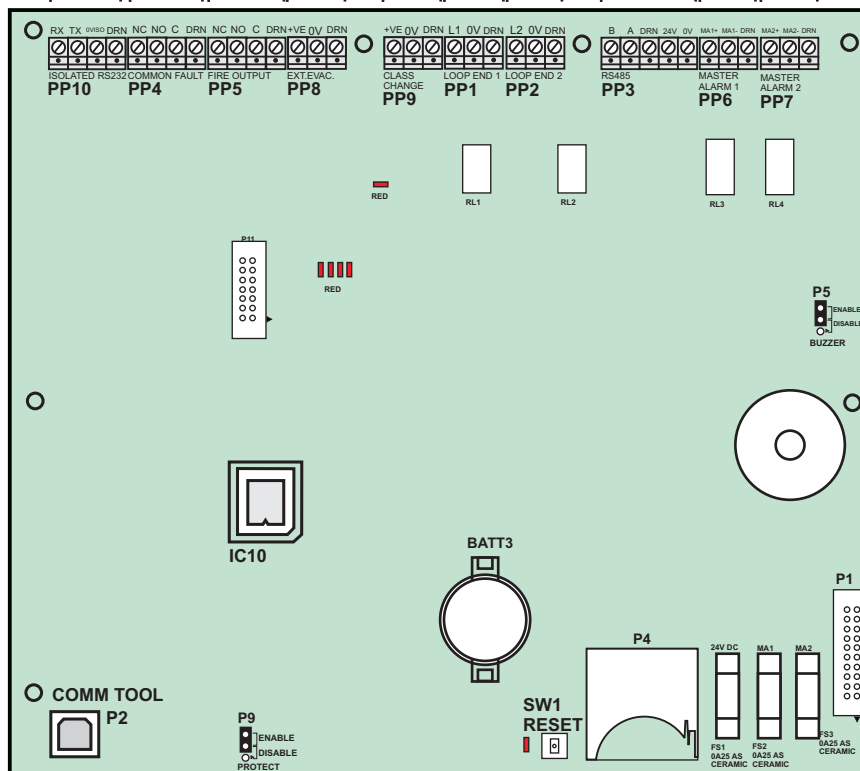
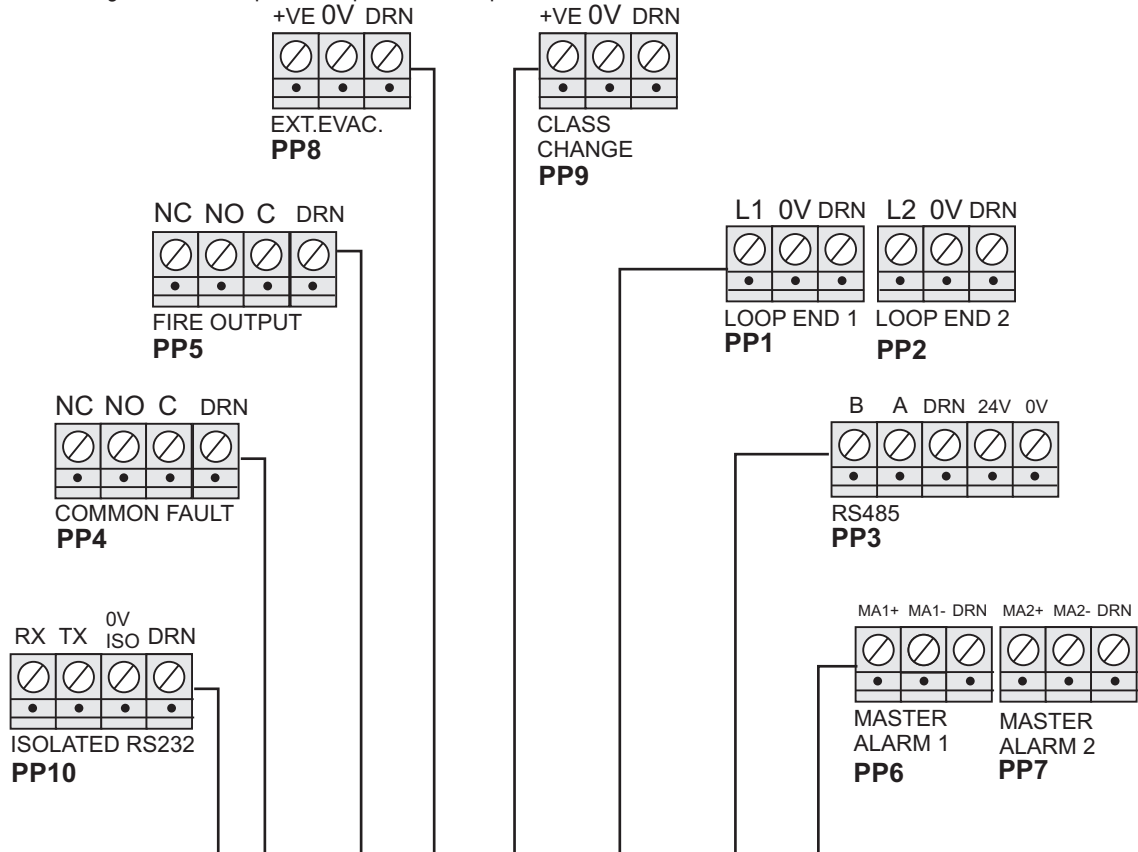

**Main Control Board**

## Device loop circuit

The device loop circuit can accept connection of addressable devices, up to 127 maximum. To maintain earth continuity on the loop, the **loop cable screen** must be continued through each system device, whether the earth is connected to a device or not.



The loop circuit must not cover more than 10,000m<sup>2</sup> of floor area of a protected site.

A spur circuit must always be taken from the "line common" terminals of a 3-way device.

A spur must not cover more than the equivalent of one zone as defined in BS5839 Part 1.

As every device has a loop isolator, the application of more than 32 devices does not require any special consideration.

Ensure the maximum cable length between loop devices does not exceed 250m. This is the cable distance between previous and next device on the loop.

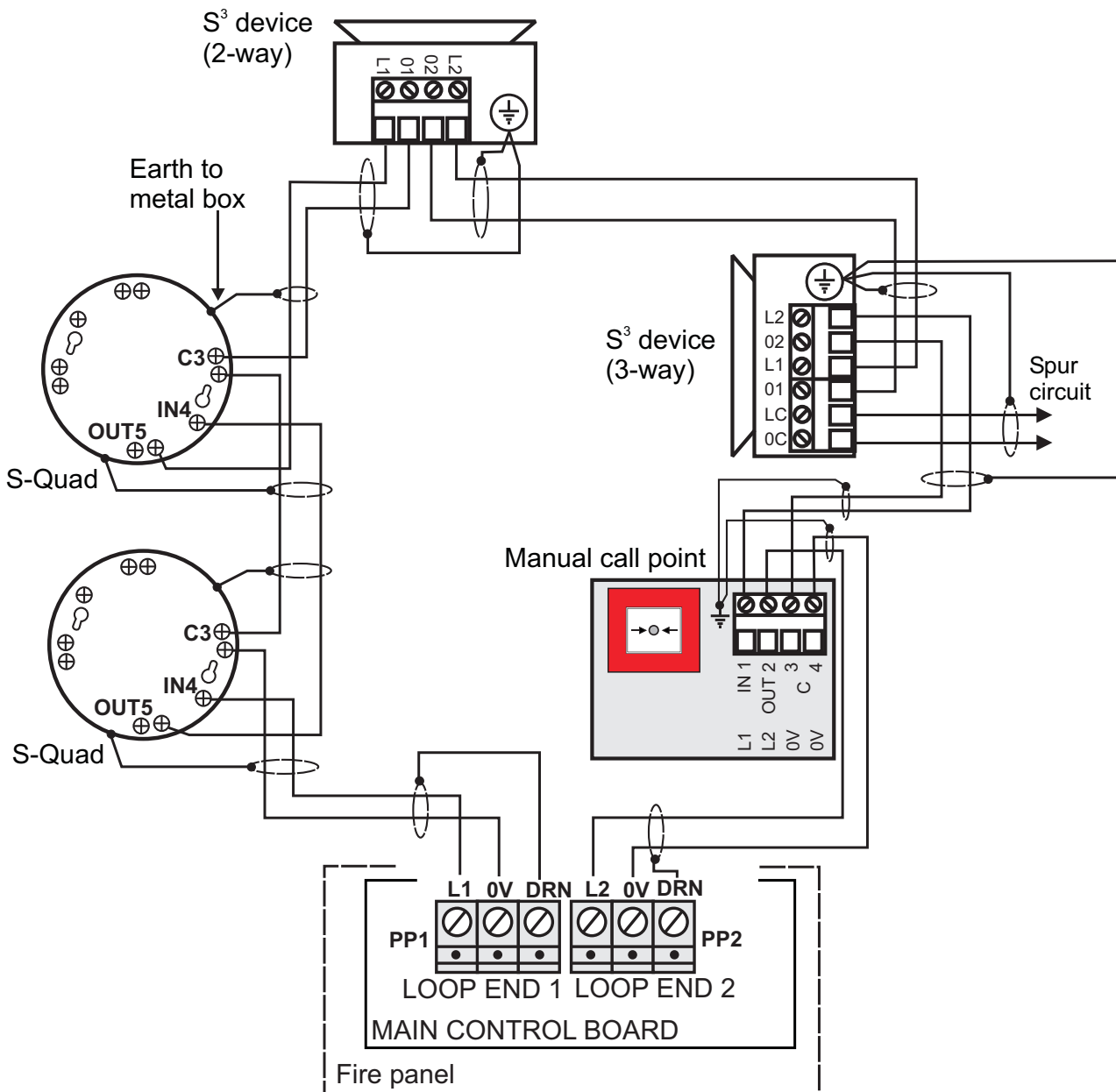

# Installation instructions

## Master alarm circuits

There are two MASTER ALARM circuits that can accept the connection of conventional alarm sounders including the conventional Speech-Sounder-Strobe S-Cubed products.

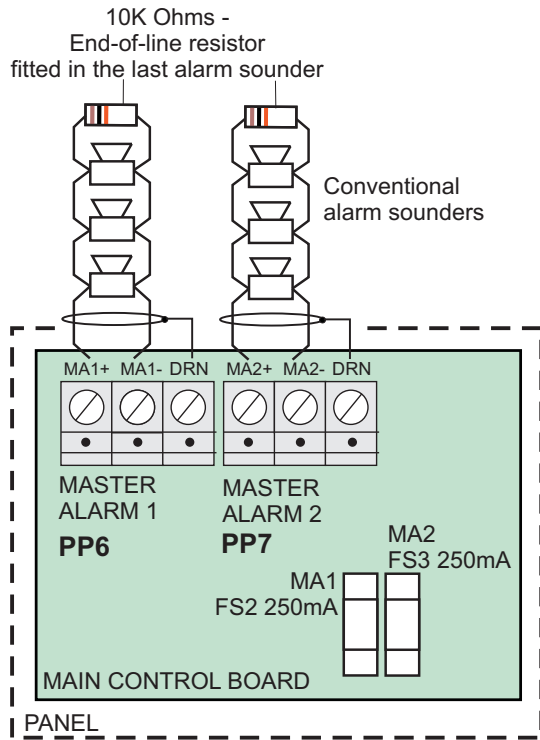

If master alarms are not being used then connect the 10K ohms End-of-line resistors to the master alarm terminals.

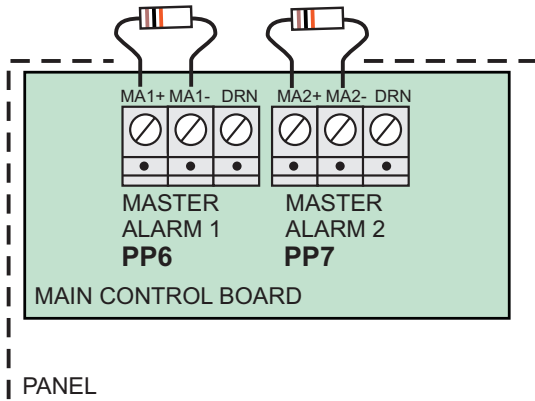

## Common Fault contacts

The control panel has a COMMON FAULT relay having voltage free contacts that can be used to signal external equipment. The relay is normally energised and will de-energise on occurrence of a fault event. The relay contacts return to their normal state when the panel has no fault present. The contacts should be powered from an independent power supply, where required.

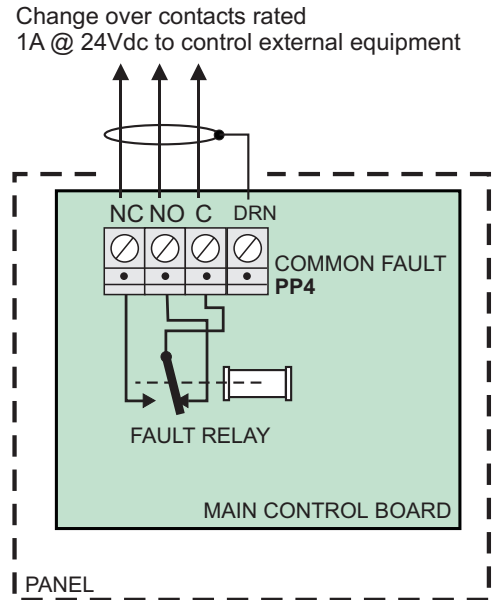

**i** The fault relay is shown in its normal state with panel powered up and with no active fault.

### Fire Output contacts

The control panel has a FIRE OUTPUT relay having voltage free contacts that can be used to switch plant equipment, such as lift control system. The relay is normally de-energised and will energise on occurrence of a fire event. The relay can be configured to operate with a zone immediately or after a delay. The relay will operate with 'External Evacuate' input and on operating the 'Sound Alarms' button if configured during commissioning. The relay operates in the event of a fire event. The contacts should be powered from an independent power supply, where required. The fire output can be used to signal external equipment that in turn signal Alarm Receiving Centre.

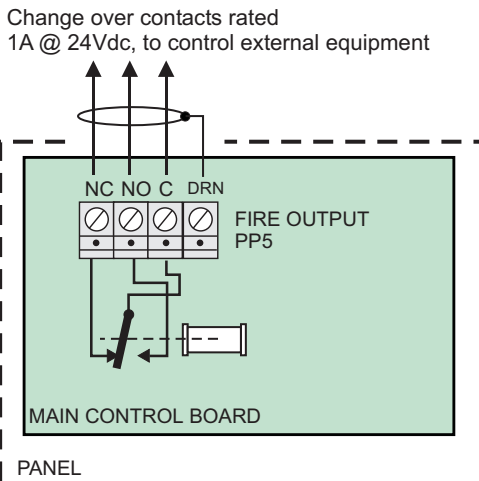

The relay is normally de-energised and operates with a fire event.

### Repeat indicator panel

Up to four REPEAT INDICATOR PANELS can be connected directly to the fire panel to its RS485 Port. The furthest repeat indicator panel can be installed a maximum of 1Km cable distance away from the fire panel. The factory default setting assumes there is no repeat indicator panel connected to the RS485 port, the fire panel must be configured during commissioning to know there is a repeat indicator panel installed in the system.



If there is only one repeat indicator panel connected then it is possible to use the 24V supply on the Main control board.

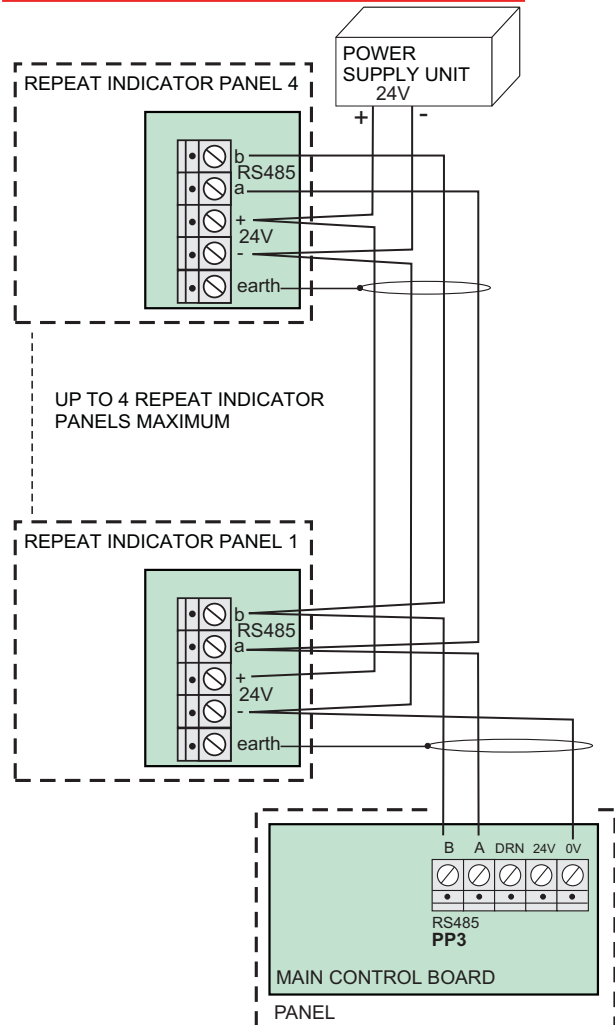

# Installation instructions

## External Evacuation input

The EVACUATION INPUT function is activated on operation of an external switch wired in the manner shown below. The switch can be installed a maximum of up to 100m cable distance away from the fire panel. The wiring is monitored for both open and short circuit faults. If this function is used, it will sound site wide evacuate signal to all the sector alarms and master alarms, plus activate fire output.

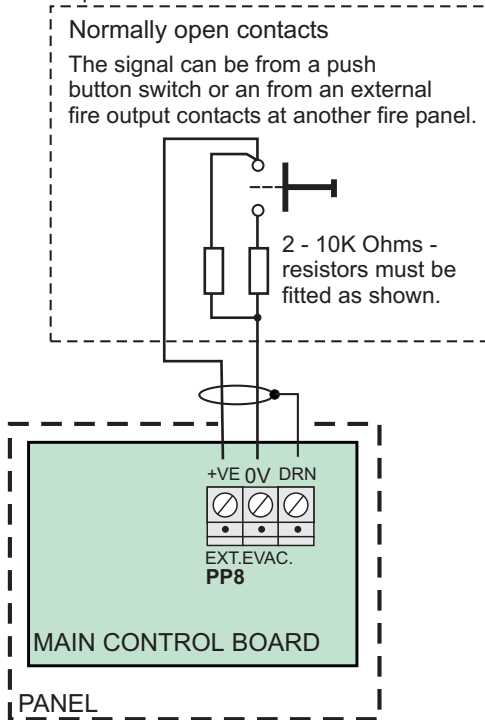

## Class Change input

The CLASS CHANGE function, if configured, will sound class change signal to the respective sectors when the external switch is operated. The switch can be installed a maximum of up to 100m cable distance away from the fire panel. The input wiring is monitored for both open and short circuit faults.

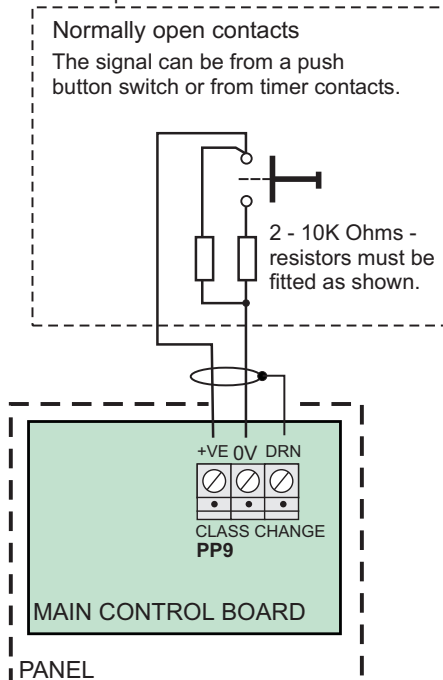

## RS232 Port

The RS232 port of the fire panel can be configured to allow connection of external printer.

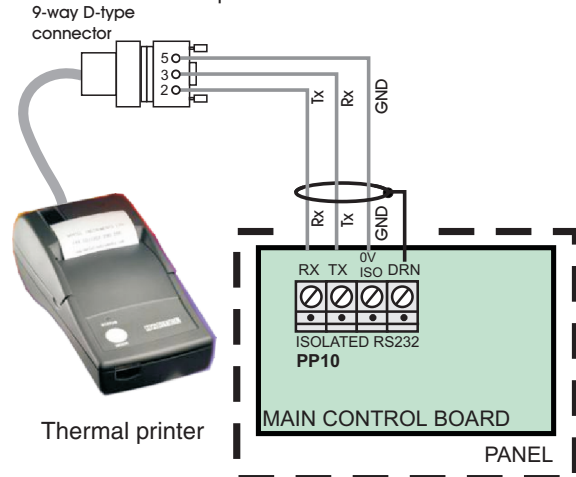

The panel's RS-232 port is set at 9600 baud.

## USB Port

The USB port is used to connect to the commissioning tool for ease of configuring the system.

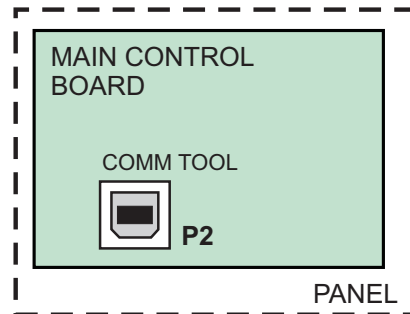

## Battery installation

The batteries are fitted inside the backbox and connected up in the manner shown, however the final connection to power up the panel is made during system commissioning, which is done by the servicing organisation.

To fit the batteries inside the panel enclosure:

- Open out the two tabs on the electronic module at positions ① and lift open the 'LCD assembly' to an angle 45° maximum ②, use a non conductive prop ③, such as a plastic pen, to keep the 'LCD assembly' open.
- Connect the batteries in the manner illustrated ④ ensuring one of the + connection is left disconnected. Then fit the batteries inside the enclosure as illustrated ⑤.
- Fit the connector of the battery lead ⑥ to socket P7 on the Power supply unit.
- Remove the prop and close the LCD assembly.

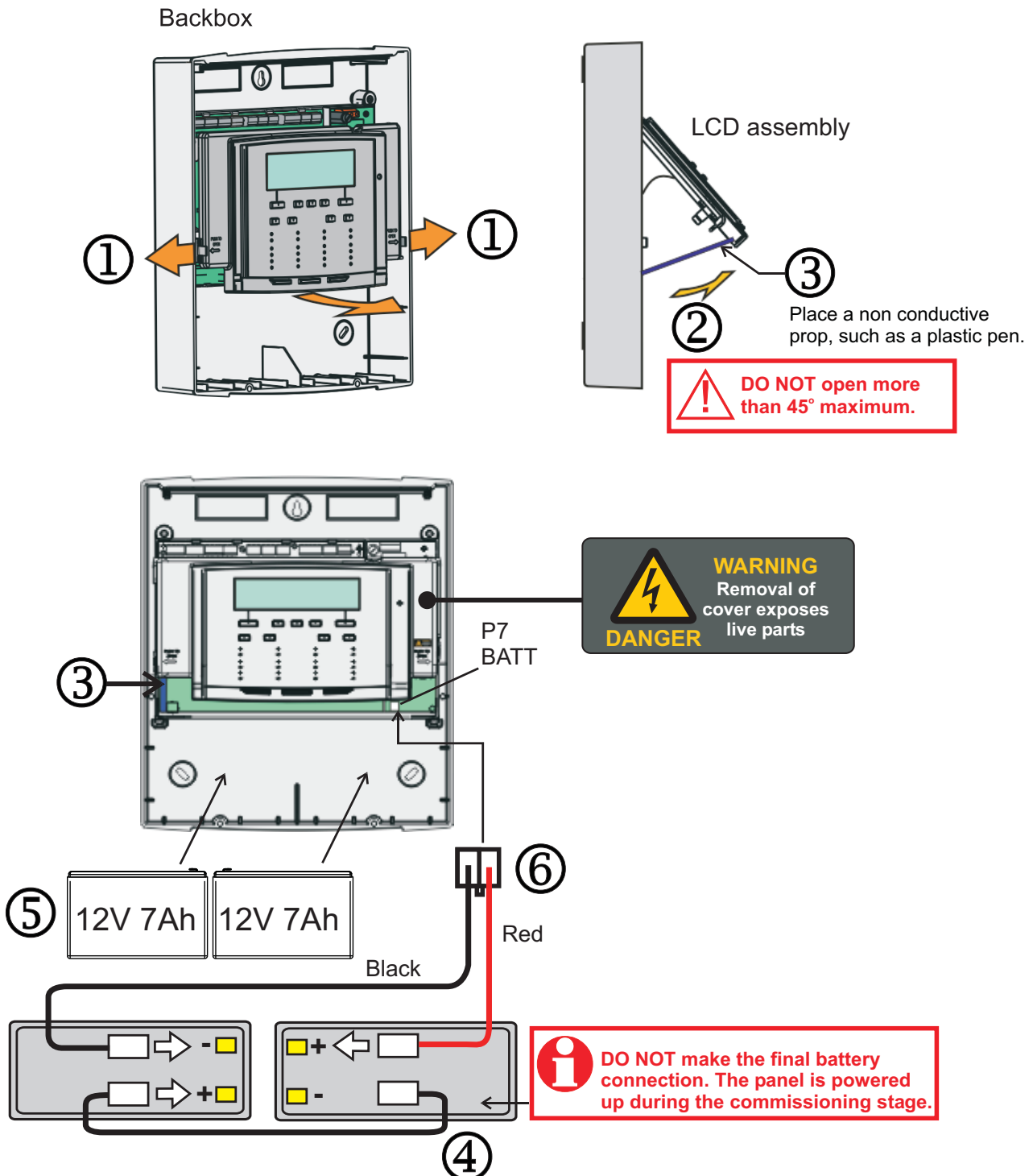

## Installation instructions

### On completion of panel installation

On completion of all cable installation ensure the wires are neatly stored in the space above the electronics module.

Fit the 'outer cover' by hooking it over the top edge ① of the 'backbox' and then close the bottom of the 'outer cover' ② onto the 'backbox' and secure the cover by the captive screws ③ using the allen key. Fit the 'screw cover plate' ④ which is held in place magnetically.

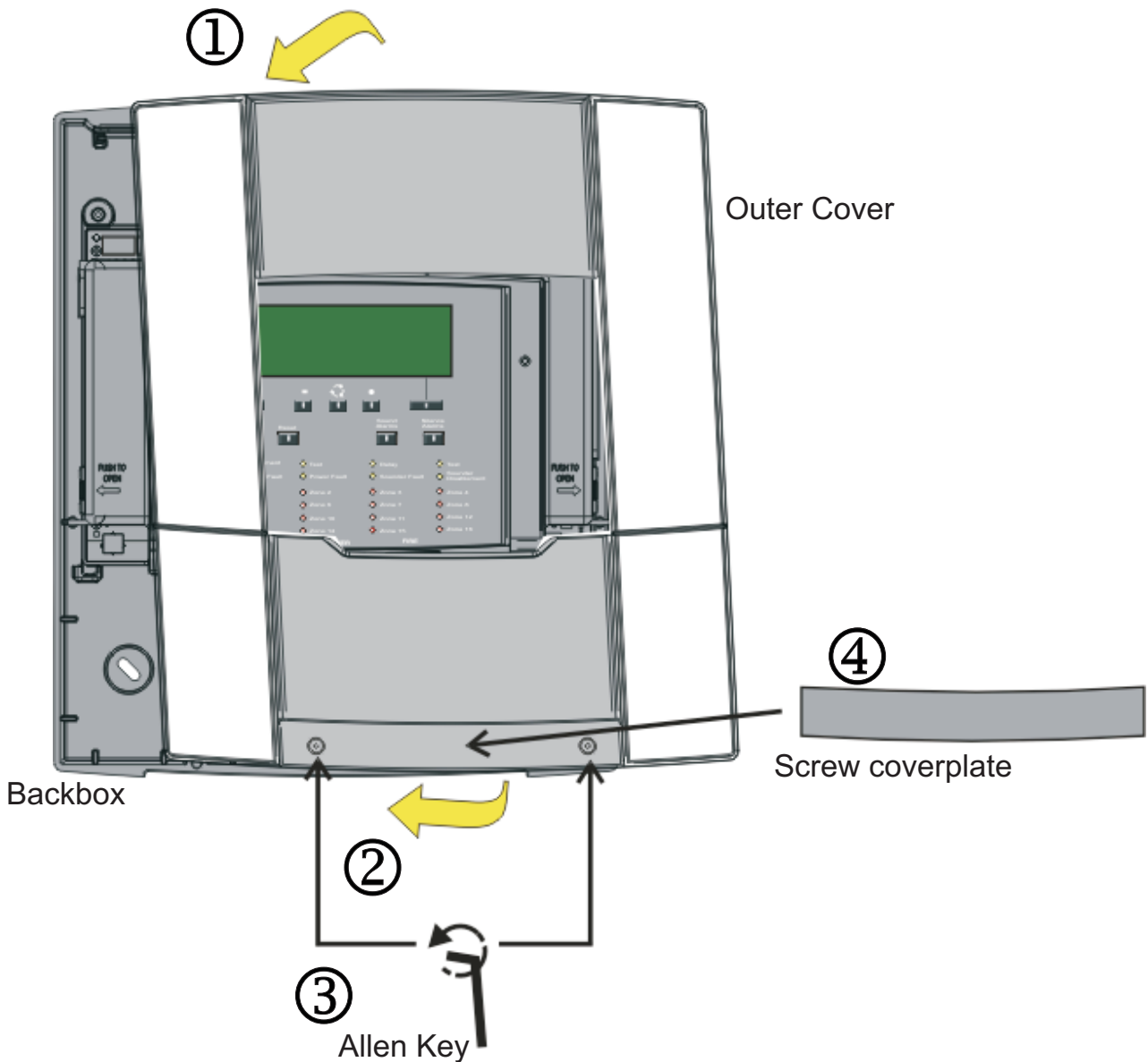

**All the remaining parts must be kept in a safe and secure place for the servicing organisation to fit during commissioning of the system.**

---

# Nano panel parts

This section lists all the parts that can be used in a nano system. For further details on the availability of the parts, contact your supplier.

## **Control Panel**

NANO-24	Nano Control panel c/w 2-12V 7Ah batteries for 24hr standby - supplied
NANO-FLUSH	Flush Surround for the Nano Control panel

## **Printer**



PRINTER-HAND	Handheld serial thermal printer
PRINTER-H-PAPER	Thermal paper for the handheld printer





	<p><b>WEEE Directive:</b>                  At the end of their useful life, the packaging, product and batteries should be disposed of via a suitable recycling centre.                  Do not dispose of with your normal household waste. Do not burn.</p>
---	---

	<p><b>At the end of their useful life, the packaging, product and batteries should be disposed of via a suitable recycling centre and in accordance with national or local legislation.</b></p>
---	---

 0832	 2831
Manufactured by: Honeywell Life Safety Systems-Romania Street: Str. Salcamilor 2 bis- Lugoj  2831-CPR-F4210 <b>NANO-24</b>	
<p><b>EN54-2: 1997, A1:2006</b>                  Control and Indicating equipment for fire detection and fire alarm systems in buildings.                  7.8 Output to fire alarm devices                  7.11 Delays to action outputs                  8.3 Fault signals from point                  10 Test condition</p> <p><b>EN54-4: 1997, A1:2002, A2:2006</b>                  Power supply equipment for fire detection and fire alarm systems in buildings.</p>	

Honeywell Gent reserves the right to revise this publication from time to time and make changes to the content hereof without obligation to notify any person of such revisions of changes.

	Honeywell Building Technologies, Building 5 Carlton Park, King Edward Avenue, Narborough, Leicester, LE19 0AL		Website: <a href="http://www.gent.co.uk">www.gent.co.uk</a>
	Telephone +44 (0) 203 409 1779	Tech. Support: <a href="http://www.gentexpert.co.uk">www.gentexpert.co.uk</a>	