

Mains Powered Interface (78302-02NM)



The SenTRI Mains powered interface unit (Part number 78302-02NM) is EN54-4 compliant with battery backed power supplies that can be directly connected to a loop of a SENTRI2 and SENTRI4 panel and also has highly flexible interfacing capability. The unit can be connected to the loop of a SENTRI1 panel with reduced capability. The 4 channels can be individually configured to provide Output and Input interface in various configuration modes, to control external equipment and receive input to allow the fire system to make decisions and take actions. It is possible to have combined inputs and outputs giving a total of 8 external circuits connected (e.g. 4 sector outputs and 4 confirmation inputs). This unit have room to accommodate optional modules on to DIN rails. It has a configurable auxiliary power output that is derived from its self contained mains power supply unit, which is battery backed to continue to deliver power in the event of mains supply failure.

Symbols on product

	Electric shock hazard.
	Protective Earth connection terminal.
	The WEEE symbol. It indicates the product is to be recycled and not thrown away.
	The CE compliance logo. This product is in conformity with the relevant European Union harmonisation legislation.
	The RoHS compliance logo. The RoHS directive restricts the use of certain hazardous substances commonly used in electronic and electronic equipment.

Technical Data

Standards - designed to meet	EN54:part 4:1998 EN54:part 17:2005 EN54:part 18:2005			
Overall dimensions	478mm x 322mm x 145mm			
Assembled weight (approx.)	5.25Kg (excluding batteries and optional components fitted)			
Enclosure	Steel			
Colour	RAL7024 Graphite Grey (fine textured)			
Storage temperature	-20°C to +70°C			
Ambient operating temperature	-10°C to +45°C			
Relative Humidity (Non condensing)	up to 95% Temperature +5°C to +45°C			
Ingress Protection	IP31(estimated)			
Mains voltage	230V -15% +10% 50Hz/60Hz			
Rated current	0.7A			
Input modes	Input can be fault monitored, voltage free contacts or conventional detection zone. Refer to the commissioning information for more details.			
Zone Nominal voltage	16V or 22.5V (default) ±15%			
Quiescent current	20mA per zone (default) Zone short circuit current limited to < 30mA EN54 compliance limitation: 32 devices OR Maximum of 20 diode bases per zone			
Output modes	Outputs are monitored 24V (nominal) 0.5A or LED drive. Refer to the commissioning information for details.			
Confirmation modes	It is possible to configure all Inputs and Outputs as confirmation channels.			
Batteries	2 x 12V 2.1Ahr (1Kg each)			
Compatibility	SENTRI2/4 :MCC ≥ V4.43 :LPC ≥ V4.41 SENTRI Commissioning tool ≥ V1.27 SENTRI1 :MC ≥ V2.50 SENTRI1 Commissioning tool ≥ 2.x			
Operating Voltage	35V - 48V			
EN54-4 : 1997 data	I_{maxa}	I_{maxb}	$R_i \max$	
	1.5A	1.5A	2.5R	
	I_{min}	80 µA		
	UVLo	18.5Vdc ±5%		
$V_{batt \min}$ (with no mains)	22.5Vdc ±5%			
EN54-17 : 2005 (section 4.8) data:	V_{max}	48V	$I_C \max$	0.8A
	V_{nom}	40V	$I_S \max$	1.25A
	V_{min}	24V	$I_L \max$	50µA
	VSO max	16V	ZC max	0.2Ω
	VSO min	8V		
EN54-18 : 2005 data	V_{max}	42V		
	V_{min}	24V		

Sector and Auxiliary Outputs	<p>Sector outputs: 0.5A max. each at 24V ± 3V, electronically current limited to approximately 1A at 25°C</p> <p>Auxiliary power output: 0.5A max. at 24V ± 3V, electronically current limited to approximately 1A at 25°C</p> <p>Max. total output current: 1.5A</p>
Terminals	Terminals for spur circuit off main loop
Emission	BS EN 61000-6-3:2007 A1:2011 EMC for residential, commercial & light Industry.
Immunity	BS EN50130-4:2011 for alarm systems
Terminals	2.5mm ²

Features

Fail-safe operation

A fail-safe operation is available on all Sector outputs, if loop communications are lost for a defined duration then the Sector outputs will be turned ON. Sector outputs will turn OFF immediately when communication is restored.

Synchronisation

Adjustable synchronisation pulses can be selected for all sector outputs to synchronise the operation of devices such as xenon strobes or speech sounders.







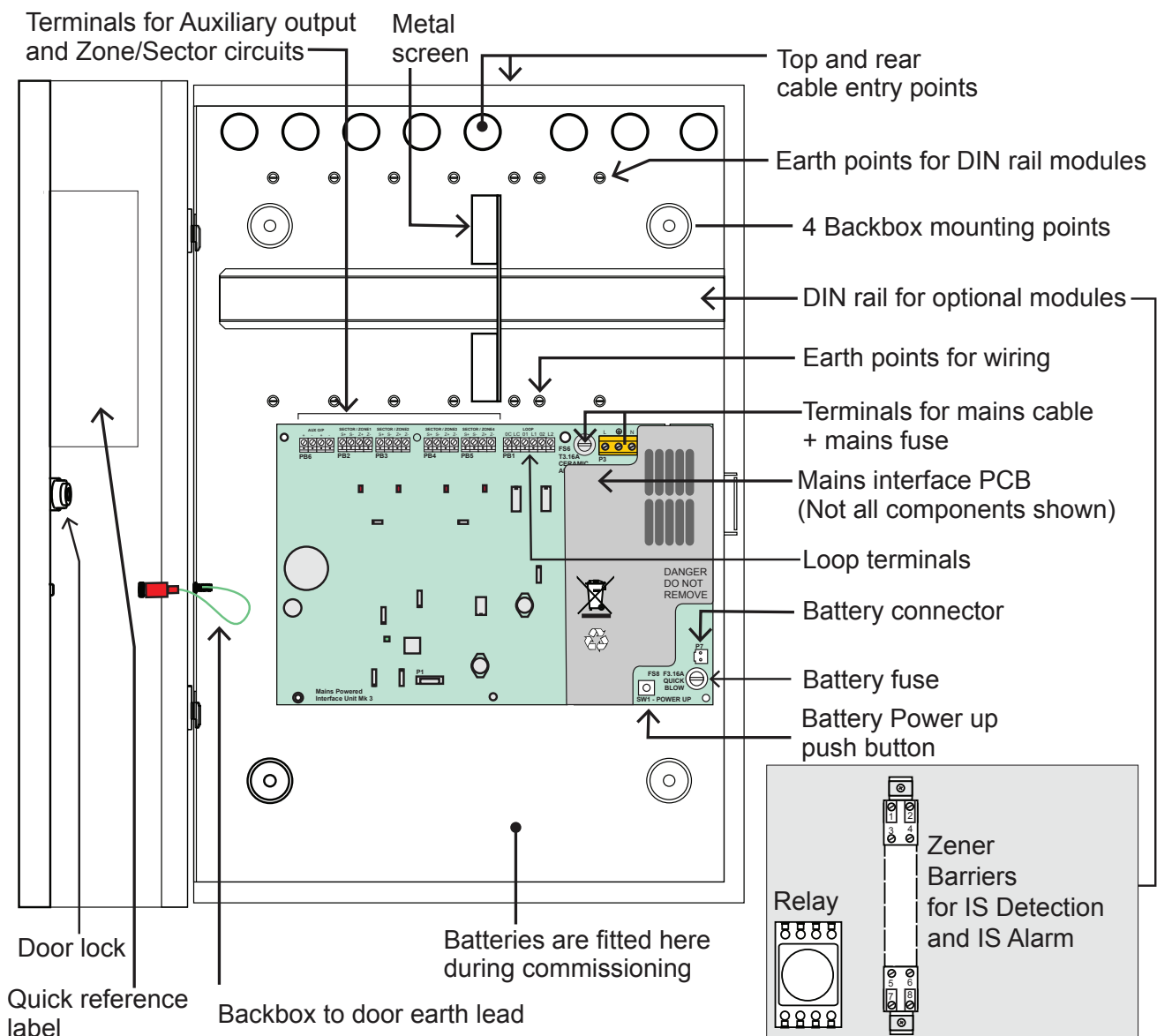

Auxiliary Output

The Auxiliary output can be programmed to automatically turn OFF when a mains failure occurs to preserve battery capacity. The output can also be programmed to provide a reset pulse when a fire reset occurs, (this requires other line(s) on the interface to be programmed as inputs).

 **Repetitive switching of capacitive loads greater than 1500uF is not possible and will result in the thermal protection circuit automatically reducing the output voltage.**

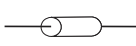
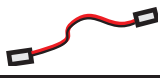

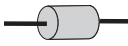
Installation

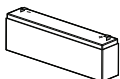
	Spare Parts	Qty
	Fuse 3.15A AS Ceramic (20mm x 5mm)	1
	Fuse 3.15A QB Glass (20mm x 5mm)	1
	Resistor 3.3K 0.6W	4
	Resistor 470R 0.6W	8
	Sector EOL	4
	Battery Link	1
	Battery Lead	1
	Capacitor 22uF 35V	4
	Instructions	1
	Keys fitted to the enclosure.	1 pair
	Battery supplied in separate package 12V 2.1Ah	2

Cable termination

Softskin (Fire Tuf)
CABLE TERMINATION

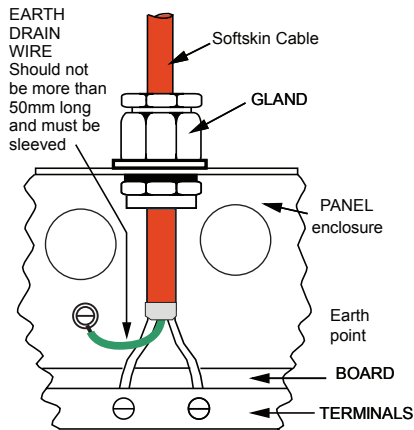

MICC
CABLE TERMINATION

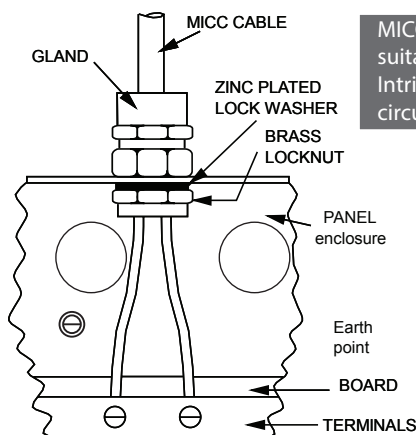

MICC cable is not suitable for wiring Intrinsically Safe circuits.

Mains supply

The mains supply cable must be a standard fire resisting type and should meet PH30 classification, such as any of the standard and enhanced loop cable. Requires a minimum conductor cross sectional area of 0.75mm².



Ensure that the mains supply cable enters the enclosure through a dedicated cable entry, located adjacent to the mains terminal block and that is also segregated from loop wiring.



These fire alarm system products are not designed to be powered from IT Power systems.

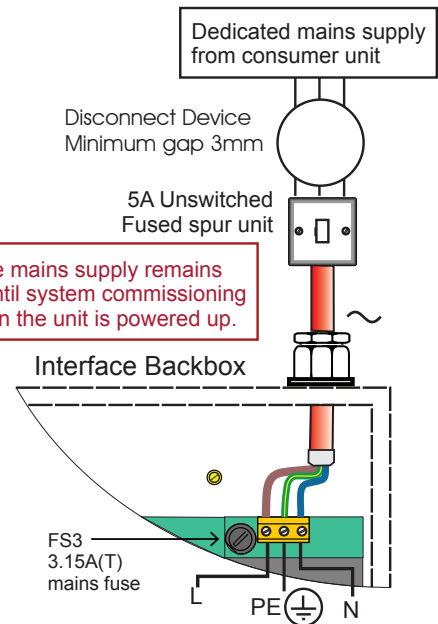

Ensure the mains supply remains isolated until system commissioning stage when the unit is powered up.

All mains powered equipment must be earthed. Mains supply to any fire alarm control and indicating equipment must be via an unswitched 5A fused spur unit. A disconnect device must be provided to disconnect both poles and must have a minimum gap of 3mm. The disconnect device should be available as part of the building installation and must be easily accessible after installation is complete.

Wiring test



DO NOT undertake high voltage insulation tests WITH THE CABLES CONNECTED to the Interface unit and external equipment. Such a test may damage the electronics circuitry in external equipment and in the Interface unit.

Intrinsically Safe and relay products

764744	Z969 Zener Barrier for IS detectors
764745	Z779 Zener Barrier to drive IS alarms
803271.EX	Rate-of-rise heat detector
803371.EX	Optical smoke detector
803374.EX	O2T-multisensor detector
805590	Detector Base
SOUNDER-EX	Banshee Excel IS28 MK6 ATEX sounder
VID-EX	IS Flashdome ATEX Approved VID
19104-52	Low voltage power relay

External wiring

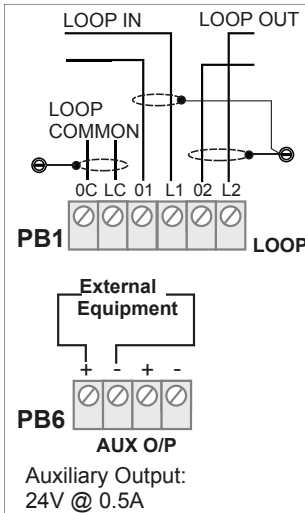

i It is possible to connect a number of LEDs in series (current is 1.5mA).

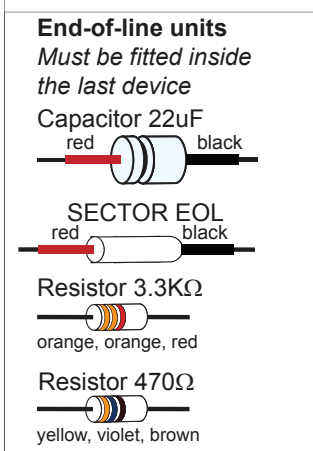
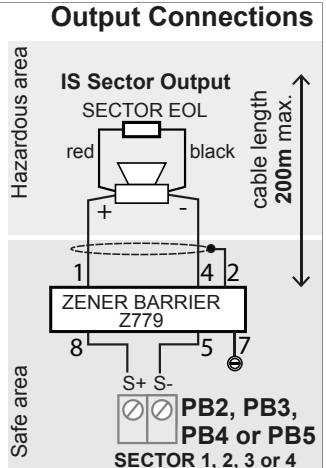
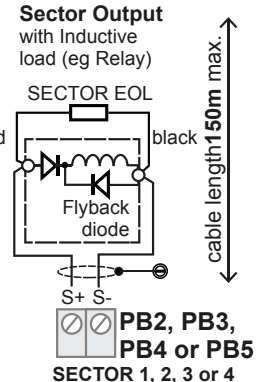
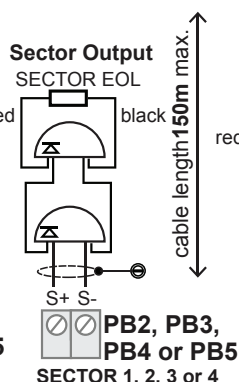
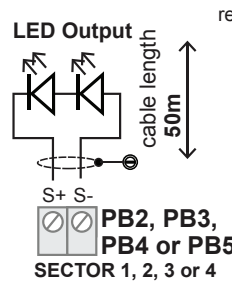

Input Connections

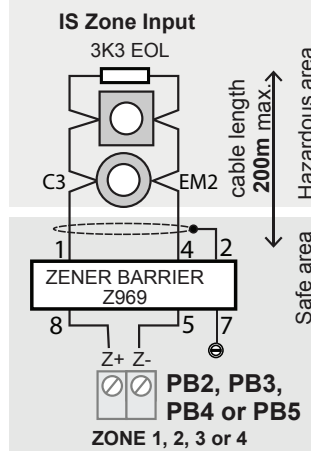
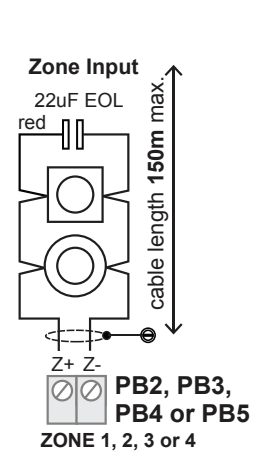

! To avoid damage to equipment always configure the interface inputs and outputs before connecting the external circuits.

i Normally closed contacts should be used for fail-safe applications.

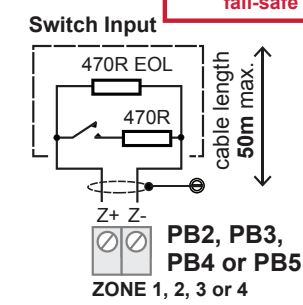

⊕ Connected to metal enclosure

! The Zener barriers and Power relays should be mounted on the DIN rail and apart using the metal screen provided inside the enclosure.

CE
2811

Gent by Honeywell (Novar Systems Limited)
Manufactured by: Honeywell Life Safety Systems,
140 Waterside Road, Hamilton Industrial Park,
Leicester, LE5 1TN, United Kingdom

15
DoP 120-CPR-2015 Product No. 78302-02NM

EN54-4: 1997 + A1:2002, A2:2006, EN54-17:2005, EN54-18:2005
78302-02NM (EN54-4-17 & 18)

Intended for use in fire detection and fire alarm systems in and around buildings

Refer to DOP 120-CPR-2015 for level or class of performance declared, for details see website www.smsfire.co.uk

♻️ At the end of their useful life, the packaging, product and batteries should be disposed of via a suitable recycling centre and in accordance with national or local legislation.

WEEE Directive:
At the end of their useful life, the packaging, product and batteries should be disposed of via a suitable recycling centre. Do not dispose of with your normal household waste. Do not burn.

Honeywell Gent reserves the right to revise this publication from time to time and make changes to the content hereof without obligation to notify any person of such revisions of changes.

	Hamilton Industrial Park, Waterside Road, Leicester LE5 1TN, UK.		Website: www.smsfire.co.uk
	Telephone: +44 (0) 116 246 2100	Tech. Support www.smstoolbox.co.uk	Fax (UK) +44 (0) 116 246 2016

Intrinsically Safe (IS) Application Information

Mains Powered Interface

(78302-02NM)



Intrinsically Safe (IS) system design

The intrinsically safe detection and alarm devices for use in hazardous area should be wired and tested by trained engineers familiar with the relevant code of practice, these are:

- BS EN 60079-14:2014 Explosive atmospheres. Electrical installations design, selection and erection
- BS5839-1 Fire detection and fire alarm systems for buildings. Code of practice for design, installation, commissioning and maintenance of systems in non-domestic premises

Zener Barriers

There are two types of Zener Barriers recommended for use with the Mains powered interface unit (78302-02) and these are:

- Z969 for wiring of IS Detectors (764744)
- Z779 for driving of IS Alarms (764745)

The Zener barrier recommended do not impose restrictions and permit monitoring of each IS circuit with an end of line component.

Loading of IS Circuit

There is a limit to the number of IS detectors and IS Alarm devices that can be connected to the respective Zener barrier.

It is also important to restrict the number of devices on IS circuits to ensure correct operation of the detection zone and alarm circuits and to ensure the circuits can be provided by the Mains powered interface unit.

Wiring IS circuits

Where more than one type of IS circuits go into hazardous area then each circuit must be connected to its own independent Zener barrier. An IS circuit may not be connected to other electrical circuit.

Cable used to wire IS circuits

The recommended cable for wiring IS circuits is the **FireTuf**, refer to the cable manufacturers data sheet for further information when using it for wiring Fire protection system.

The FireTuf FT120 Fire alarm cable 2 x 1.5mm² has typical electrical characteristic as shown below:

- Loop resistance of : 24 ohm/km
- Loop inductance of : 0.67 mH/km
- Capacitance core/core of : 82 nF/km
- Capacitance core/screen of : 144 nF/km
- and L / R ratio of : 28µH/ohms

How to fit a Zener Barrier on to the DIN rail in a Mains Powered Interface

Ensure the DIN Rail is able to accommodate Zener Barriers.

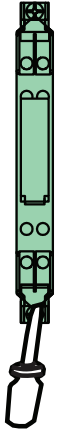

- 1** Carefully insert a terminal screwdriver to open out DIN rail fitment on the Zener Barrier. See markings on the Zener Barrier enclosure to identify exactly where the screwdriver is to be inserted.

- 2** Position the Zener Barrier with screwdriver engaged to the left of the start of the DIN rail.

- 3** Slide the Zener Barrier on to the DIN Rail to the right to a desired position.

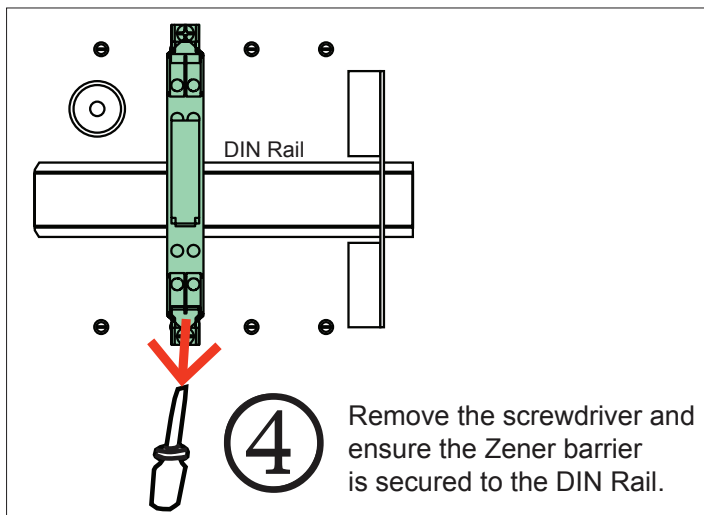
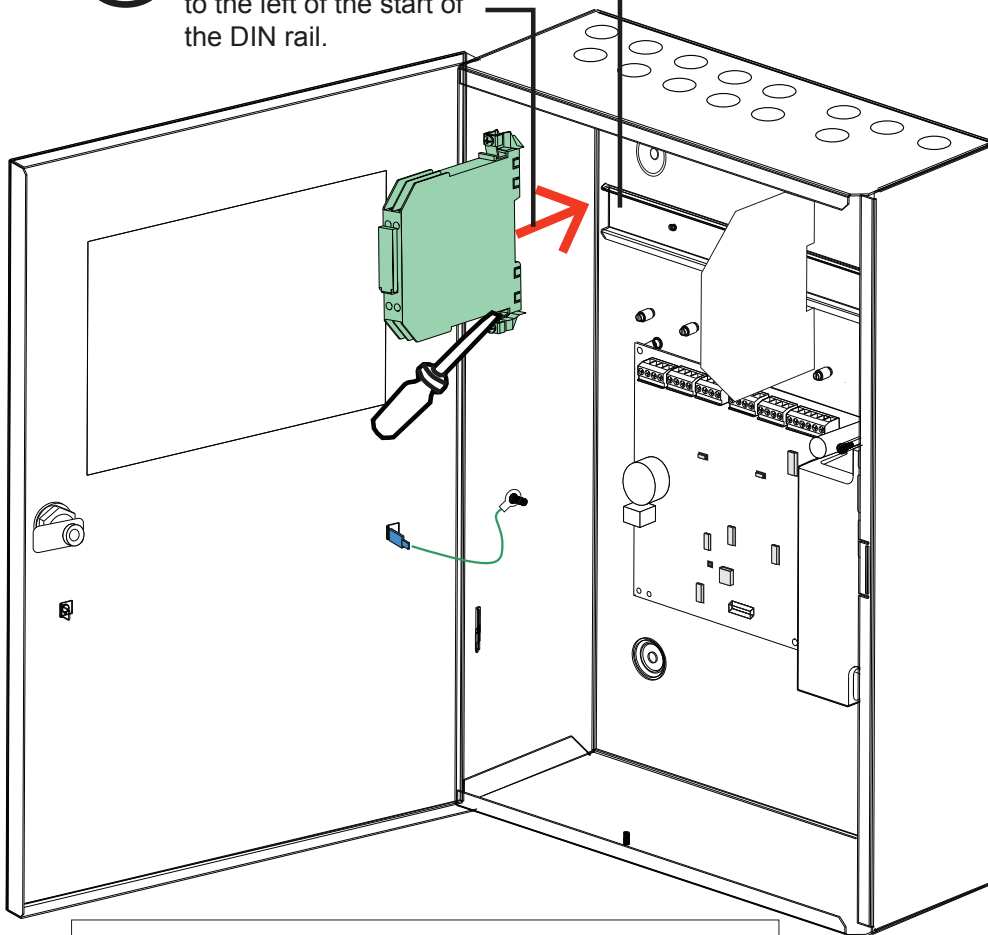

How to wire up an IS Zone circuit with IS detectors

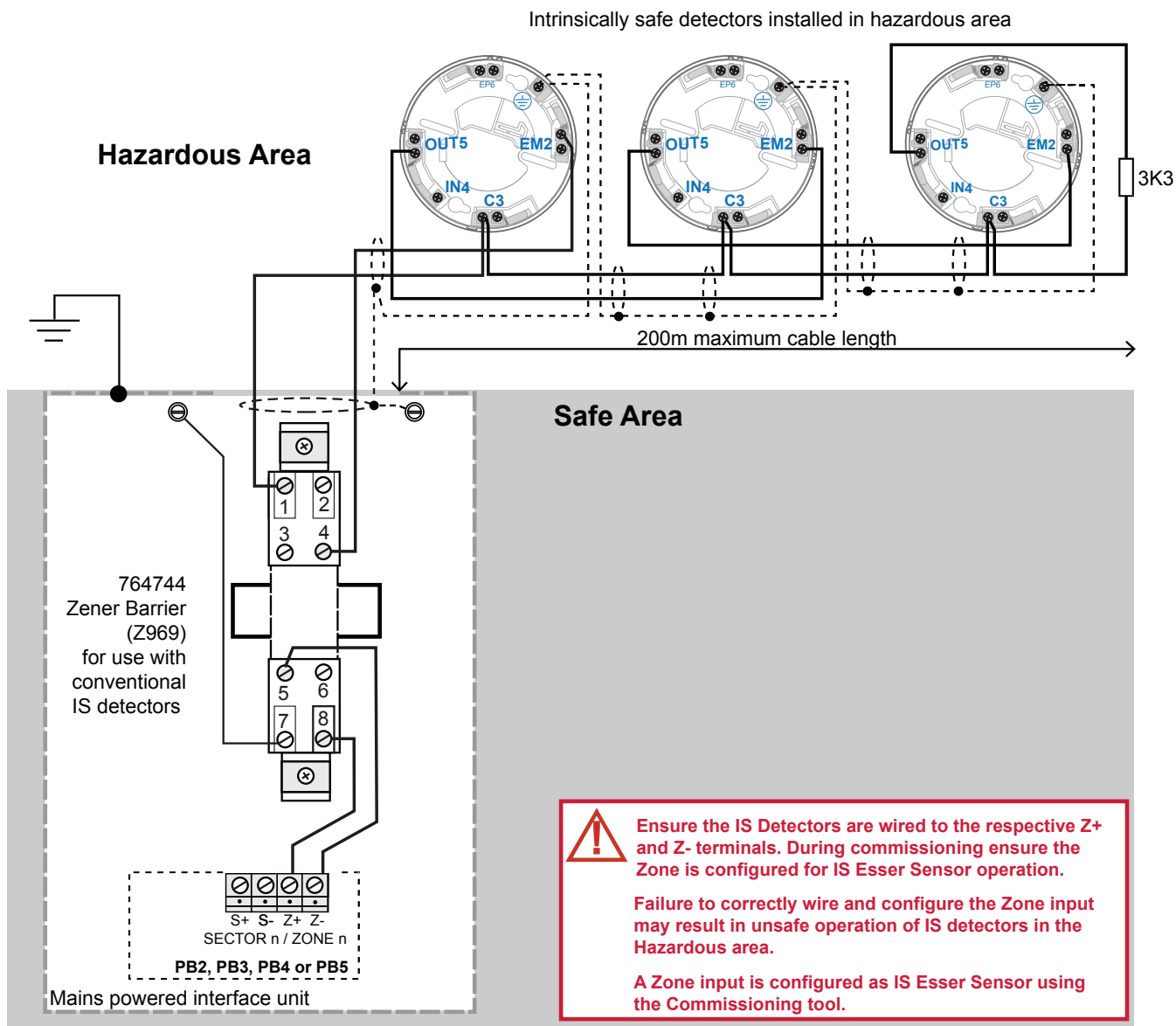

Recommended IS detection devices

- Rate-of-rise heat detector (803271.EX)
- Optical smoke detector (803371.EX)
- O2T-multisensor detector (803374.EX)
- Base (805590)
- a maximum of up to **15** IS detectors are allowed per circuit over a **200m** cable length using FireTuf, which is the approved cable for wiring of IS Detectors

For information on IS Detectors see Website Esser by Honeywell and serch for the above products and their data sheets and for information on 764744 (Z969) see “Zener Barriers” on page 7.

How to wire up an IS Sector circuit with an IS Sounder

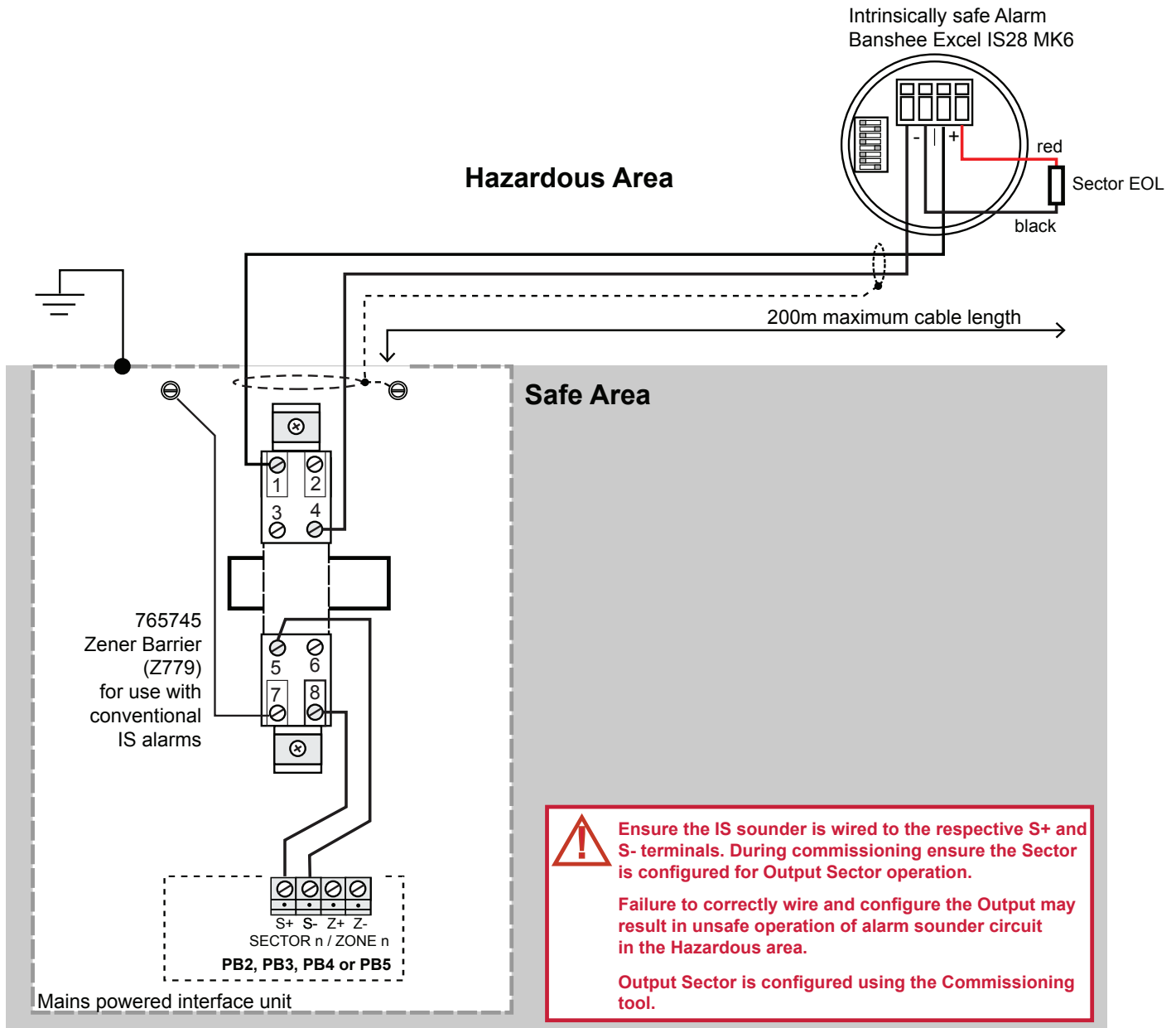

Recommended IS Alarm device

- SOUNDER-EX Banshee Excel IS28 MK6 ATEX sounder
- A maximum of up to **1** Banshee Excel IS28 Mk 6 is allowed per circuit over a **200m** cable length using **FireTuf**, which is the approved cable for wiring of IS Sounders.

For information on IS Sounder see the data sheet supplied with the product and for information on 764745 (Z779) see “Zener Barriers” on page 7.

How to wire up an IS Sector circuit with IS Beacons

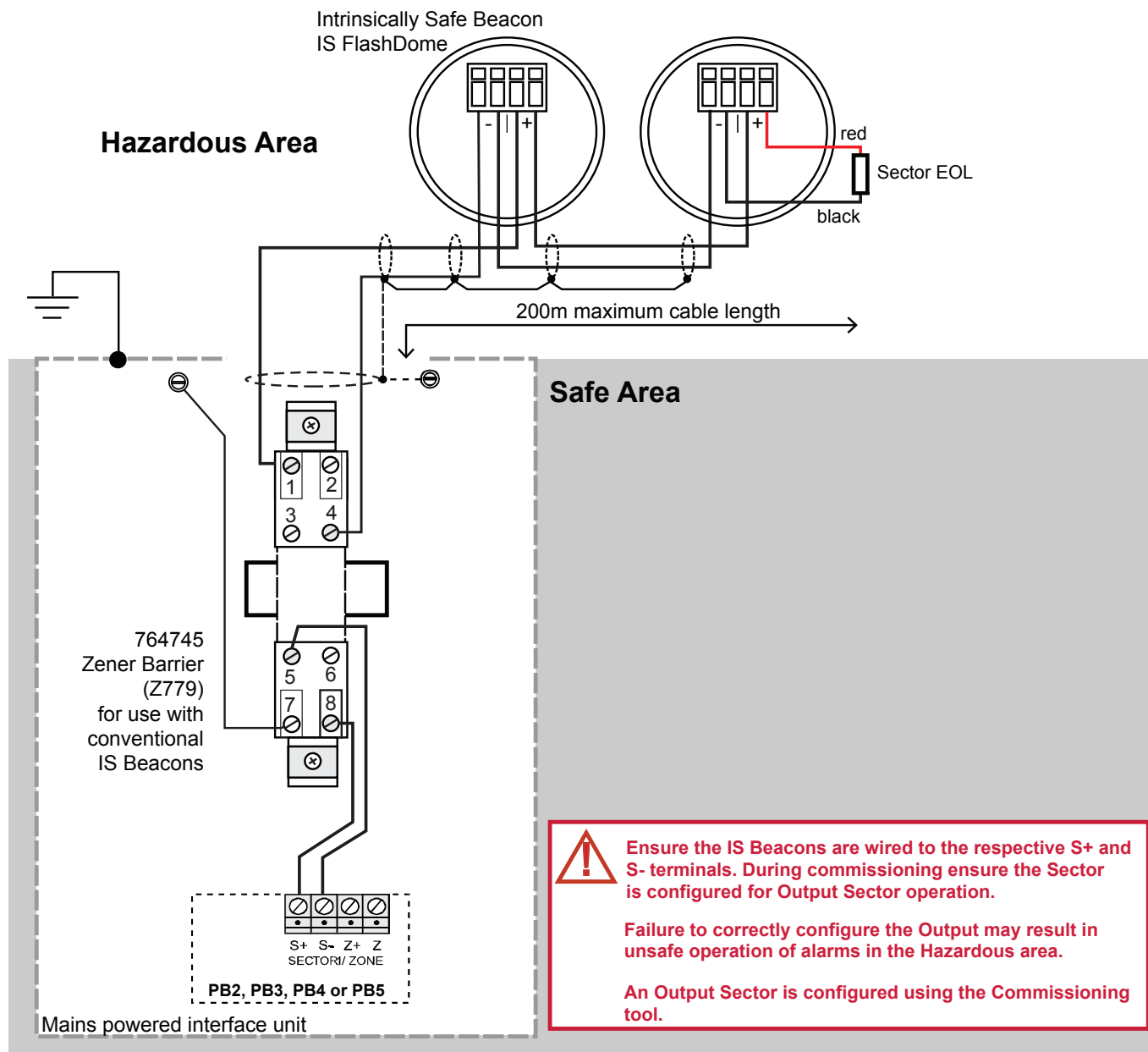

Recommended IS Beacon

- VID-EX IS Flashdome ATEX Approved VID
- A maximum of up to 2 IS Banshee IS FlashDome are allowed per circuit over a 200m cable length using FireTuf, which is the approved cable for wiring of IS Beacons.

For information on IS Beacon see the data sheet supplied with the product and for information on 764745 (Z779) see “Zener Barriers” on page 7.

Specification for IS Detectors



These automatic fire detectors and detector base may not be installed in areas with atmosphere containing benzene, acetic acid or esters as the ABS plastic of the housing is not resistant to these chemicals.

General detector data according to ATEX

Maximum Input voltage (Ui)	: 21 V DC
Maximum Input current (Ii)	: 252 mA
Maximum Output current (Io)	: 10 mA
Maximum internal Capacity (Ci)	: 1 nF
Ambient temperature (Ta)	: - 20 °C to + 70 °C (Ambient temperature according to ATEX)
Examination Certificate No.	: TÜV 09 ATEX 554910
Category	: II 2G (with safety barrier Part No. 764744)
Ex-protection	: Ex ib IIC T4

Detector identification according to ATEX

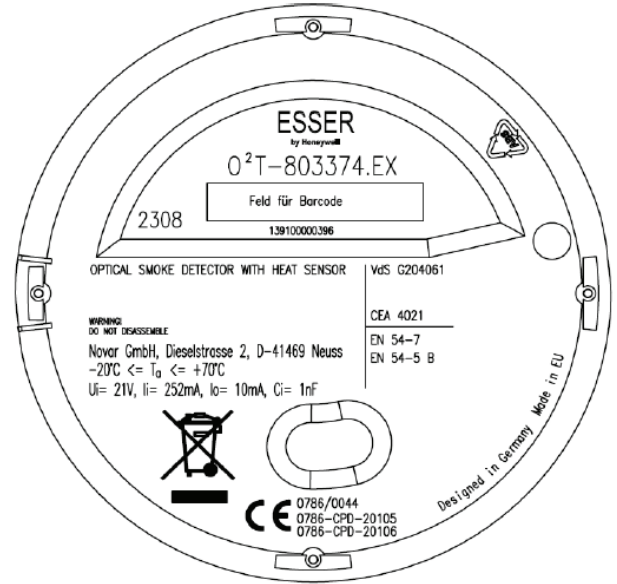
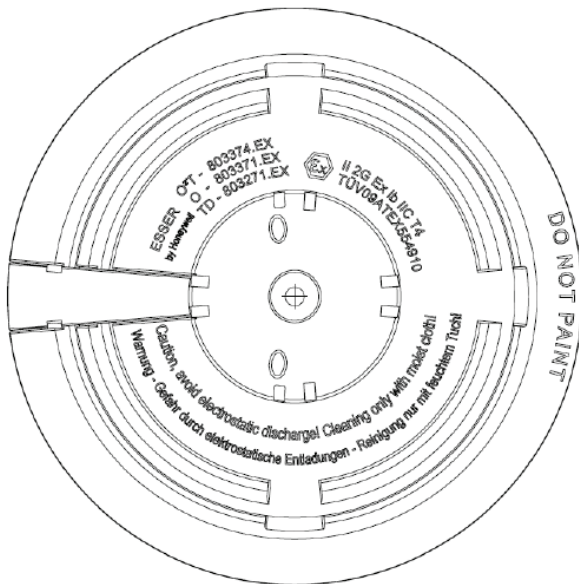

General Specifications

Operating voltage	: 8 V DC to 42 V DC (21V DC for ATEX)	IP rating	: IP 43 (with base + option)
Type of sensor	Heat and Smoke*	Housing	: ABS
Air velocity range	: 0 to 5.000 ft/min.	Colour	: white (similar to RAL 9010)
Quiescent current for		Weight	: approx. 110 g
Rate-of-rise heat detector	: @ 19 V DC is 40 µA 803271.EX *1	Dimensions (with base)	: Ø 117 mm, H = 62 mm
Optical smoke detector	: @ 19 V DC is 50 µA 803371.EX *2		
O ² T-multisensor detector	: @ 19 V DC is 60 µA 803374.EX *2		
Temperature, storage	: -25 °C to +75 °C		
Ambient humidity	: ≤ 95% relative humidity non- condensing		

Zener Barriers

Specification for Z 969 Zener Barrier

Examination certificate No. : BAS 01 ATEX 7005

Operating voltage : $U_N = 19,24 \text{ V}$

Complete internal resistance : $R_i = 86,13 \Omega$

Maximum Voltage Ex (i) circuit : $U_o = 19,24 \text{ V}$

Maximum short circuit current Ex (i) circuit : $I_o = 224 \text{ mA}$

Maximum load Ex (i) circuit : $P_o = 1.08 \text{ W}$

Maximum capacity Ex (i) circuit : $II \text{ C} / C_o = 250 \text{ nF}$

Maximum inductivity Ex (i) circuit : $II \text{ C} / L_o = 650 \mu\text{H}$

Maximum voltage non- Ex (i) circuit : $U_m = 250 \text{ V}$

Fuse : 80 mA

Degree of protection : IP 20 in accordance to IEC 144

Ambient temperature : $- 20 \text{ }^\circ\text{C}$ to $+ 60 \text{ }^\circ\text{C}$

Storage temperature : $- 40 \text{ }^\circ\text{C}$ to $+ 80 \text{ }^\circ\text{C}$

Weight : approx. 150 g

Dimensions (w x h x d) : 12.5 x 110 x 115 (mm)

Zener Barrier 764744 (Z969) internal wiring

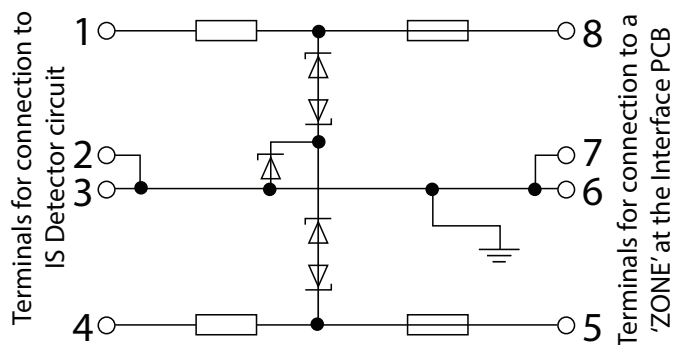

Specification for Z 779 Zener Barrier

For full information refer to Pepperl+Fuchs data sheet

Examination certificate No. : BAS 01 ATEX 7005

Working voltage : 26.5 V at 10 μA

Series resistance maximum : 327 Ω

Maximum Voltage Ex (i) circuit : $U_o = 28 \text{ V}$

Maximum short circuit current Ex (i) circuit : $I_o = 93 \text{ mA}$

Maximum load Ex (i) circuit : $P_o = 0.65 \text{ W}$

Maximum capacity Ex (i) circuit : $II \text{ C} / C_o = \text{ nF}$

Maximum inductivity Ex (i) circuit : $II \text{ C} / L_o = \text{ mH}$

Maximum safe voltage non - Ex (i) circuit : $U_m = 250 \text{ V}$

Fuse : 50 mA

Degree of protection : IP 20

Ambient temperature : $- 20 \text{ }^\circ\text{C}$ to $+ 60 \text{ }^\circ\text{C}$

Storage temperature : $- 25 \text{ }^\circ\text{C}$ to $+ 70 \text{ }^\circ\text{C}$

Relative humidity : maximum 75 %, without condensation

Mount on a 35 mm DIN mounting rail

Weight : approx. 150 g

Dimensions (w x h x d) : 12.5 x 110 x 115 (mm)

Zener Barrier 764745 (Z779) internal wiring

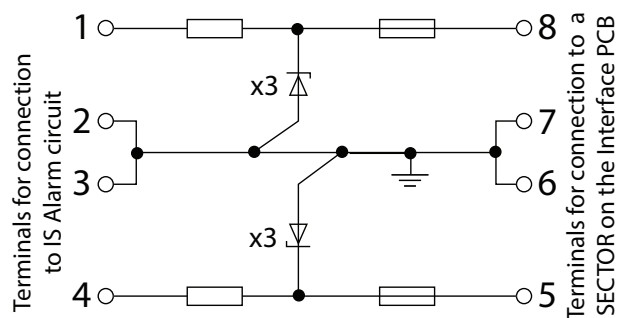

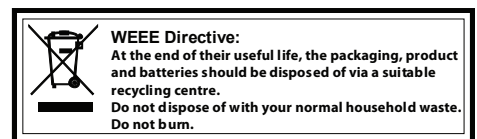
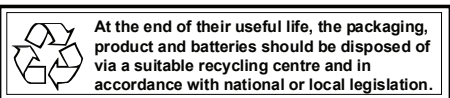

Honeywell Gent reserves the right to revise this publication from time to time and make changes to the content hereof without obligation to notify any person of such revisions of changes.

	Hamilton Industrial Park, Waterside Road, Leicester LE5 1TN, UK.		Website: www.smsfire.co.uk
	Telephone: +44 (0) 116 246 2100	Tech. Support www.smstoolbox.co.uk	Fax (UK) +44 (0) 116 246 2016