

# 7100X and 7100XA FAAST Fire Alarm Aspiration Sensing Technology®

3825 Ohio Avenue, St. Charles, Illinois 60174  
1.800.SENSOR2; Fax: 630.377.6495  
www.systemsensor.com

**SPECIFICATIONS**

**Electrical Characteristics**

External Supply Voltage	18 – 30 VDC
Remote Reset Time	External monitor must be pulled low for a minimum of 100 msec
Power Reset	1 sec
Relay Contact Ratings	3.0A @ 30VDC, 0.5A @125VAC

**Environmental Ratings**

Operating Temperature	32°F (0°C) to 100°F (38°C) – Factory tested to 131°F (55°C)
Sampled Air Temperature	-4°F (-20°C) to 140°F (60°C)
Humidity	10 to 95% non-condensing
IP Rating	IP30
Hazardous Environments	This equipment is suitable for use in Class I, Division 2, Groups A, B, C and D, or non-hazardous locations only.

The purpose of this document is to provide practical information for mounting and connecting to FAAST XS. For full product information, which includes installation guidelines, instructions for safe use, and warranty and safety information, refer to the FAAST XS Comprehensive User Guide available at [systemsensor.com/7100Xuserguide](http://systemsensor.com/7100Xuserguide) or by scanning the QR code.

**ITEMS INCLUDED WITH UNIT**

- FAAST XS (7100X or 7100XA) device
- Mounting bracket and hardware
- Installation and Maintenance Instructions
- USB interface cable
- PipeIQ® software, comprehensive manual, and other helpful documents are available at [systemsensor.com/faast](http://systemsensor.com/faast)



**CONNECTING TO FAAST XS**

FAAST XS requires a valid configuration from PipeIQ in order to initialize. The device must be connected to a PC running PipeIQ with either the USB port, or the Ethernet port located inside the wiring cabinet.

NOTE: Class 1, Div 2 -- RJ45 and USB Connectors are for maintenance use only and shall not be used while in a Hazardous Location unless power has been removed or the area is known to be non-hazardous.

**CONNECTING TO FAAST XS VIA USB**

NOTE: In order to connect your computer to the FAAST XS using a USB connection, a USB driver must first be installed. The driver installation occurs during the installation of PipeIQ version 2.2 or later. Once the driver is installed, connect to the device using the following steps.

1. Launch PipeIQ. (Download from [www.systemsensor.com/faast](http://www.systemsensor.com/faast).)
2. Create a new project and select FAAST XS device, or open an existing project
3. Expand the tree view in the left side navigation pane to reveal the device
4. Right click on the device and select 'Connect Device'
5. Select USB, The USB combo box should already be populated with FAAST XS (COM Port Number).
6. Select 'Admin' and enter the password – the default password is 'password' – then click 'Connect'.

**CONNECTING TO FAAST XS VIA ETHERNET**

Default Device	IP Configuration
IP Address:	192.168.1.10
Subnet Mask:	255.255.255.0
Default Gateway:	192.168.1.1
Primary DNS:	0.0.0.0
Secondary DNS:	0.0.0.0

**CONFIGURE YOUR PC**

Your PC will need to be sitting on the same local area network as the FAAST XS device in order to establish communication. Change your PC's IP address to 192.168.1.15 by:

1. Accessing your network setting in your PC's control panel

2. Open 'Local Area Connection' settings and select 'Properties'
3. Select 'Internet Protocol Version 4 (TCP/IPv4) and then select 'Properties'
4. Select 'Use the following IP address and enter 192.168.1.15. If the subnet mask does not automatically populate, enter 255.255.255.0 into the subnet mask field.
5. Click OK and close out of the network menus.

**Important Note:** Before changing your PC's IP address, be sure to take note of whether your IP is currently dynamically set, or is a static IP address. If your PC is assigned a static IP address, make note of all IP address and settings so that you can change back to the proper settings after the FAAST has been configured.

**CONNECT USING PIPEIQ**

1. Launch PipeIQ. (Download from [systemsensor.com/faast](http://systemsensor.com/faast))
2. Create and save a new project, or open an existing project
3. Expand the tree view in the left side navigation pane to reveal the device
4. Right click on the device and select 'Connect Device'
5. Select Host/IP and type in the device's IP address - default is 192.168.1.10
6. Select 'Admin' and enter the password – the default password is 'password' – then click 'Connect'.
7. Upon connection, a green dot will appear on the device icon in the navigation tree.

**INSTALLATION**

This equipment must be installed in accordance with all local and national codes and regulations.

**PIPE INSTALLATION**

The pipe layout is designed using the PipeIQ software package. Refer to the Comprehensive Instruction Manual to design the pipe network. All pipe must be installed in accordance with local and national codes and regulations. The pipe network should be complete before proceeding with the physical and electrical system installation.

**PHYSICAL UNIT INSTALLATION**



Make sure that there are no pipes or electrical wires within the wall before drilling any mounting holes

**SECURING THE MOUNTING BRACKET**

The typical mounting location for the FAAST XS unit is on the wall. The unit is mounted to the wall using the enclosed mounting bracket. Figure 1 shows the wall mounting bracket. For easier access to the FAAST XS unit, it is preferred to position the mounting bracket in an easily accessible location.

1. Place the mounting bracket on the wall in the desired location and use it as a template to locate the necessary mounting holes.
2. Mark the hole locations and remove the bracket. It is recommended to secure the bracket using both mounting holes.

- Using a drill and the proper size bit for your mounting hardware, drill the necessary holes.
- Use appropriate fasteners to accommodate the mounting surface and FAAST XS device weight.
- Secure the bracket to the wall.

### MOUNTING THE DETECTOR TO THE BRACKET

Once the mounting bracket is attached, the unit is ready to be secured onto the bracket. Perform the following procedure to mount the unit.

- Before installing the unit onto the bracket, remove the appropriate conduit caps from the top or left side of the unit to match the orientation of the wiring.
- Align the unit with the three mounting clips and the mounting stud on the left side. Locate the conduit openings around the wiring access door.
- Push the unit down onto the mounting clips and secure it with the supplied

**FIGURE 1: WALL MOUNTING BRACKET**

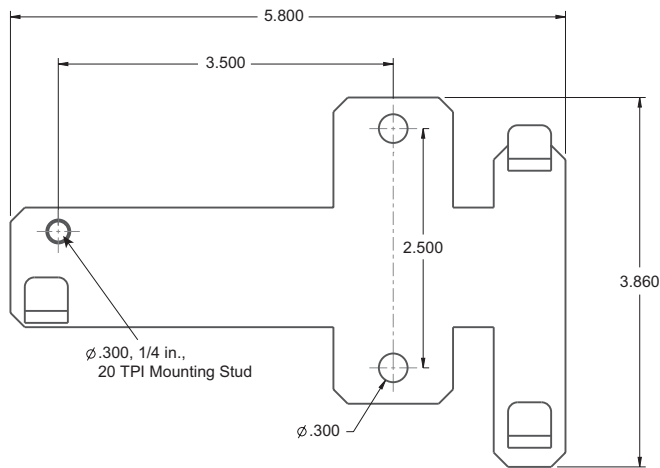

ASP127-00

**FIGURE 2: MOUNTING SLOTS FOR MOUNTING STUDS**

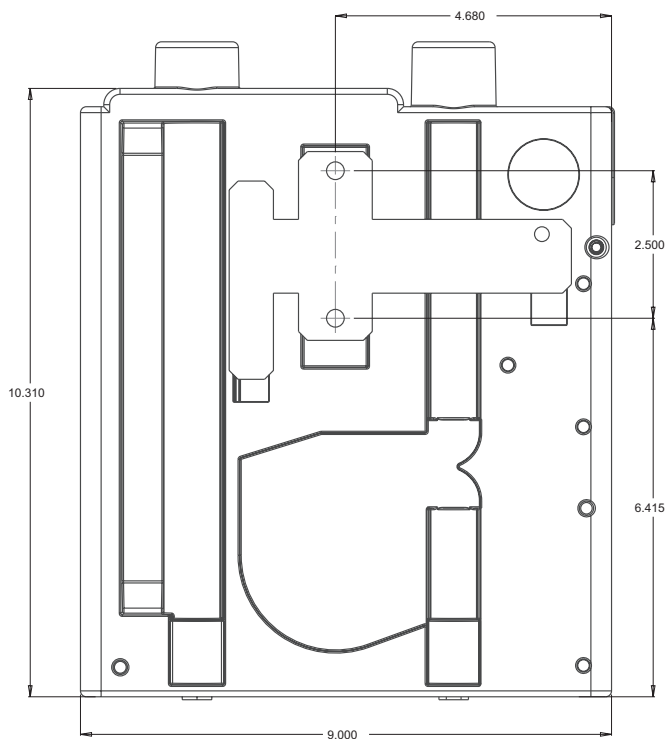

ASP126-00

washer and nut on the mounting stud protruding through the mounting slot shown in Figure 1.

### CONNECTING THE AIR SAMPLING PIPE

#### ATTENTION

Detailed pipe network information and best practices can be found in the Pipe Installation Guide, available for download at [systemsensor.com/faast](http://systemsensor.com/faast)

The input and output ports are designed to accept nominal one inch pipe (25mm). The input and output ports are tapered to provide fast, easy, pushfit connection of the sampling pipe to the unit. Perform the following procedure to connect the air sampling pipe to the unit.

- Square off and de-burr the end of the sampling pipe. Ensure that the pipe is free from any particles that might interfere with the pipe connection.
- Remove the input plug from the input port being used (either the top or bottom of the unit).
- Inset the air sampling pipe into the port, ensuring a snug fit. DO NOT glue these pipes.

### EXHAUST PIPE

The device should always be exhausted into the space that it is monitoring. There are some circumstances where it may be necessary to connect a pipe to the exhaust port to divert the exhaust away from the location of the unit. Adding as little as 2ft of exhaust pipe also acts as a muffler for the fan – ensuring quieter operation. Perform the following procedure to connect the exhaust pipe to the unit.

- Square off and de-burr the end of the exhaust pipe. Ensure that the pipe is free from any particles that might interfere with the pipe connection.
- Remove the plug from the exhaust port being used (either the top or bottom of the unit).
- Inset the air exhaust pipe into the port, ensuring a snug fit. DO NOT glue these pipes.

### WIRING

#### WARNING

Before working on the FAAST XS system, notify all required authorities that the system will be temporarily out of service. Make sure all power is removed from the system before opening the unit. All wiring must be in accordance with local codes.

### POWER CABLES

Use the power ratings of the unit and any other connected products to determine the required wire sizes for each connection.

### CONDUIT USAGE

If electrical conduit has been used for system wiring, terminate the conduits at the cable entry ports on the top of the unit, using the appropriate conduit connectors.

- Run all wiring, both power and alarm, through the conduit and into the left side of the unit enclosure.
- Attach the appropriate wires to the supplied Euro connectors. Follow appropriate local codes and electrical standards for all cabling.
- Plug the appropriate connector into the mating connector on the unit. Refer to Table 1.

**FIGURE 3. POWER AND ALARM CONNECTION BLOCK**

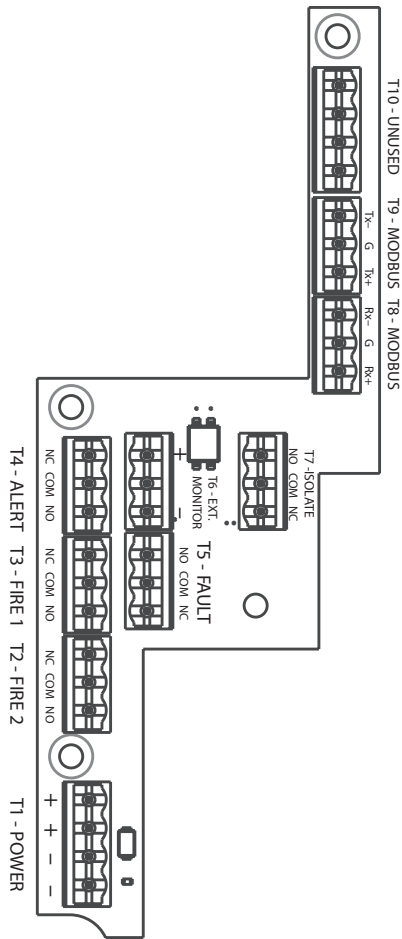

ASP128-00

**FIGURE 4. FACP WIRING DIAGRAM**

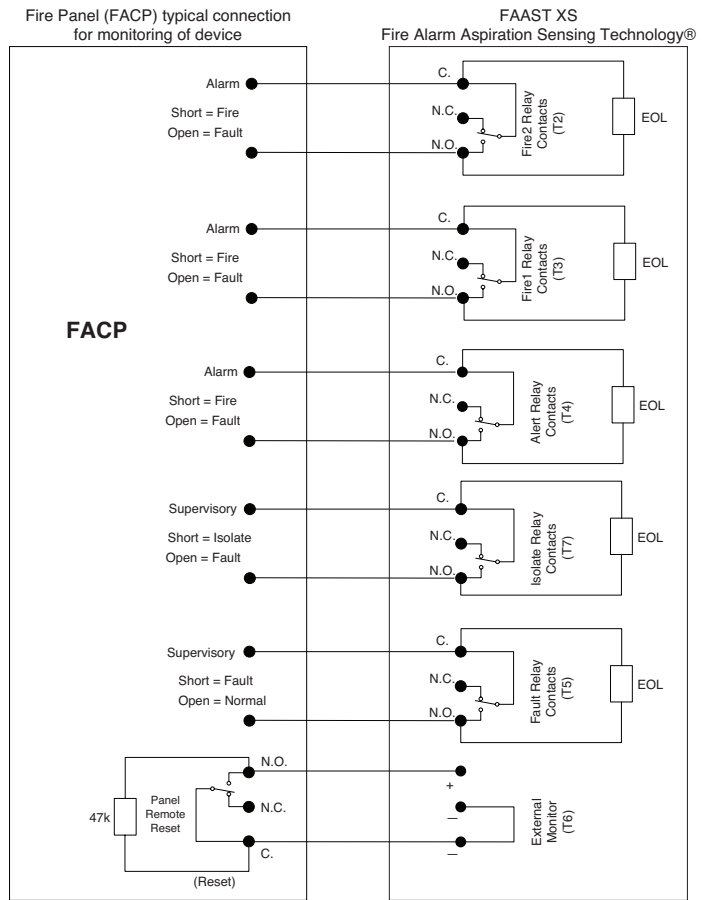

ASP18-23

**TABLE 1. TERMINAL DESIGNATIONS**

TERMINAL BLOCK	DESCRIPTION
T1	External Power – Powers Aspirating Smoke Detector
T2	Fire2 Relay – Maintains state on loss of power
T3	Fire1 Relay – Maintains state on loss of power
T4	Alert Relay – Maintains state on loss of power
T5	Fault Relay – Resets on loss of power
T6	External Monitor – Maintains state on loss of power
T7	Isolate Relay – Maintains state on loss of power
T8	RS 485 Rx Rx and Tx can be wired in a half duplex configuration
T9	RS 485 Tx Rx and Tx can be wired in a half duplex configuration
T10	Unused

**SYSTEM WIRING**

Refer to Table 1 for the field wiring terminal descriptions of the unit. Refer to Figure 4 for a typical connection for monitoring the FAAST XS system at a Fire Alarm Control Panel (FACP).

**SYSTEM POWERING**

The following procedure describes how to initially power up the FAAST XS system.

1. Unplug the unit’s power connector to the unit before turning on the power.
2. Turn on the power.
3. Check the voltage at the connector. Make sure it is within the required voltage range.
4. If wiring is not connected to the external monitor terminal, install a 47kΩ resistor (provided with the unit) into the terminal block and fit it into the T6 terminal.
5. If the voltage is within the proper range, reconnect the power connector to the unit.
6. Connect a computer, with PipeIQ installed, to the unit using either the USB connection, or the Ethernet port located inside the wiring cabinet. (See the ‘Connecting to FAAST XS’ for detailed connection instructions.)
7. Use the PipeIQ software to set up the unit configuration required for the particular application.
8. The PC may now be disconnected unless a permanent networked connection is desired. Note: The USB and RJ45 Connectors must be removed in hazardous locations.
9. Verify the system fan starts up and air begins to flow out of the exhaust port. The user interface will provide the device status.
10. The device will establish an airflow baseline during the first five minutes of operation. After five minutes, the airflow level display will provide the true measured airflow status. The device will give visual indication of the baselining period on the LCD screen.

---

#### LASER SAFETY INFORMATION

This aspiration detector does not produce any hazardous laser radiation and is certified as a Class 1 laser product under the U.S. Department of Health and Human Services (DHHS) Radiation Performance Standard according to the Radiation Control for Health and Safety Act of 1968. Any radiation emitted inside the smoke detector is completely within the protective housings and external covers.

The laser beam cannot escape from the detector during any phase of operation. The Center of Devices and Radiological Health (CDRH) of the U. S. Food and Drug Administration implemented regulations for laser products on August 2, 1976. These regulations apply to laser products manufactured after August 1, 1976. Compliance is mandatory for products marketed in the United States.

---

#### WARRANTY

System Sensor warrants its enclosed smoke detector to be free from defects in materials and workmanship under normal use and service for a period of three years from date of manufacture. System Sensor makes no other express warranty for this smoke detector. No agent, representative, dealer, or employee of the Company has the authority to increase or alter the obligations or limitations of this Warranty. The Company's obligation of this Warranty shall be limited to the repair or replacement of any part of the smoke detector which is found to be defective in materials or workmanship under normal use and service during the three year period commencing with the date of manufacture. After phoning System Sensor's toll free number 800-SENSOR2 (736-7672) for a Return Authorization number, send defective units postage prepaid to: Honeywell, 12220 Rojas

Drive, Suite 700, El Paso TX 79936, USA. Please include a note describing the malfunction and suspected cause of failure. The Company shall not be obligated to repair or replace units which are found to be defective because of damage, unreasonable use, modifications, or alterations occurring after the date of manufacture. In no case shall the Company be liable for any consequential or incidental damages for breach of this or any other warranty, expressed or implied whatsoever, even if the loss or damage is caused by the Company's negligence or fault. Some states do not allow the exclusion or limitation of incidental or consequential damages, so the above limitation or exclusion may not apply to you. This Warranty gives you specific legal rights, and you may also have other rights which vary from state to state.

---

#### GENERAL WARNINGS

The use of all FAAST products (configuration, design, use and maintenance) must be performed in accordance with the technical documentation, General Terms and Conditions and local regulations and/or directives for design, installation and maintenance of fire alarm systems. Product Manuals, User Guides, White Papers, CAD Drawings, Datasheets, Engineering specifications are available from [www.systemsensor.com/faast](http://www.systemsensor.com/faast). The performance of this system is dependent upon the pipe network. Any extensions or modifications to the designed installation may cause improper operation. The operational effects of such changes shall be verified. A design tool is available from the System Sensor webpage.

Class 1, Div 2 - RJ45 Connector is for maintenance use only and shall not be used while in a Hazardous Location unless power has been removed or the area is known to be non-hazardous. These units are tested and regulatory approved to allow the pipe networks to be installed in corrosive or hostile environments. The aspiration unit itself should operate in a controlled environment as per the specifications listed in the manual. The detector unit is not suitable to be installed in hostile environments.

---

#### FCC STATEMENT

This device complies with part 15 of the FCC Rules. Operation is subject to the following two conditions: (1) This device may not cause harmful interference, and (2) this device must accept any interference received, including interference that may cause undesired operation.

NOTE: This equipment has been tested and found to comply with the limits for a Class A digital device, pursuant to Part 15 of the FCC Rules. These limits are designed to provide reasonable protection against harmful interference in a residential installation. This equipment generates, uses and can radiate radio frequency energy and, if not installed and used in accordance with the instructions, may cause harmful interference to radio communications. However, there is no guarantee that interference will not occur in a particular installation. If this equipment does cause harmful interference to radio or television reception, which can be determined by turning the equipment off and on, the user is encouraged to try to correct the interference by one or more of the following measures:

- Reorient or relocate the receiving antenna.
- Increase the separation between the equipment and receiver.
- Connect the equipment into an outlet on a circuit different from that to which the receiver is connected.
- Consult the dealer or an experienced radio/TV technician for help.

This Class A digital apparatus complies with Canadian ICES-003.